

*...moving fluids positively*



*...the worldover*



Mr. Ram Ratan Gupta  
(04.02.1918 - 14.02.1980)  
Founder  
**Roto Pumps**

## A genius ahead of his times

Mr. Gupta created history in 1968 by inventing a unique manufacturing process for machining the intricate profile rotor, which is the heart of progressive cavity pump. This technological innovation gave birth to Roto Pumps...

Mr. Gupta strongly believed in "in-house" development of products and manufacturing technology as opposed to importing technology. This philosophy translated into continuous investment in Research and Development as well as in manufacturing infrastructure, enabling Roto Pumps to produce quality products at a competitive cost.

## Message from the Chairman

Ours is the journey of an enterprise, which pioneered manufacture of progressive cavity pumps in India in the late 70's to a global player who is now counted amongst the top ten.

Since our inception, we have not only made continuous investments in product development and built a strong manufacturing infrastructure but also focused on developing skills in application engineering, vital to ensure superior performance and customer satisfaction.

The last decade saw Roto Pumps strengthening its overseas presence by setting up regional offices and warehousing facilities in Australia and United Kingdom and additionally, expanding distribution network in other markets.

Our continuous focus on technological upgradation would enable us to continue to offer state-of-the-art products and services with a competitive edge.

Harish Chandra Gupta  
Chairman & Managing Director





## Infrastructure

Roto Pumps has strong roots in manufacturing engineering and has over the years been able to develop efficient manufacturing processes both in the field of metal cutting and rubber processing. Spread over a combined factory area of 20,000 sq. meters, these units are equipped with sophisticated machine tools like CNC and other SPMs. These are also geared up with modern testing facilities including water and oil test bed with sophisticated data acquisition systems. The continuous investments in, in-house manufacturing facilities for critical components ensure 100% control over quality and customer satisfaction. Roto Pumps manufacturing units are certified for conformance with the ISO 9001-2008 quality surveillance systems, ISO 14001 and OHSAS 18001 (Occupation, Health, Safety & Environment) certifications.



Roto's Manufacturing Plant



## Research and Development

Roto Pumps Research and Development facility is the concrete realization of its philosophy of providing cost effective fluid engineering solutions. It translates concepts into prototypes and prototypes into final product. Our Research & Development team was also instrumental in helping the company to get its product accredited to ATEX certification.



This facility is equipped with state-of-the-art testing equipment, a captive machine shop and design centre. The design centre is equipped with 3D designing software such as solid works and also deploys advanced software for flow analysis, mechanical strength and cost optimization. Staffed with highly qualified and experienced professionals, the Roto Pumps R&D centre is playing a critical role in helping the company maintaining its leadership by continuously upgrading the technology as well as expanding the product range.

*We strive to be an excellent place to work and to empower our teams to achieve great results for our customers.*

Research and Development Centre at Noida







## Product information

As a positive displacement pump manufacturer, Roto Pumps continuously endeavours to increase its product basket to cater to a wider spectrum of industries and applications.

Our product line comprises of Progressive Cavity Pumps and Twin Screw Pumps to meet most varied pumping requirements.

While Progressive Cavity Pumps have applications in fluid metering and pumping of highly viscous, abrasive or sheer sensitive materials, the Twin Screw Pumps are used for clean, lubricating, non-lubricating as well as aggressive liquids.







## Roto Extra Value Advantage



Zero Leakage @ low torque

### Optimised Rotor Stator Geometry

- Improved Rotor - Stator geometry minimises wear due to lower rubbing velocities as compared to conventional geometry, particularly useful in abrasive applications
- Lower starting torque and effective sealing line (Zero Leakage) improves volumetric efficiency
- Resulting in reduced power consumption and extended service life

### Improved Pump Housing

- A sloped housing design reduces entry losses
- Facilitates easy drainage
- Its flexible housing orientation allows the suction port to be rotated in steps of 90° to suit any installation

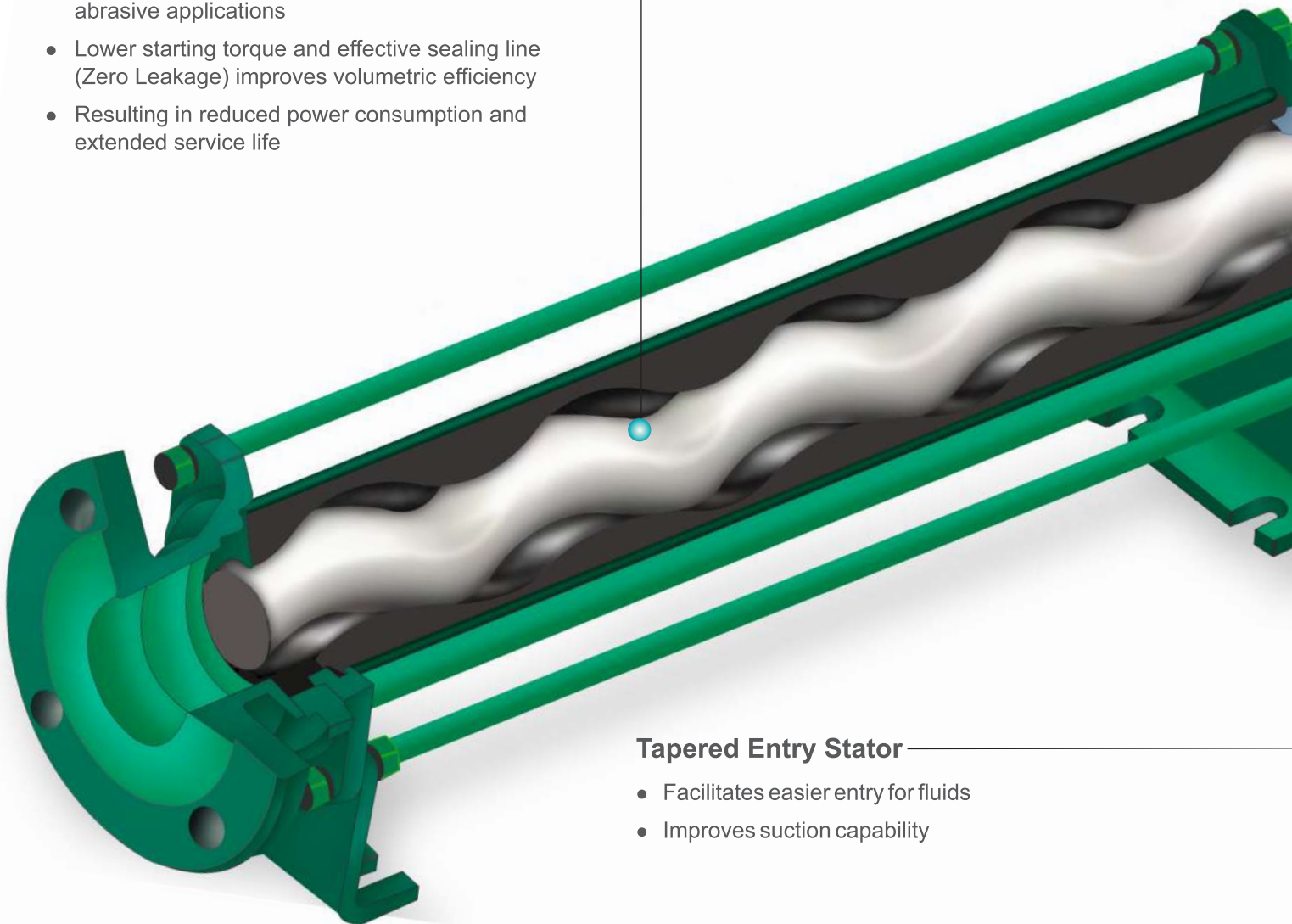

### Tapered Entry Stator

- Facilitates easier entry for fluids
- Improves suction capability

### Close Coupled

- Motor lantern designed to accommodate various construction of drives reduces the overall length and leads to ease of maintenance

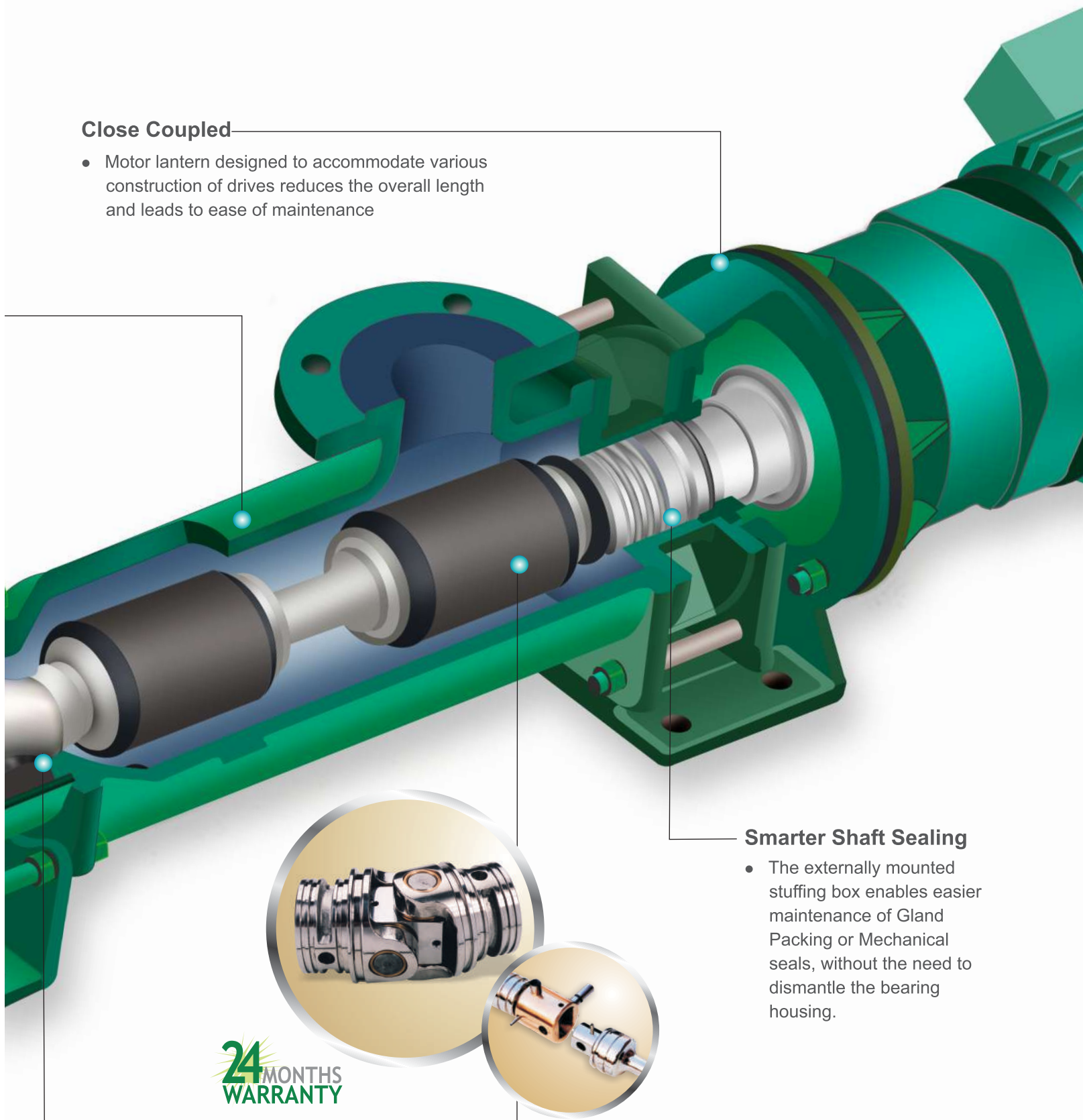

### Smarter Shaft Sealing

- The externally mounted stuffing box enables easier maintenance of Gland Packing or Mechanical seals, without the need to dismantle the bearing housing.

**24** MONTHS  
WARRANTY

### Cardan Universal Joint

- The Cardan type universal joint used in this pump is acknowledged to be far superior to the conventional gear joint, or single pin & bush joint which is subjected to extreme concentrated loads, resulting in high wear rates
- The Cardan type of UJ joint employs two sets of perpendicular pins, each providing freedom of angular movement, which facilitates smoother transmission of angular loads
- The Cardan type UJ joint is also designed to withstand high axial forces which are dominant in Progressive Cavity Pumps

## Progressive Cavity Pumps Range



### **Industrial RD/ RM series**

Capacities 250 M<sup>3</sup>/hr  
Pressures upto 48 Bar

These heavy duty pumps are designed for continuous or intermittent duty and are suitable to perform efficiently even for the most difficult fluid handling applications in waste water, chemical and food industries. These pumps are available in bare shaft and close coupled configurations. 6 and 8 stage pumps are also available in select sizes.



### **Extra Large Capacity RL series**

Capacities upto 420 M<sup>3</sup>/hr  
Pressures upto 6 Bar

These Heavy Duty cost effective pumps use the extended Rotor Stator Geometry and low rubbing velocities are ideal for the Sewage & Effluent treatment applications. These Pumps are available in Close Coupled & Bareshaft Configuration.

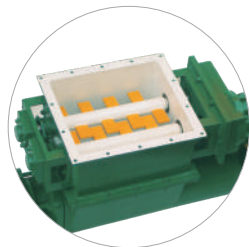

### **Wide Throat WM series**

Capacities upto 150 M<sup>3</sup>/hr  
Pressures upto 36 Bar

Wide throat type inlet allows gravity flow of highly viscous (Plastico-viscous) material on to Augur-on-Coupling Rod which pushes the substance to the pumping element. Widethroat pumps with bridge breaker arrangement at the top are designed for handling extremely difficult media with very high solid content and non-flowing properties. Available in Close Coupled & Bareshaft Configuration. Custom designed hopper is possible.



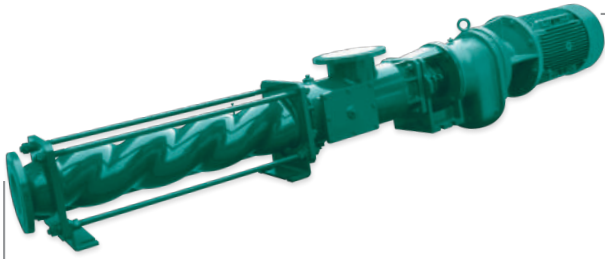

### Heavy Duty RE series

Capacities upto 100 M<sup>3</sup>/hr  
Pressures upto 48 Bar

These Heavy Duty industrial pumps are compact and are designed for high pressures due to equal wall stators which are capable of generating 12 bar per stage.



### Robust and Compact GD series

Capacities upto 15 M<sup>3</sup>/hr  
Pressures upto 12 Bar

These heavy duty agriculture duty pumps are designed to handle the day to day pumping needs like pumping animal effluent, salty water, water containing sand or silt, domestic water supply. With excellent suction lift capabilities. These pumps are available in bare shaft and close coupled configurations.



### Wine & Beverage DM series

Capacities upto 86 M<sup>3</sup>/hr  
Pressures upto 24 Bar

These Heavy Duty semi-hygienic pumps are specifically designed for Wine & beverage transfer applications and can also be used for other Food & Beverages applications. Standard connections include IDF, SMS & RJT.

### Submerged Vertical VM series

Capacities upto 420 M<sup>3</sup>/hr  
Pressures upto 12 Bar

These vertical pumps are designed to operate with the pumping elements immersed in the product. These pumps are compact and space saving. They are custom designed and manufactured for varying column lengths to suite the sump depth.

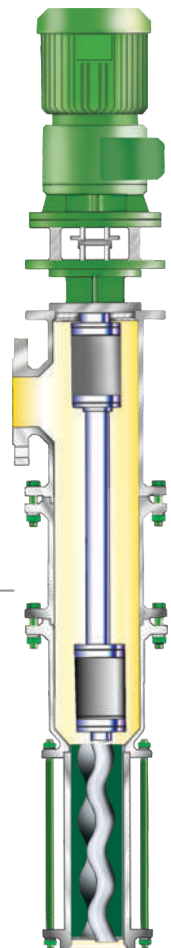

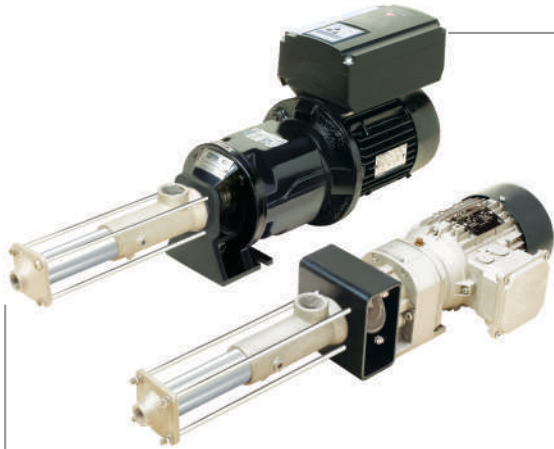

### **Metering Pump RJ series**

Capacities between 0.68–500 LPH

Pressures upto 24 Bar

These pumps are developed for low flow applications that demand high accuracies and repeatability. These pumps can handle wide variety of fluids ranging from clean and clear liquids to abrasive, corrosive, viscous and solid laden media. The repeatability accuracy has less than 1% fluctuation. Available in 6 capacities and 3 pressure ranges.



### **Light Industrial and Agriculture DC series**

Capacities upto 8 M<sup>3</sup>/hr

Pressures upto 3 Bar

The most versatile pump for light industrial, agricultural & domestic applications UV resistant Acetyl-co-polymer housing for pump sizes 11, 12 & 31 Cast Iron casing for pump sizes 41 & 51. Simple and easy to maintain. Compact and light weight. These pumps are available in bare-shaft and close coupled versions. Standard IEC frame sized motors.



### **Mini Range MC series**

Capacities upto 3.5 M<sup>3</sup>/hr

Pressures upto 3.5 Bar

These pumps are designed for use where low flow or transfer duties in both domestic and industrial applications are required, Excellent suction lifts capabilities up to 8 metres on water. Suitable for a wide range of light industrial applications. Available in close coupled configurations only. Standard IEC frame motors.



### **General Purpose SC series**

Capacities upto 12 M<sup>3</sup>/hr

Pressures upto 3.5 Bar

These General purpose pumps are compact and light weight, designed for transfer duties in both domestic and industrial applications. Excellent suction lifts up to 8 metres on water. Suitable for a wide range of light industrial applications.

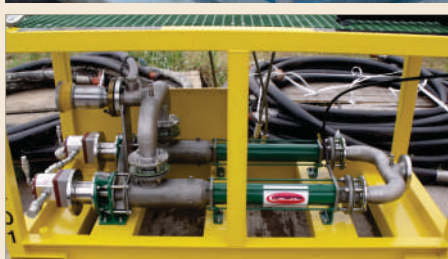

## Water and Waste water

Digested Sewage Sludge, Activated Sludge, De-Watered Effluent Sludge, Bio Sludge, Industrial Effluents, Poly Electrolytes, Flocculants, Oily Sludge, Oilwater separation, Lime dosing, Alum Feed, Scum

## Sugar

Sulphited Sugar Juice, Masseccuite, Magma, Melt, Molasses, Phosphoric acid, Milk of Lime, Flocculant Dosing, Effluent Sludge

## Pulp and Paper

Medium and High consistency Pulp, Titanium dioxide, Sodium Silicate, Alum, Latex, Kitchen Coating Slurry, Glue, Black Liquor, Calcium carbonate, Starch slurry, cooked starch, colour, Resin

## Detergents Cosmetics & Toiletries

Creams, Shampoo, Heavy liquid emulsion, Lotion concentrate, Selenium liquid, Liquid make up, Tooth paste, Soap solution

## Oil and Gas

Drilling mud, Oil sludge, skimming, waste, Skimmer oil from API, Oil & wax mixture, Multiphase fluid transfer, Crude oil & water transfer, Offshore oil transfer, Produced water, Oil Water emulsion, Chemicals

## Paint & Varnish

Acrylic solution, Pigment slurry, Varnishes, Resins, Latex, Pigmented paints, Oil paste, Lacquer, Solvents, Paint premix

## Food and Pharma

Oil, Cheese, Milk, Yogurt/Curd, Lactose Paste, Cream, Condensed/ Concentrated Milk, Ice-cream, Soy bean concentrate, Taco sauce, Dough, Wheat milk slurry, Yeast, Cake mix, Chocolate, Honey, Syrups, Bulk drug slurries Ointments & Balms, Selenium liquid

## Breweries, Wineries & Distilleries

Spent grain & Yeast transfer, Beer & Wine, Decanted settlings, Diamatacious slurry, Fruit bunch with / without stock, Heavy de-juiced red wine mash, Thick mashes, Thick juices & cider, Must, Spent hops, Spent wash, Wet crushed malt

## Mining

Coal water mixtures, Clay & Mineral slurries, High pressure wash, Dirty water, Cement grout/Grout mix, Explosive mix transfer & filling, Mortar with fine aggregates, Water spray for dust suppression, Flocculant

## Marine

Mud, Brine, Bilge water, Sludge, Sewage, Waste oil

## Construction

Wall plastering, Fine aggregate mortar, Sealing compounds, Dispersion plaster, Floor screed, Interior & Exterior plaster, Plaster & Gypsum, Cement & Sand mixture, Cement slurry

## Ceramic

Clay coatings, Ceramic slurry, Clay slip, Fire clay suspension, Filter press suspension, Glaze, Iron oxide slip, Kaolin, Slaked lime, Bentonite slurry, Color paste

## Agriculture

Pumping Salty water, Effluent field irrigation, Pumping animal effluent, Stock and domestic water supply, Pumping water containing sand or silt, Transfer from dams or creeks, Bio sludge, Animal feed transfer, Surface water transfer for cattle, Preparing & conveying pasty animal feed, Molasses animal feed

## Edible Oil

Cooking oil, Soy Bean concentrate, Peanut butter, Refined oil Lecithin, De odorised oil, Oil with wax, Fatty acids, Gums, Acid oil, Soapstock, Crude Palm oil, Bleached palm oil, Mustard oil, Soap Stock

## Chemicals

Acetone, Alum, Alumina slurry, Barium carbonate slurry, Benzene & polymer, Boric acid solution, Plutonium oxide, Polyphosphoric acid, Sodium bisulfate, Sodium peroxide, Terephthalic acid, Zinc oxide, Zinc slurry, Zinc & Nickel hydrates

## Man made fibre

Viscose, Viscosev flakes, Pulp with Sodium Hydroxide, Fixing Agents, Bleaching Agents, Flocculants, ETP sludge



## Twin Screw Range of Pumps

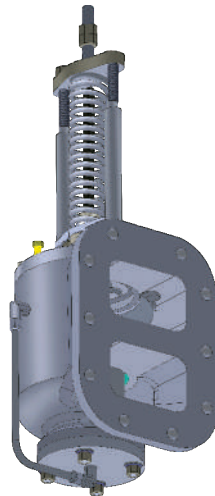

### Built in Safety Relief Valve

To prevent the excessive pressure built up in the system, the built in safety relief valve is capable of 100% bypassing of fluid.

### Robust Pump Housing

The pump housing are available in casted or fabricated options. The casings are designed to take care of the flange loads. The suction flange and the casing offer minimum resistance to the flow of liquid thus minimising the NPSH requirements within the pump.

Standard Pump casing are foot mounted and non jacketed. Options are available for centre line mounting, sump heated and steam jacketed.

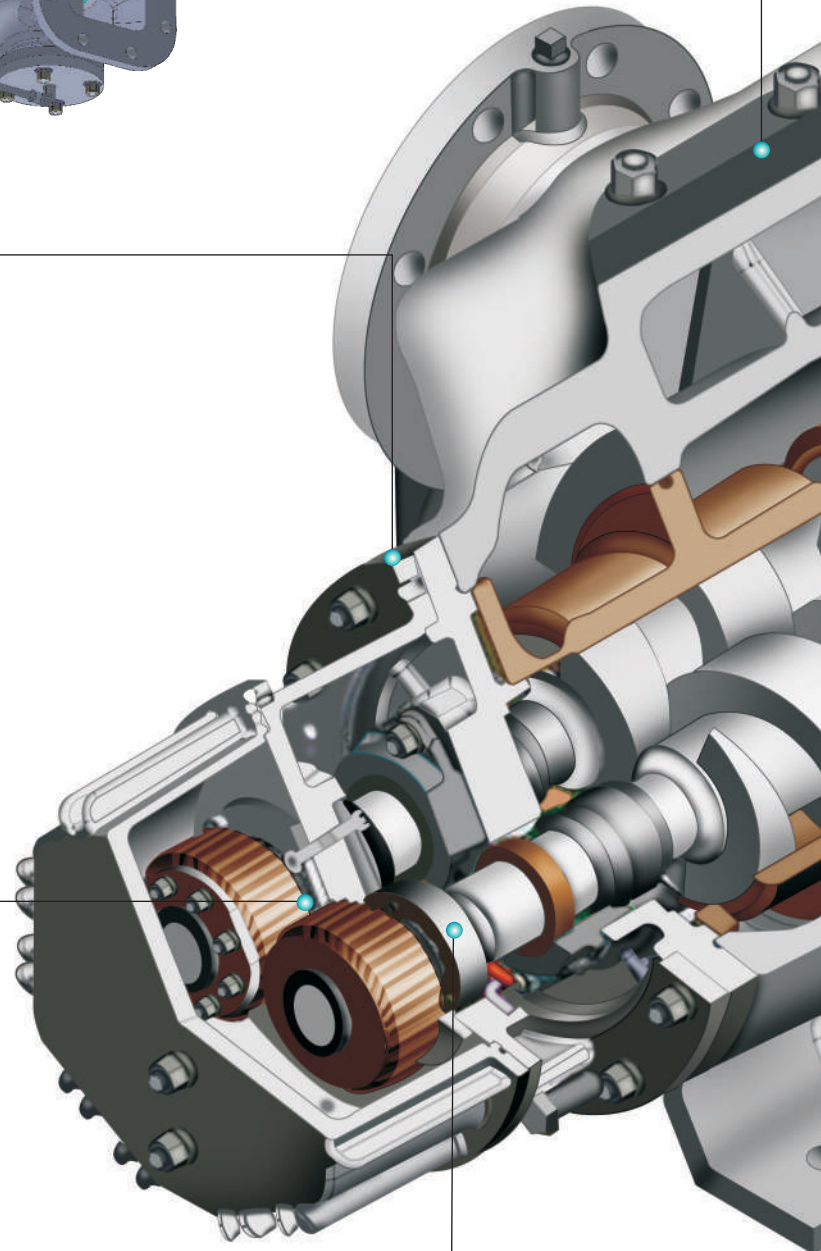

### Timing Gear

Timing gear are housed in the gear box. The gear are hardened steel spur gears which are capable of transmitting higher torque and also maintain the clearances between the two screws resulting into longer service life. The gears are oil lubricated and away from the pumping liquid.

### Spherical Roller Bearings

Fitted at both the ends, they are well suited for radial and axial loads arising out of Hydraulic pressure. And can also take care of the misalignments arising due to unforeseen working conditions at site.

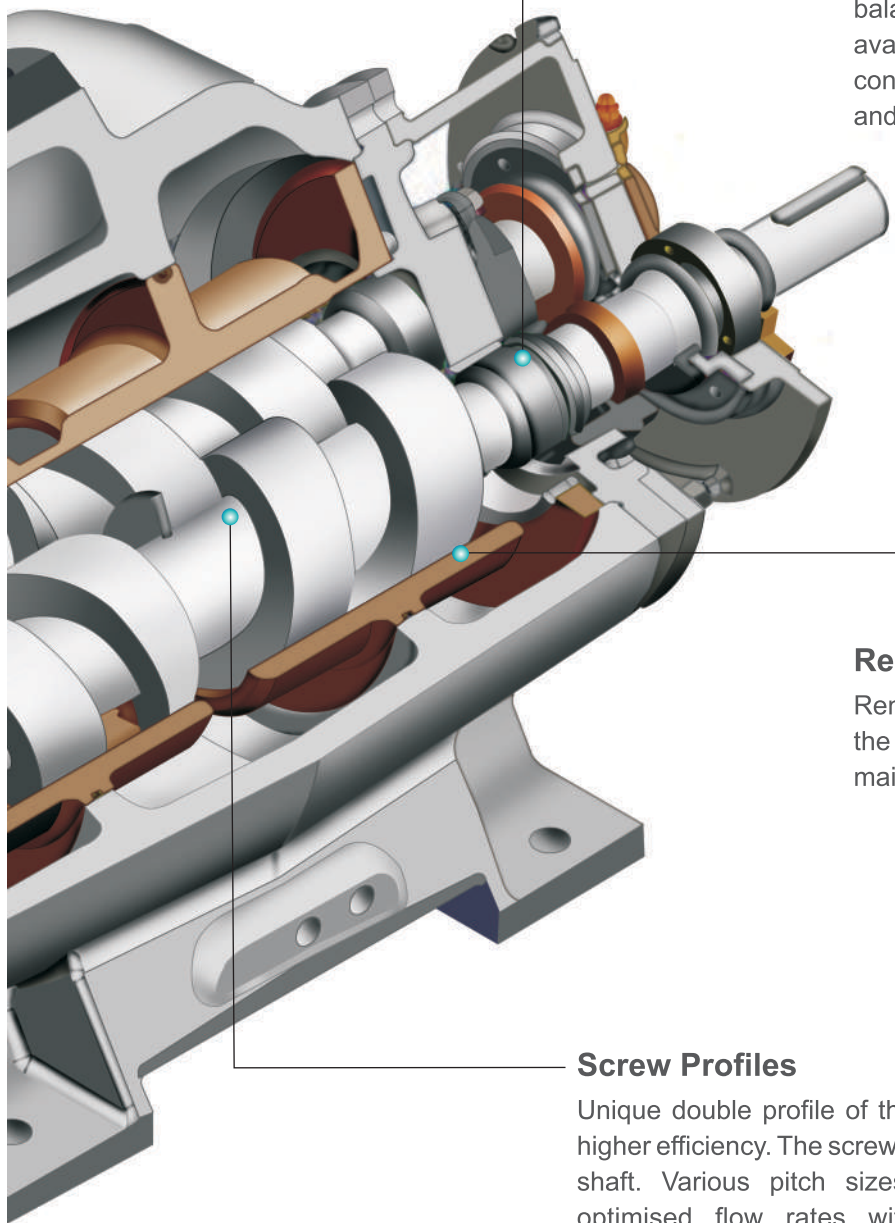

### **Shaft Sealing**

These pumps can accommodate various types of shaft sealings like soft gland packing, single unbalanced, balanced and double mechanical seals. Options are available for pumps fitted with mechanical seals conforming to API 682 standards and various flushing and quenching plans.

### **Replaceable Liner**

Renewable liners are standard feature. They extend the service life of the pumps and also minimise the maintenance cost over a long period.

### **Screw Profiles**

Unique double profile of the screw flanks delivers a higher efficiency. The screw flanks are integral with the shaft. Various pitch sizes are available to offer optimised flow rates with high volumetric and mechanical efficiencies. These screws are also suitable for high pressure applications.



### **Horizontal External Bearing RE series**

Capacities upto 500 M<sup>3</sup>/hr

Pressures upto 40Bar

Due to its external bearing mounted design, the product does not come in contact with the bearings and ensures long service life even with the corrosive or abrasive nature fluids. These pumps can handle fluids with high temperatures upto 350° C / 660° F. API 682 type seals can be mounted. Built in safety relief valve designed for 100% bypass.

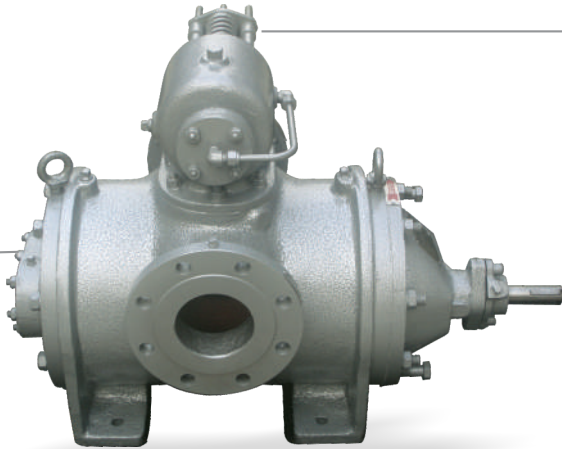

### **Horizontal Internal Bearing RE series**

Capacities upto 500 M<sup>3</sup>/hr

Pressures upto 40Bar

These pumps are designed for clean and lubricating media. The pumps are fitted with the bearings inside and the bearings are lubricated with the pumping media itself. Available in standard foot mounted configuration with sump heating arrangement as an option. Built in safety relief valve designed for 100% bypass.



### **Vertical Internal / External Bearing RV series**

Capacities upto 500 M<sup>3</sup>/hr

Pressures upto 40Bar

These pumps are designed to suite the areas where space is a constraint. They are available in internal as well as external bearing configurations. These pumps can handle fluids with high temperatures upto 350° C / 660° F with or without steam jacketing, electrical/steam tracing arrangement as an option. API 682 type seals can be mounted. Built in safety relief valve designed for 100% bypass.



# Applications

## Oil and Gas production and processing

Crude oil, Naptha, Vaccum residue , LFO, Fuel oil , LDO, LSHS, HSD, Turbine oil , Furnace oil ,Lubricating oil, Bitumen, RFO

## Power Plant

Fuel oil, LDO, LSHS, HSD, Turbine oil, Furnace oil, Lubricating oil, RFO

## Marine and Ship Building

Fuel oil, Striping duty, Bitumen, Pitch, Molasses, Glycol, Vegetable oils, Chemicals, Main Engine Lube oil, HFO transfer, Hydraulic oil, Marine Diesel oil

## Man Made Fibre

Viscose, Viscose Flakes , Pulp with NaOH , Bleaching Agents , Polymeric Resin

## Steel

Fuel oil , LDO, LSHS, HSD, Turbine oil , Furnace oil, Lubricating oil, RFO, Tar

## Paper

Fuel oil , LDO, LSHS, HSD, Turbine oil , Furnace oil, Lubricating oil, Black Liquor, Pine oil

## Sugar

Fuel oil , LDO, LSHS, HSD, Turbine oil , Furnace oil, Lubricating oil, Molasses

## Fertilizer

Fuel oil, LDO, LSHS, HSD, Turbine oil , Furnace oil, Lubricating oil

## Edible Oil

Cooking oil, Soy Bean concentrate, Refined oil, Lecithin, De odorised oil, Oil with wax, Fatty acids , Crude Palm oil , Bleached Palm oil, Mustard oil, Soap Stock

# Roto@work

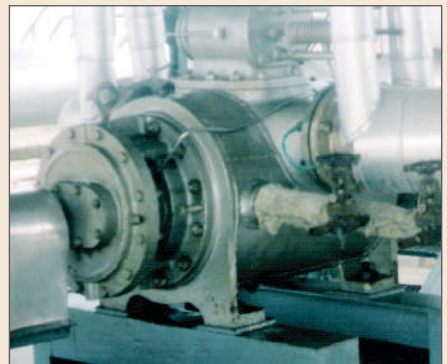
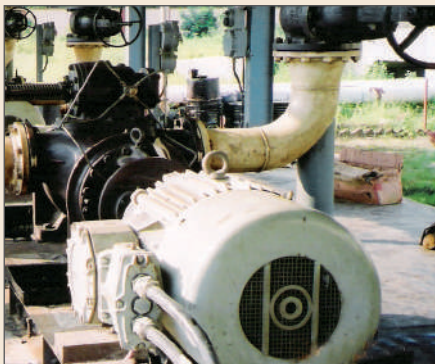
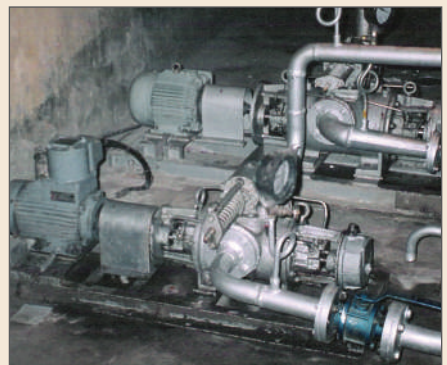
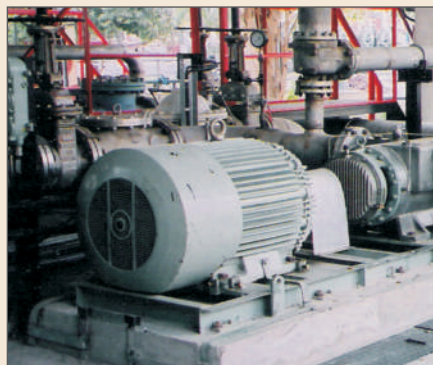
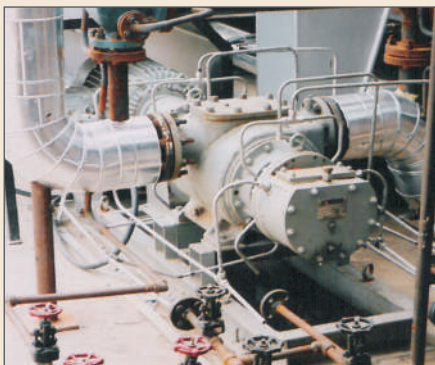
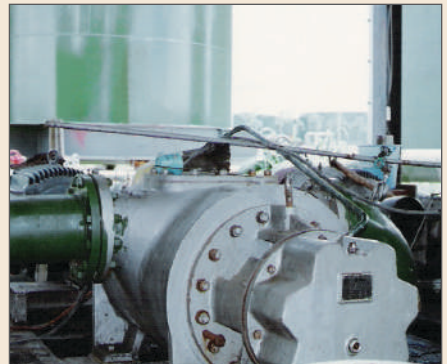
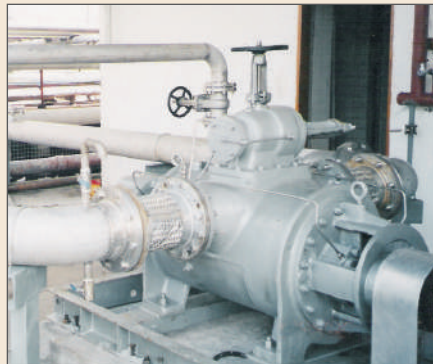

# Retrofit Parts for Progressive Cavity Pumps

Roto Pumps is one of the world's leading manufacturer of Progressive Cavity Pumps. Its experience spans over 45 years in designing, manufacturing and supplying Progressive Cavity Pumps. At Roto it is not simple re-engineering but intelligent engineering. No wonder, more and more customers are finding Roto's progressive parts outperforming the originals.

## Progressive Spares for

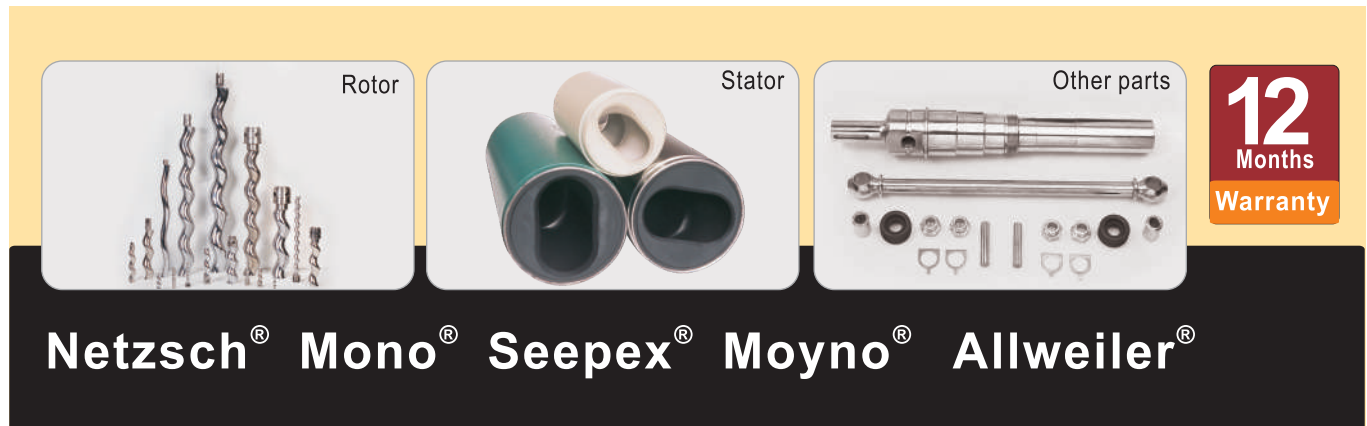

Rotor

Stator

Other parts

**12**  
Months  
Warranty

**Netzsch® Mono® Seepex® Moyno® Allweiler®**

These are registered trade mark of Seepex/Mono/Moyno etc.

## Material Options

Rotor	Stainless Steel, Tool Steel and Exotic Alloys
Stator	Natural, Nitrile, Food Grade White Nitrile, HNBR, EPDM, Chloro-Sulphonated Elastomer, Fluoroelastomer and AFLAS®
Other Parts	Stainless Steel, Tool Steel and Exotic Alloys

## Coating Options

Hard Chrome Plating, Rotochrome and Other Special Hard Coatings



Netzsch®, Monoflo®, Seepex®, Moyno® & Allweiler® are registered trademarks of Netzsch Mohnopumpen GmbH, Mono Pumps Ltd., Seeberger GmbH + Co KG, Robbins & Myers, Inc. & Allweiler AG respectively. AFLAS® is a registered product of Asahi Glass Co. Ltd., Japan.

Roto Pumps is not an authorised distributor of parts or services for Netzsch Mohnopumpen GmbH's, Monoflo, Seeberger GmbH's, Robbins & Myer's Inc. and Allweiler AG's products. Roto Pumps Ltd. products are not associated with, endorsed by, or sponsored by these companies.



## After Sales Support

At Roto Pumps, we believe when you become a customer, our job just begins. Just as we design and develop superior pumps, we have a strong service philosophy to support it. It is important for you to know how to install and operate your pumps correctly, that you receive the support you need to your particular application, and should the need arise – you receive prompt, courteous and knowledgeable after sales support. Our goal is to ensure your process is successful.

We offer following after sales services:

### **Installation and Commissioning Support**

It is performed at your facilities by our expert representatives and technicians. The initial training is a part of the installation services.

It is advisable to avail the expert advice of our representatives and technicians for the safety of your processes and the longevity of your Roto Pumps.

### **Preventative Maintenance /Annual Maintenance Contracts**

We offer full service contracts including spare parts for our own pumps as well as pumps of other makes. We also offer energy audit of your pumps and pumping system analysis program.

### **Training**

Roto Pumps conducts frequent training programs at customer site for operation & maintenance. This enhances the awareness and optimum utilization of Roto Pumps that are operating in your plant. You can call our nearest office to you for your training requirements. Our experienced team would visit you and provide the necessary training.

All products purchased from Roto Pumps or our partners are fully supported by our After Sales Service team.

For more information, please visit us at [www.rotopumps.com](http://www.rotopumps.com) or mail us [contact@rotopumps.com](mailto:contact@rotopumps.com)







## **ROTO PUMPS LTD.**

### **Marketing Head Office**

Roto House,13, Noida Special Economic Zone, Noida - 201305, INDIA  
Tel.: +91 120 2567902-5 Fax: +91 120 2567911  
Email: [contact@rotopumps.com](mailto:contact@rotopumps.com)

### **Branch Offices and Warehouses**

#### **United Kingdom**

Unit 1 St Elizabeths Park, Grey Street, Denton, Manchester, M34 3RU  
Tel.: +44 161 4775511 Fax: +44 161 4747900  
Email: [sales@rotopumps.co.uk](mailto:sales@rotopumps.co.uk)

#### **Australia**

26, Deans Court, Dandenong South, Victoria 3175  
Tel.: +61 3 97945200 Fax: +61 3 97945900  
E mail: [melb@rotopumps.com.au](mailto:melb@rotopumps.com.au)

### **Subsidiaries**

#### **Roto Pumpen GmbH**

Am Brühl 17, 32423 Minden, Germany  
Tel: +49 571 40410077,  
Email: [lange-burchard@rotopumpen.de](mailto:lange-burchard@rotopumpen.de)

#### **Roto Pumps North America, Inc.**

9023 E 46th St, 472192,Tulsa, Oklahoma 74147  
Tel: +1 918 280 9144,Fax: +1 918 806 6853  
Email: [info@rotopumps.us.com](mailto:info@rotopumps.us.com)

[www.rotopumps.com](http://www.rotopumps.com)