

811 ANSI Series

PRODUCT BROCHURE

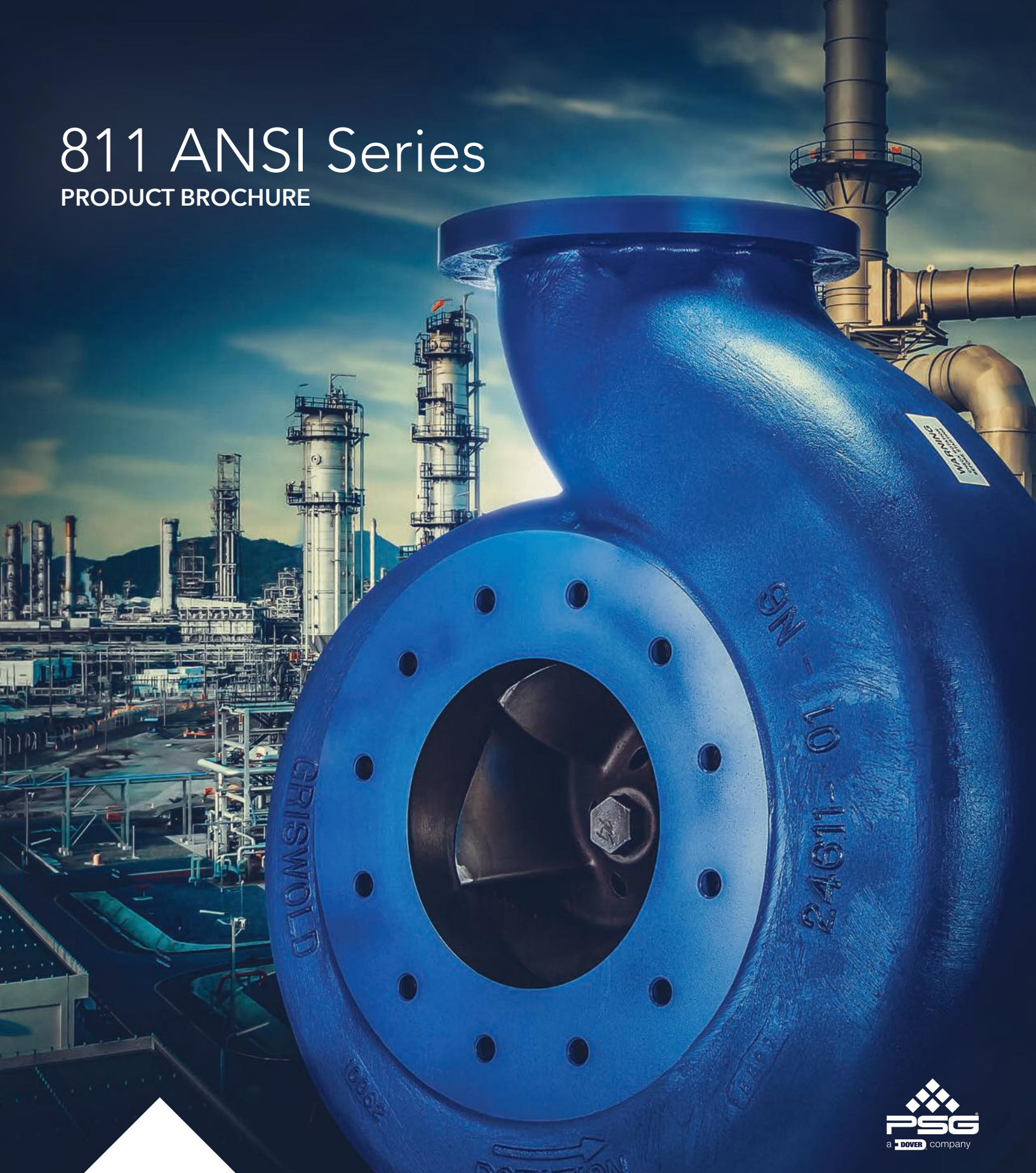

Where Innovation Flows

Centrifugal Pumps



Griswold™ Centrifugal Pumps

Griswold™ is a premier manufacturer of centrifugal pumps and baseplate systems. With engineering expertise, lean manufacturing, testing capabilities, and exceptional customer support, Griswold meets its customers' most demanding application requirements, all while minimizing project costs.

Are All ANSI Pumps the Same?

In 1974, the American National Standards Institute (ANSI) established manufacturing criteria for centrifugal pumps to ensure that the demanding needs of the chemical-processing industry are met. Mandatory design features- such as self-ventilation, foot mounting, centerline discharge and back pull-out- became the industry's assurance that complying pumps met production and safety needs.

Even though ANSI compliance would seem to level the playing field for pump specification, your choices are actually far more complex. The fact is that many brands just meet the minimum requirements of this standard, and a pump is far more than just its specifications. While other brands may offer similar features and performance, you may experience inflated cost, delayed delivery and deflated service. In a market where all ANSI pumps seem the same, dare to compare.



OIL & GAS



CHEMICAL PROCESS



MINING



ENERGY



WATER



PROVEN TRACK RECORD OF PERFORMANCE

COMPARE

- 811
- other brands

The Griswold 811 ANSI Series offers the best pumps you'll find on the market. Engineered for exceptional performance and maximum flexibility, the 811 ANSI Series go the distance in the harshest and most difficult fluid-processing applications. The Griswold 811 ANSI Series centrifugal pump was among the first pump designs to comply with the new ANSI standards in the 1970s. More than 50 years of proven performance has enabled Griswold to focus on enhancing its ANSI pump features and support offerings to surpass the industry standard and exceed customer expectations.

EXTENDED EQUIPMENT LIFE

COMPARE

- 811
- other brands

In addition to exceeding ANSI construction requirements, the 811 ANSI Series include several features that are critical to long-term operational reliability. To start, the open impeller and seal chambers are designed to facilitate corrosive and erosive substance transport, heat regulation and routine maintenance. The 811 ANSI Series range of enhanced power frames and rigid baseplates combine the latest technology with the highest quality construction to minimize the effects of work forces and shaft deflection, optimize cooling and further simplify the installation and maintenance process. All told, you can expect the 811 ANSI Series to continue performing long after other ANSI centrifugal pumps wear out or break down.

REDUCED INITIAL & TOTAL COST OF OWNERSHIP

COMPARE

- 811
- other brands

You may have heard that the initial cost of your pump and parts plays a minor role in your total cost of ownership. NOT TRUE! With the Griswold 811 ANSI Series, you get identical quality and longevity as the best-known brands—at a lower initial price. Factor in low cost on parts and the long-term savings are even greater! This translates into the industry's LOWEST total cost of ownership.

GENUINE PARTS & PART-FOR-PART INTERCHANGEABILITY

COMPARE

- 811
- other brands

When meeting your production quota is compromised, waiting for repairs can mean significant losses in revenue (which is another factor in true cost of ownership). The Griswold 811 ANSI Series and an extensive inventory of parts are 100% interchangeable with hundreds of thousands of other ANSI pumps currently in use. With stocking distributors from coast-to-coast and throughout the world, you can be up and running before you even get a response call from the competition!

Engineered for Flexibility & Durability



TECHNOLOGY: CENTRIFUGAL PUMPS

811 ANSI Series

The 811 ANSI Series is available in a wide range of sizes, capacities and materials to fit virtually any process-fluid application. With more than 30 selections and multiple design options, we've got your application covered - for abrasives, corrosive substances and a wide range of capacities.

Applications

- Oil & Gas
- Chemical
- Petrochemical
- Water Treatment
- Pulp & Paper
- Breweries
- Grain Processing
- Food Processing
- Poultry Processing
- Automotive
- Pharmaceutical
- Steel
- Semiconductor
- Power Generation
- Textile

Features & Benefits:

- ASME (ANSI) B73.1-compliant
- Magnetic drain plug
- Extra-large capacity epoxy-coated oil sump
- Registered alignment between frame and adapter
- Standard and low-flow models available
- Heavy-duty power frames
- Fully open impellers with rear-adjustment capability
- Wide variety of mechanical seal options
- Dynamically balanced impellers
- Factory certified, high quality genuine parts
- Part-for-part interchangeable with other centrifugal pumps

Technical Data:

- Ductile iron, CF8M (316) stainless steel, CD4MCuN and Alloy 20 materials available
- Max. temperature: 500°F (260°C)
- Three stuffing-box options available
- Multiple port sizes available
- Multiple seal-flush plans available
- Steel and composite baseplates available
- Certified testing per Hydraulic Institute and material certifications per ASTM

Performance Data:

- Max. flow: 7,000 gpm (1,590 m³/hr)
- Max. head: 900 ft (275 m)

CERTIFICATIONS & ASSOCIATIONS:



ASME (ANSI) B73.1

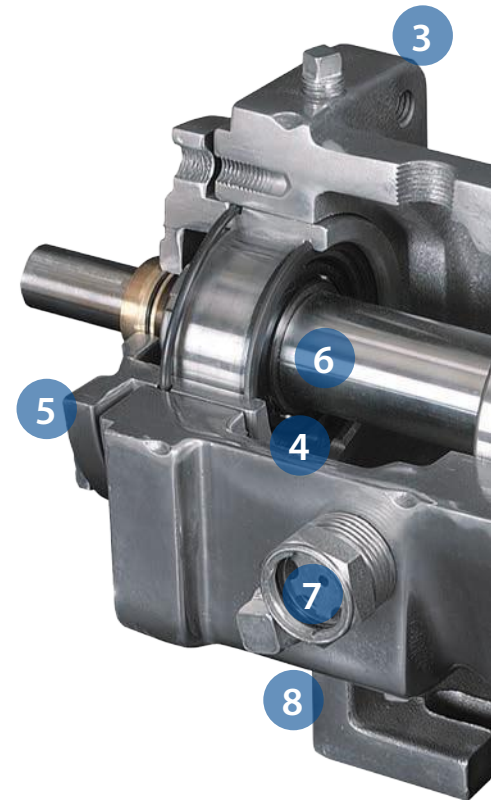

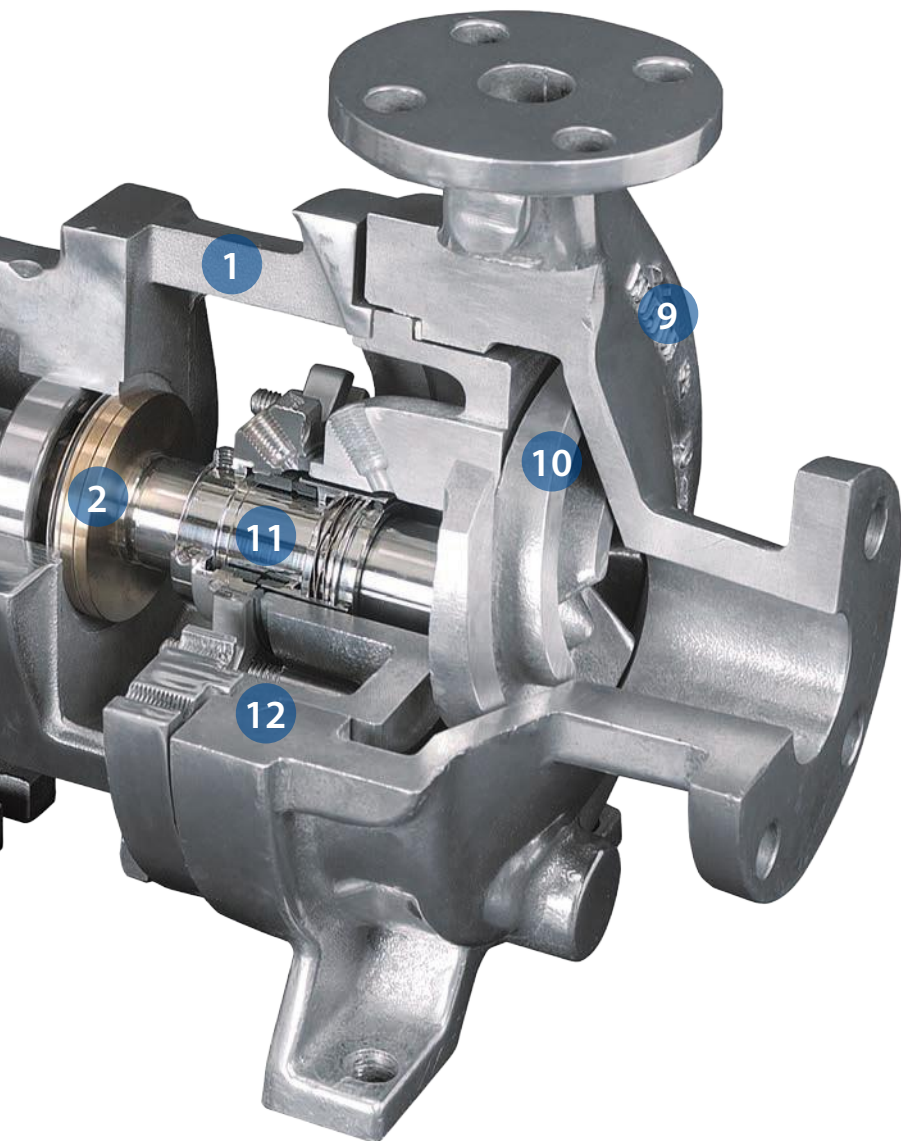

6 Heavy-Duty Shaft and Bearings

Engineered to minimize vibration and shaft deflection, less than 0.002 inch per ASME (ANSI) B73.1, optimizing pump life. Sleeved and solid shaft available in a variety of materials. Bearings sized for 10-year life expectancy under tough operating conditions.



7 Oversized Sight Glass

One-inch bullseye reflective sight glass facilitates monitoring oil level and condition, critical to bearing life. Bottle oiler optional.

8 Magnetic Drain Plug

Collects damaging metallic contaminants away from the bearings.

9 Extra-Heavy Casings

All Class 150 pumps are produced with the same heavy-duty wall thicknesses as Class 300 pumps for extended reliability and casing life under severe corrosive/erosive conditions:

- Top centerline, self-venting discharge for air handling
- Back pullout to simplify maintenance
- Rigid casing feet prevent pipe-load misalignment and promote seal/casing life
- Discharge connection for pressure gauge or seal bypass-flush connection standard on ductile iron and stainless steel casings
- Class 150 FF standard for positive sealing; optional Class 150 RF/300 FF/RF available
- Casing drain standard in ductile iron and stainless steel for simplified maintenance

10 Fully Open Impeller

With double the wear area of enclosed models, the 811 ANSI Series impeller offers superior handling of solids, corrosives and abrasives. Back pump-out vanes reduce hydraulic loads and seal chamber pressure.



11 Sealing Flexibility

Wide range of sealing options coupled with seal chambers and stuffing boxes selected for service condition to improve lubrication and heat dissipation of seal faces, maximizing pump uptime.

12 Contained Casing Gasket

Provides positive sealing at casing joint to prevent "blow out" of liquids and to facilitate disassembly.

1 Ductile Iron Frame Adapters

Ductile-iron construction provides strength and safety. Precision machined to accurately align the liquid end to the power end. Large openings simplify installation and maintenance. Includes jacking bolts to facilitate disassembly.

2 Labyrinth Seals Standard

INPRO® oil seals keep outside contaminants from lubrication media, significantly extending bearing life. Standard in bronze. Carbon-filled PTFE and magnetic face seals optional.

3 Mounting Frame Flange

Machined to accommodate C-face motor adapters.

4 Extra-Large Capacity Powder-Coated Oil Sump

Maximized oil capacity delivers improved heat transfer and oil temperature, greatly extending bearing life. Designed to accommodate optional fin coolers for high-temperature applications. Impenetrable fusion-bonded epoxy coating on interior surface extends quality, cleanliness and longevity of the lubricating oil.

5 External Clearance Adjustment

Designed for maintaining original flow, pressure and efficiency, minimizing energy consumption and repairs, and extending mean time between repairs (MTBR).



811 ANSI Series Options

Seal Chambers & Sealing Flexibility:

Our quality seal chambers are engineered to provide optimum seal environment for heat dissipation, solids, entrapped air and vapor. Oversized seal chambers increase radial clearance between the mechanical seal and seal chamber, as well as provide better circulation of liquid to and from the seal faces, preventing failure of the shaft seal. A variety of flush plans are available for additional lubrication and cooling of the seal faces.

Standard Bore	Large Bore	Tapered Bore
		

Services	Services utilizing packing or mechanical seals. For mild fluid at ambient temperatures.	Most services including those with solids greater than 10%. Increased radial clearance between seal and chamber for improved liquid circulation, lubrication and cooling.	Services up to 10% solids or those containing entrained air or vapors. For lower seal face temperatures, self venting and draining. Circulates solids and vapors away from seal faces.
Sealing Flexibility			
Packing	Most Services	Not Available	Not Available
Single Seal/No Flush	Not Recommended	Not Recommended	Services with Solids up to 10%
Single Seal/With Flush	Mild, Clear Fluids	Most Services Including Solids above 10%	All Services with Solids up to 10%
Conventional Double Seal with Seal Plan	Zero Leakage Applications	Zero Leakage Applications	Not Available
Cartridge Double Seal with Seal Plan	Zero Leakage Applications	Zero Leakage Applications	Zero Leakage Applications

Seals To Fit Any Application:

CARTRIDGE SEALS, COMPONENT SEALS & CONVENTIONAL PACKING

With Griswold's broad selection of seals, you can accommodate most any fluid and temperature for demanding chemical, petroleum, pharmaceutical and general industry applications. Our engineers can recommend the best seal to maximize your application and system life—including cartridge or component, single or double, inside or outside, balance or unbalanced seals or conventional packing.



Single Cartridge Seal



Double Cartridge Seal



Double Gas Barrier Seal



Single Inside Seal



Conventional Double Seal

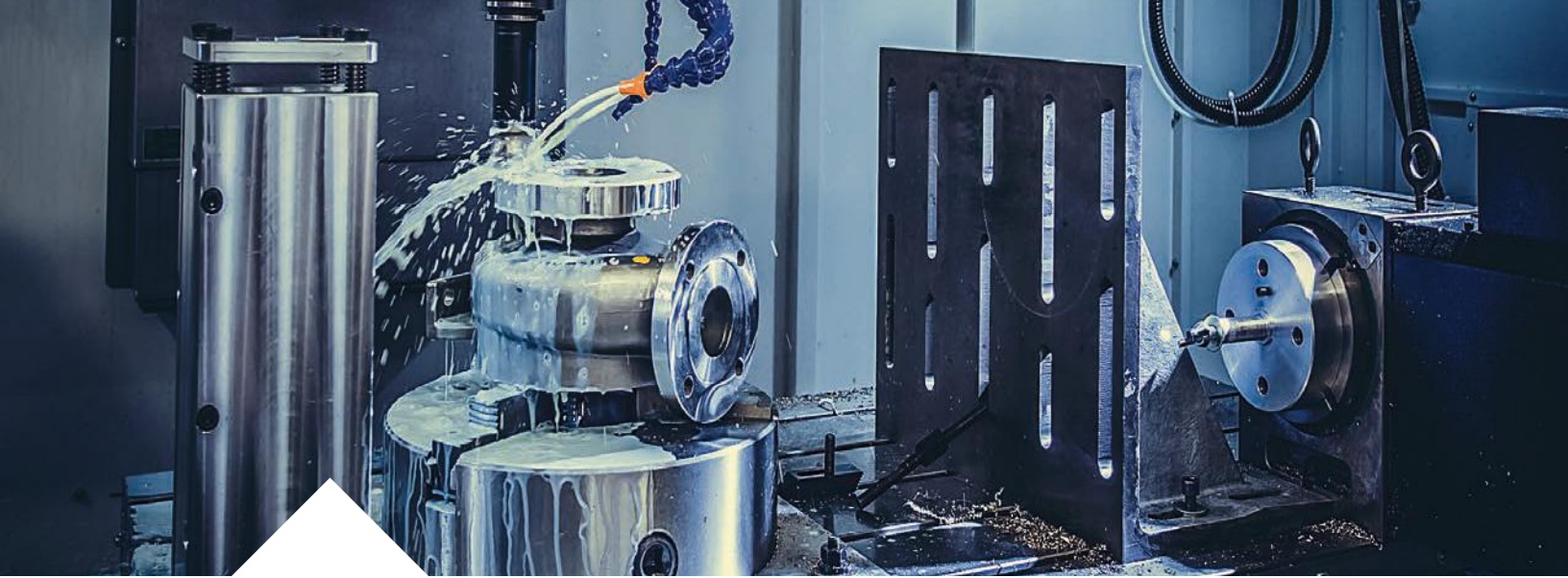

Extensive Options

Griswold offers a broad range of options and upgrades to tailor the 811 ANSI Series handling and performance to meet virtually any fluid-processing application. The Griswold engineering staff can assist you in configuring pump size, material and components to best suit your specific plant and processing requirements.

Lubrication Options

811 ANSI Series power ends accommodate all lubrication systems, including flood oil, oil mist and grease lubrication. The power ends are pre-drilled for all lubrication methods and can be easily converted in the field without modification.



Seal-Flush Plans

ASME (ANSI) B73.1 seal-flush and cooling plans are offered to control emission levels, improve lubrication and cooling of the seal faces, and reduce downtime. Ask for assistance in selecting the best plan.



Special Surface Preparation

Griswold offers a variety of optional surface-preparation processes for extended corrosion protection and contaminant-free pumping:

- Electro-Polishing
- Passivation
- Hard-Metal Coatings
- Fusion-Bonded, Epoxy-Coated Power End
- Special Paint Systems

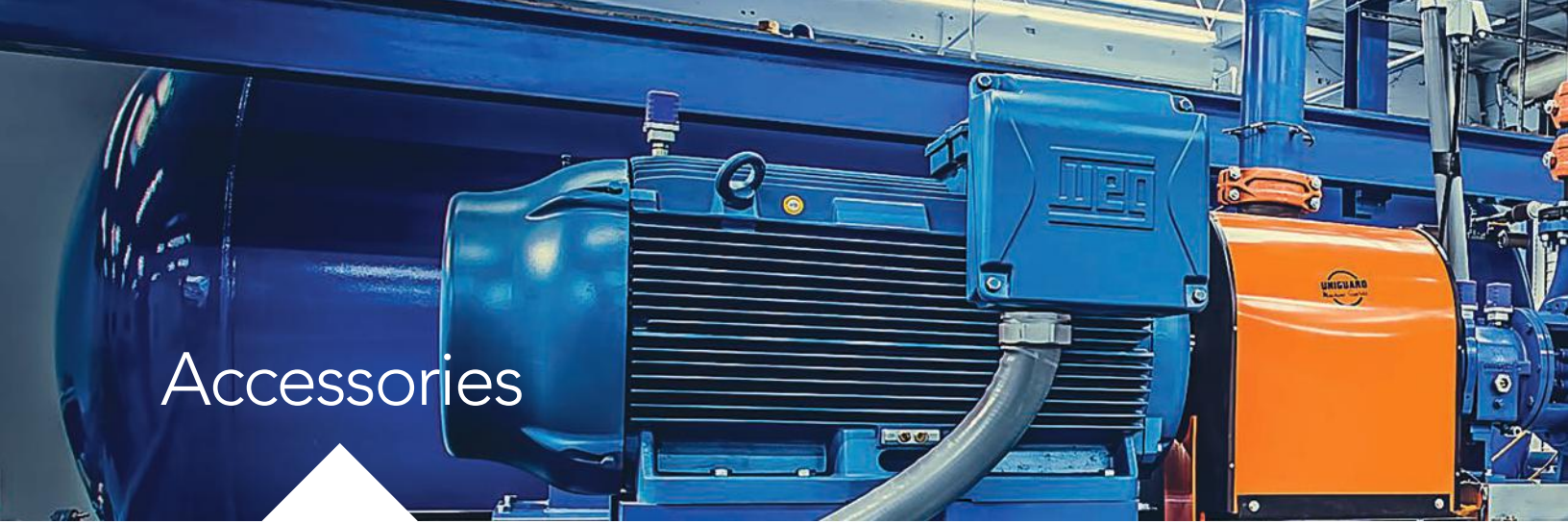

Accessories

Baseplate Mounting Systems

Griswold offers a complete range of pre-engineered rigid baseplates designed to reduce stress and vibration as well as extend MTBR, thus ensuring long-term durability. A wide selection of metallic and non-metallic baseplates provide flexibility in selecting the best base to fit your operating needs and budget. Bases include a fully enclosed steel coupling guard as standard with optional non-sparking coupling guard available.

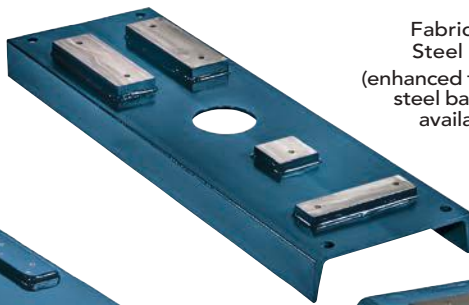

Fabricated Steel Base
(enhanced fabricated steel base also available)



Composite Base



Heavy Duty C-Face Motor Adapter

OPTIONAL FEATURE

The C-face motor adapter bolts directly to the precision machined fit on the power frame. The register fits on both ends of the adapter lock in a standard C-face motor, guaranteeing both parallel and angular alignments. This quick, yet precision installation minimizes time spent aligning shaft couplings, and eliminates seal and bearing replacements caused by misalignment. Best of all, the C-face adapters are directly interchangeable with most ANSI pumps.





Watchdog Oiler

OPTIONAL FEATURE

Watchdog oilers are designed to ensure the Griswold 811 ANSI Series power frame maintains a constant oil level in the event of a slight oil leak. The Watchdog oiler replaces the standard 1" sight glass on the power frame and have a viewport to easily verify adequate oil is present.



Drip Tray

OPTIONAL FEATURE

Griswold offers 316SS drip trays designed for all pump models. The drip trays are designed to be installed directly under the pump and have a 1/2" NPT drain port.



High & Low Temperature Capability

- Heat Jacket: Clamps onto the casing to manage heat transfer. Easy to install or remove for servicing.
- Jacketed Seal Chamber: Maintains temperature control for heating or cooling of sealing environment.
- Bearing Frame Finned Cooler: Directly cools oil to lower bearing temperature. Recommended for temperatures higher than 350°F (175°C).

811 ANSI Series Performance & Specifications

1750 1450 RPM Performance Coverage

Key:

- Small Frame (811S)
- Medium/Large Frame (811M and 811L)
- XL Frame (811XL)

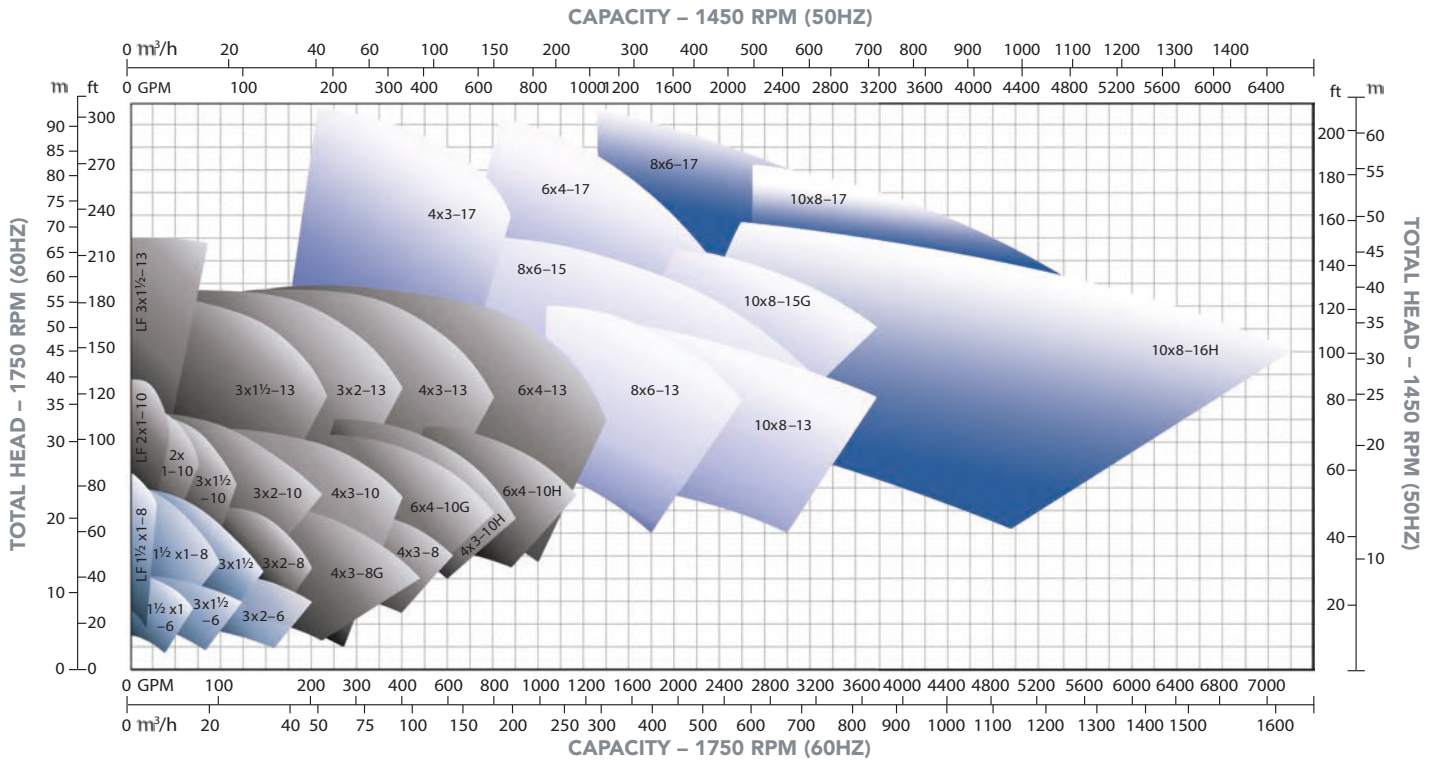

3500 2850 RPM Performance Coverage

Key:

- Small Frame (811S)
- Medium/Large Frame (811M and 811L)
- XL Frame (811XL)

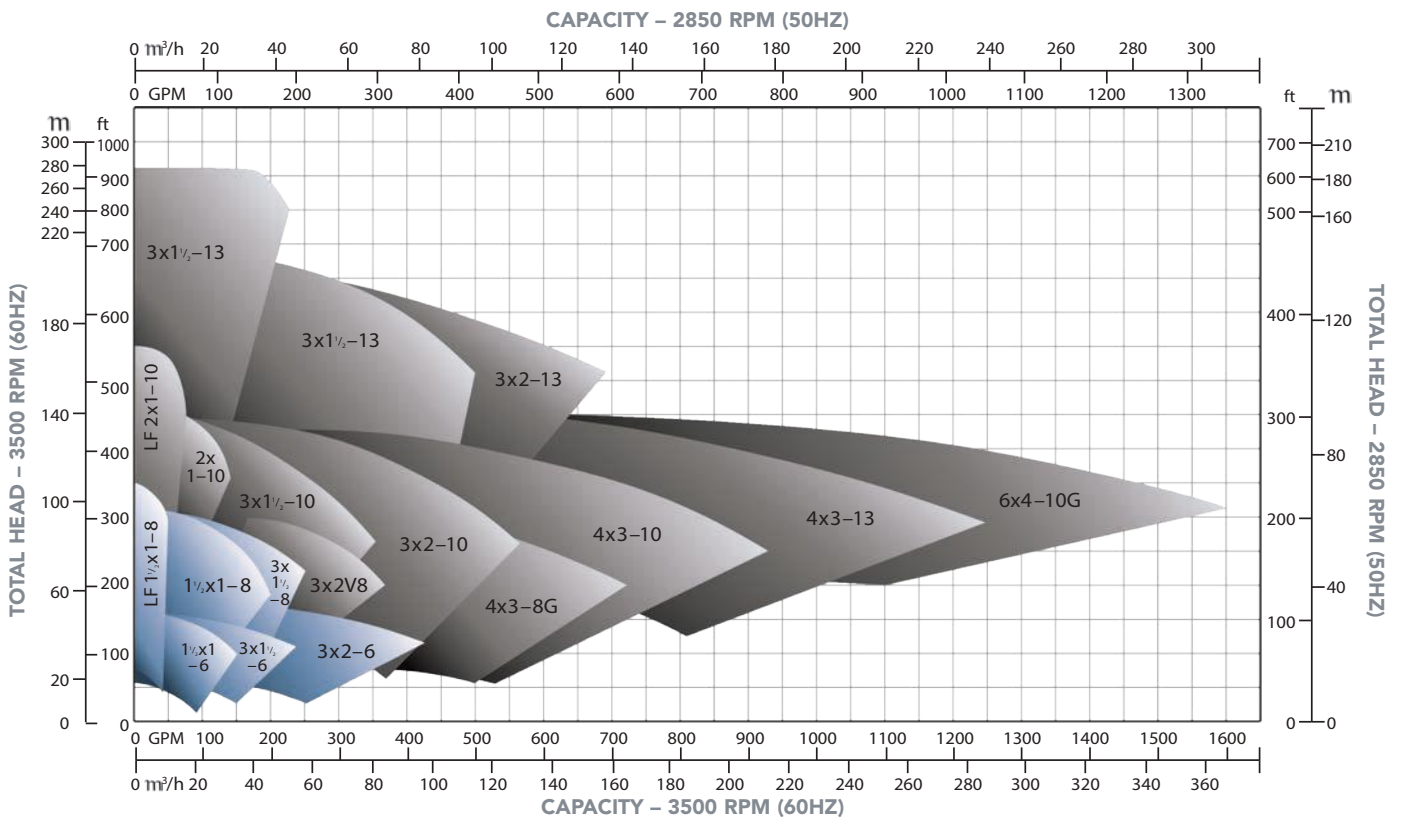

Materials/Casting Specs

DASH	MATERIAL	CASTING SPECIFICATION
N6	Ductile Iron	ASTM A395 Grade 65-45-15
91	316SS	ASTM A351 Grade CF8M
20	Alloy 20	ASTM A351 Grade CN7M
X4	Duplex	ASTM A995 Grade 1B (CD4MCuN)

B.H.P. Limits

R.P.M.	MODEL				
	811S	811M	811L	811XL	811XL17
3560	40.0	122.0	200.0		
2900	32.6	99.4	162.9		
1780	20.0	61.0	100.0	250.0	350.0
1450	16.3	49.7	81.5	203.7	285.1
1180	13.3	40.4	66.3	165.7	232.0
880	9.9	30.2	49.4	123.6	173.0

Construction Details

Griswold 811 Model		Model 811S	Model 811M	Model 811L	Model 811XL	Model 811XL17
Corrosion Allowance @ Max.		0.125				
Max. Allowable Working Pressure (MAWP)		See Pressure/Temp. charts above				
Hydrostatic Test Pressure		150% MAWP at 100°F (38°C)				
Max. Liquid Temp.		350°F (177°C) without Cooling / 500°F (260°C) with Cooling				
Shaft Diameter	At Coupling (in.)	0.875	1.125	1.875	2.375	2.375
	Sleeve Dia. Under Seal (in.)	1.375	1.75	2.125	2.50	2.50
	Under Impeller (in.)	0.75	1.00	1.25	1.50	1.50
	Under Sleeve (in.)	1.125	1.50	1.875	2.00	2.25
	Overhang (in.)	6.125	8.375	8.375	9.97	9.97
Bearings	Radial	SKF 6207	SKF 6309	SKF 6311	SKF 6313	SKF 6313
	Thrust	SKF 5306 A/C3	SKF 5309 A/C3	SKF 7310 BECBM	SKF 5313 A/C3	SKF 5313 A/C3
	Bearing Span	4.125	6.75	6.875	9.25	9.25
Mechanical Seal Size (in.)		1.375	1.75	2.125	2.50	2.50
Stuffing Box Standard Bore	I.D. (in.)	2.00	2.50	2.875	3.375	3.625
	Depth (in.)	2.125	2.625		3.00	3.00
	Distance End of Box to Nearest Obstruction	2.50	2.813		2.978	2.978
Stuffing Box Large Bore	I.D. (in.)	2.875	3.50	3.875	4.75	4.75
	Depth (in.)	2.125	2.125		3.00	3.00
	Distance End of Box to Nearest Obstruction	2.50	2.813		2.85	2.85
Lantern Ring Width (in.)		0.438	0.625		0.625	0.625

811 ANSI Series Parts, Materials, and Interchangeability

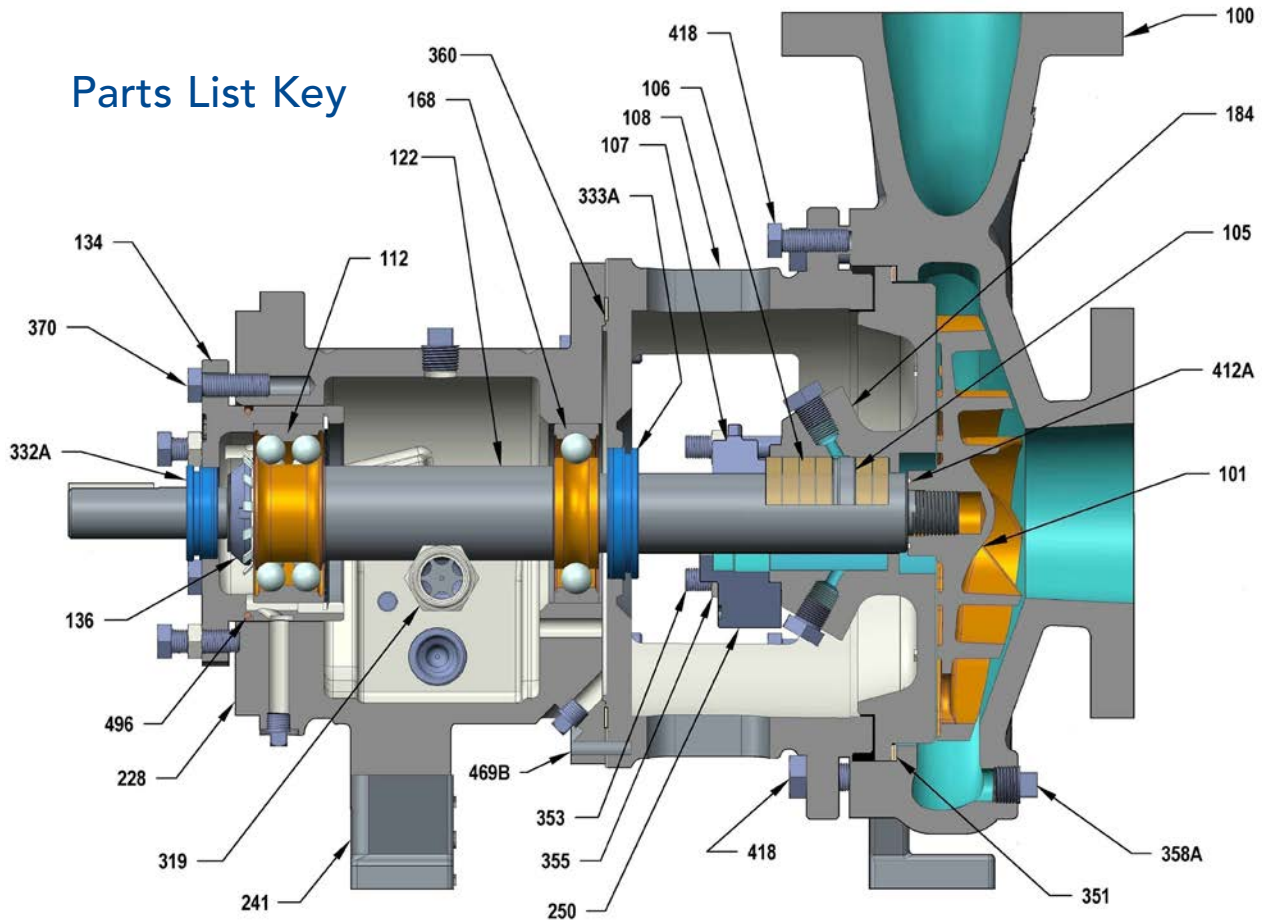

Parts List Key

Parts and Material Composition

ITEM NO.	REQ'D PER PUMP	PART NAME	ALL DUCTILE IRON	ALL 316SS	ALL ALLOY 20	ALL CD4MCuN
100	1	Casing	DI	316SS	Alloy 20	CD4MCuN
101	1	Impeller	DI	316SS	Alloy 20	CD4MCuN
105	1	Lantern Ring	Glass-Filled TFE			
106	1	Packing	SIL C-8201 Acid Rest.		TFE	
107	1	Packing Gland	316SS		Alloy 20	
108	1	Frame Adapter	Ductile Iron			
112	1	Outboard (Thrust) Bearing	Double-Row Angular Contact**			
122	1	Shaft - Less Sleeve (Optional - Shown)	316SS		Alloy 20	
122	1	Shaft - With Sleeve (Not Shown)	SAE4140			
126	1	Shaft Sleeve (Not Shown)	316SS		Alloy 20	
134	1	Bearing Housing	Cast Iron			
136	1	Lock Nut / Lock Washer	Steel			
168	1	Inboard (Radial) Bearing	Single-Row Deep Groove			
184	1	Stuffing Box	DI	316SS	Alloy 20	CD4MCuN
228	1	Frame	Cast Iron (Ductile for Small Frame)			
241	1	Frame Foot	Cast Iron			

ITEM NO.	REQ'D PER PUMP	PART NAME	ALL DUCTILE IRON	ALL 316SS	ALL ALLOY 20	ALL CD4MCuN
250	1	Mechanical Seal Gland	316SS		Alloy 20	
319	1	Sight-Oil Gauge	Cad. Plated			
332A	1	Labyrinth Oil Seal (Outboard)	Bronze (Optional Carbon Filled PTFE)			
333A	1	Labyrinth Oil Seal (Inboard)	Bronze (Optional Carbon-Filled PTFE)			
351	1	Casing Gasket	Aramid Fiber with EPDM Rubber			
353	4	Gland Stud	316SS			
355	4	Gland Nut	304SS			
358A	1	Casing Drain Plug	Steel	316SS	Alloy 20***	316SS***
360	1	Gasket, Frame-to-Adapter	Vellumoid			
360A	1	Gasket, Bearing-End Cover	Vellumoid (811XL Only)			
370	3	Bearing Housing Hex Bolt	Steel			
412A	1	Impeller O-Ring	Glass-Filled TFE			
418	3	Casing Jack Screw	Steel			
469B	2	Dowel Pin	Steel			
496	1	Bearing Housing O-Ring	Buna Rubber			

** 811L Power End features Duplex Angular Contact. Additional materials available upon request.
 *** Casing Drain Plug Optional

Component Interchangeability

Griswold 811 ANSI Series pumps are designed to be easy to maintain and repair. Many of the pump components can be interchanged between the models in order to maximize interchangeability within the portfolio to help simplify inventory and reduce costs.

Griswold Interchangeability Guide

Griswold 811 ANSI Series Pumps and Parts are interchangeable with *Goulds Pumps 3196 and other centrifugal pump models. For more information, visit our website to view our pump interchangeability guide.

SHAFT & BEARING FRAME	ADAPTER	STUFFING BOX	IMPELLER	CASING	CASING SIZE
Model 811S 1.375" shaft diameter max. BHP-40 @ 3600 RPM	●	●	●	●	1.5x1-6
					3x1.5-6
					3x2-6
					LF 1.5x1-8
					1.5x1-8
					3x1.5-8
					3x2-8
					4x3-8
					4x3-8G
					LF 2x1-10
Model 811M 1.75" shaft diameter max. BHP-122 @ 3600 RPM	●	●	●	●	2x1-10
					3x1.5-10
					3x2-10
					4x3-10
					6x4-10G
					6x4-10H
					3x1.5-13
					3x2-13
					4x3-13
					6x4-13
Model 811L 2.125" shaft diameter max. BHP-200 @ 3600 RPM	●	●	●	●	LF 2x1-10
					2x1-10
					3x1.5-10
					3x2-10
					4x3-10
					6x4-10G
					6x4-10H
					LF 3x1.5-13
					3x1.5-13
					3x2-13
4x3-13					
6x4-13					
Model 811XL 2.50" shaft diameter max. BHP-249 @ 1800 RPM	●	●	●	●	8x6-13
					10x8-13
					8x6-15
					10x8-15
Model 811XL17 2.50" shaft diameter max. BHP-350 @ 1800 RPM	●	●	●	●	10x8-15G
					4x3-17
					6x4-17
					8x6-17
					10x8-17
10x8-16H					

*Goulds Pumps is a registered trademark of ITT Corporation.

811 ANSI Series Dimensions

Small Pump End and Baseplate

PUMP-END DIMENSIONS (INCHES)										
	Pump Size	ANSI Designation	Discharge	Suction	D	X	CP	E1	E2	F
SMALL	1.5x1-6	AA	1.00	1.50	5.25	6.50	17.50	3.00	0	7.50
	3x1.5-6	AB	1.50	3.00	5.25	6.50	17.50	3.00	0	7.50
	3x2-6	AC	2.00	3.00	5.25	6.50	17.50	3.00	0	7.50
	1.5x1-8	AA	1.00	1.50	5.25	6.50	17.50	3.00	0	7.50
	LF1.5x1-8	AA	1.00	1.50	5.25	6.50	17.50	3.00	0	7.50
	3x1.5-8	AB	1.50	3.00	5.25	6.50	17.50	3.00	0	7.50

BASEPLATE DIMENSIONS (INCHES)											
Max NEMA Frame	Baseplate Number	HA Max	HB	HT Min	HD Max	HE	HF	HG Max	HH	HL	HP
184T	139	15.00	39.00	3.50	9.00	4.50	36.50	3.75	0.75	4.50	1.25
256T	148	18.00	48.00	3.50	10.50	6.00	45.50	4.13	0.75	4.50	1.25
326TS	153	21.00	53.00	3.50	12.88	7.50	50.50	4.75	0.75	4.50	1.25

Medium and Large Pump End and Baseplate

PUMP-END DIMENSIONS (INCHES)										
	Pump Size	ANSI Designation	Discharge	Suction	D	X	CP	E1	E2	F
MEDIUM	3x2-8	A60	2.00	3.00	8.25	9.50	23.50	4.875	3.625	12.50
	4x3-8	A70	3.00	4.00	8.25	11.00	23.50	4.875	3.625	12.50
	4x3-8G	A70	3.00	4.00	8.25	11.00	23.50	4.875	3.625	12.50
MEDIUM OR LARGE (LF 3x1.5-13 available with large frame only)	2x1-10	A05	1.00	2.00	8.25	8.50	23.50	4.875	3.625	12.50
	LF 2x1-10	A05	1.00	2.00	8.25	8.50	23.50	4.875	3.625	12.50
	3x1.5-10	A50	1.50	3.00	8.25	8.50	23.50	4.875	3.625	12.50
	3x2-10	A60	2.00	3.00	8.25	9.50	23.50	4.875	3.625	12.50
	4x3-10	A70	3.00	4.00	8.25	11.00	23.50	4.875	3.625	12.50
	6x4-10G	A80	4.00	6.00	10.00	13.50	23.50	4.875	3.625	12.50
	6x4-10H	A80	4.00	6.00	10.00	13.50	23.50	4.875	3.625	12.50
	3x1.5-13	A20	1.50	3.00	10.00	10.50	23.50	4.875	3.625	12.50
	*LF 3x1.5-13	A20	1.50	3.00	10.00	10.50	23.50	4.875	3.625	12.50
	3x2-13	A30	2.00	3.00	10.00	11.50	23.50	4.875	3.625	12.50
	4x3-13	A40	3.00	4.00	10.00	12.50	23.50	4.875	3.625	12.50
	6x4-13	A80	4.00	6.00	10.00	13.50	23.50	4.875	3.625	12.50

BASEPLATE DIMENSIONS (INCHES)												
Max NEMA Frame	Baseplate Number	HA Max	HB	HT Min	HD Max (IFD=8.25)	HD Max (IFD=10.00)	HE	HF	HG Max	HH	HL	HP
184T	245	15.00	45.00	3.50	12.00	13.75	4.50	42.50	3.75	0.75	4.50	1.25
215T	252	18.00	52.00	3.50	12.38	14.13	6.00	49.50	4.13	0.75	4.50	1.25
286T	258	21.00	58.00	3.50	13.00	14.75	7.50	55.50	4.75	1.00	4.50	1.25
365T	264	21.00	64.00	3.50	13.88	14.75	7.50	61.50	4.75	1.00	4.50	1.25
405TS	268	26.00	68.00	3.50	14.88	14.88	9.50	65.50	4.75	1.00	4.50	1.25
449TS	280	26.00	80.00	3.50	15.88	15.88	9.50	77.50	4.75	1.00	4.50	1.25

Note: Dimensions shown are based on the ASME (ANSI) B73.1 requirements. Contact the Griswold factory and/or distributor for exact construction dimensions.
 * Flange drilling is standard ANSI 150-lb, flat face. All LF pumps use 150-lb raised face flanges, except the LF 3x1.5-13, which uses 300-lb raised face flanges.

Extra Large Pump End and Baseplate

PUMP-END DIMENSIONS (INCHES)										
Pump Size	ANSI Designation	Discharge	Suction	D	X	CP	E1	E2	F	
X-LARGE	8x6-13	A90	6.00	8.00	14.50	16.00	33.875	8.00	4.50	18.75
	10x8-13	A100	8.00	10.00	14.50	18.00	33.875	8.00	4.50	18.75
	8x6-15	A110	6.00	8.00	14.50	18.00	33.875	8.00	4.50	18.75
	10x8-15	A120	8.00	10.00	14.50	19.00	33.875	8.00	4.50	18.75
	10x8-15G	A120	8.00	10.00	14.50	19.00	33.875	8.00	4.50	18.75
	4x3-17	-	3.00	4.00	14.50	16.00	33.875	8.00	4.50	18.75
	6x4-17	A105	4.00	6.00	14.50	16.00	33.875	8.00	4.50	18.75
	8x6-17	A110	6.00	8.00	14.50	18.00	33.875	8.00 <td 4.50	18.75	
	10x8-17	A120	8.00	10.00	14.50	19.00	33.875	8.00	4.50	18.75
10x8-16H	A120	8.00	10.00	14.50	19.00	33.875	8.00	4.50	18.75	

BASEPLATE DIMENSIONS (INCHES)											
Max NEMA Frame	Baseplate Number	HA Max	HB	HT Min	HD Max	HE	HF	HG Max	HH	HL	HP
286T	368	26.00	68.00	5.00	19.25	9.50	65.5	4.75	1.00	6.50	1.25
405T	380	26.00	80.00	5.00	19.25	9.50	77.5	4.75	1.00	6.50	1.25
449T	398	26.00	98.00	5.00	19.25	9.50	95.5	4.75	1.00	6.50	1.25

Note: Dimensions shown are based on the ASME B73.1 requirements. Contact the Griswold factory and/or distributor for exact construction dimensions.
 * Flange drilling is standard ANSI 150-lb, flat face. All LF pumps use 150-lb raised face flanges, except the LF 3x1.5-13, which uses 300-lb raised face flanges.

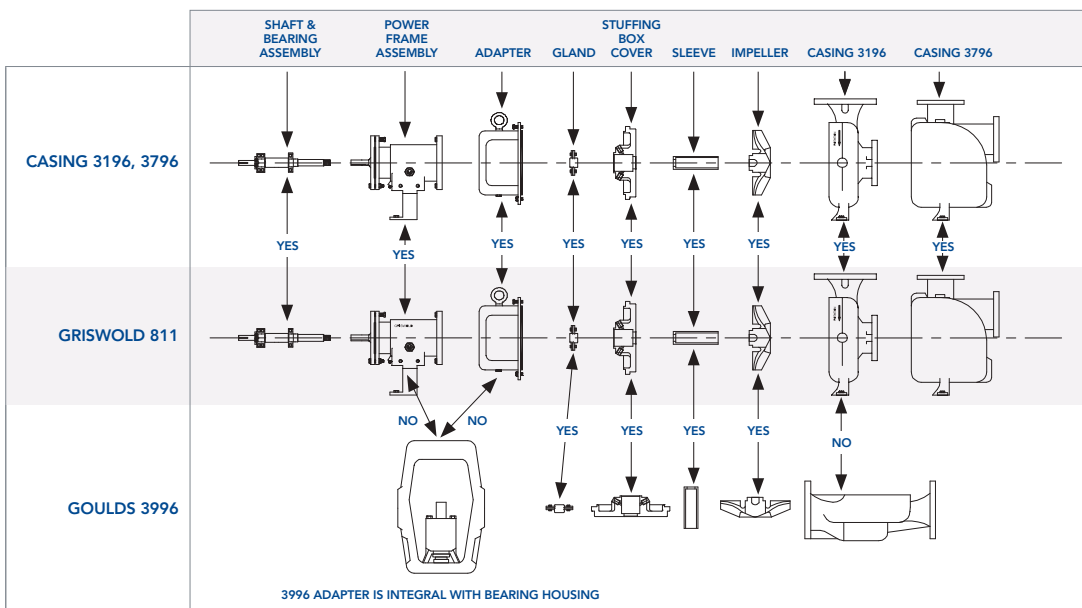
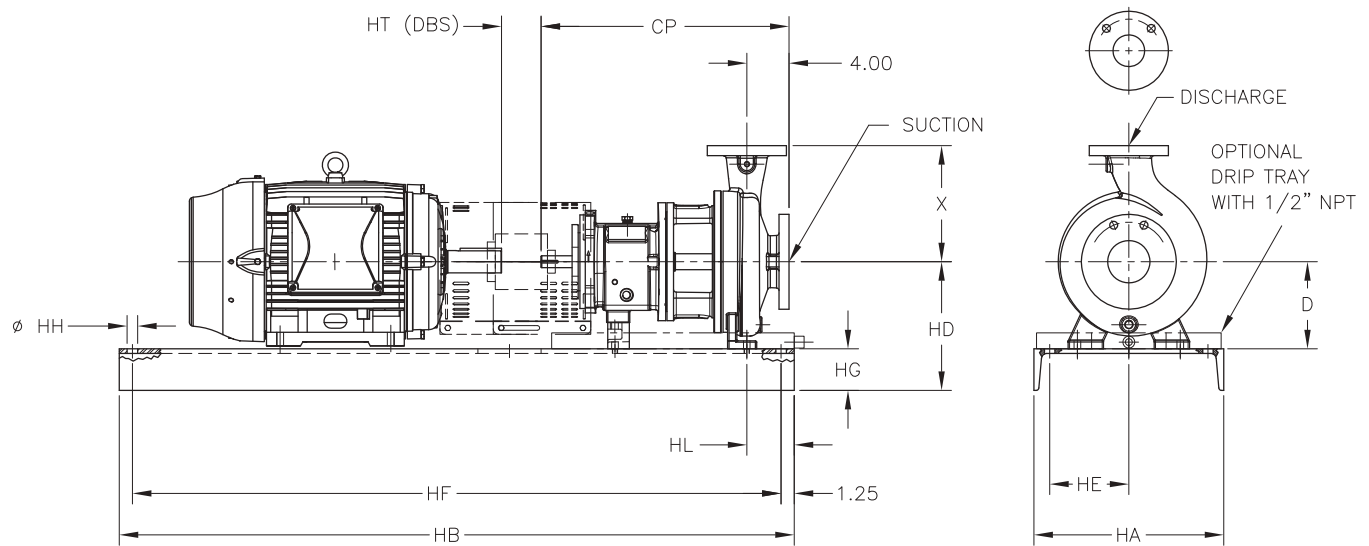

Griswold 811 ANSI Series Competitor Part-for-Part Interchangeability

Griswold 811 ANSI Series Pumps and Parts are interchangeable with Goulds Pumps 3196 and other centrifugal pump models.



PSG
22069 Van Buren Street
Grand Terrace
CA, 92313-5651
USA
P: +1 (909) 512-1262
F: +1 (909) 783-3440
griswoldpump.com



Where Innovation Flows

GRS-10000-C-13

Authorized PSG® Partner:

Copyright 2021 PSG®, a Dover company