



EDWARDS

MODEL 400 PUMP

FEATURES

The Edwards Series Model 400 Rotary Gear Pump has several unique features that make Edwards Series the right choice for many pumping requirements:

- Rotors synchronized by timing gears – they never touch
- Casing liners
- Shafts are supported on both ends by bearings – not bushings
- Pump drive flexibility – direct drive in most cases
- Inexpensive repairs
- Self priming
- Dry capability running
- Electric, diesel engine or water turbine drive

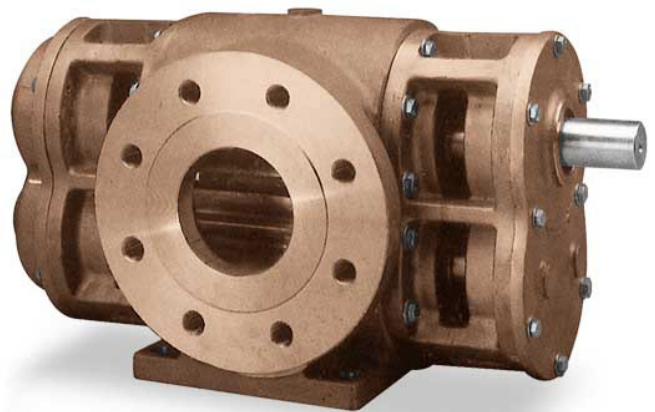

APPLICATIONS

FIRE PROTECTION

- Fire-fighting foam concentrate pumping
- Water mist pumps
- UL-listed/FM approved or non-listed applications
- Stationary or mobile systems

MODEL 400 PUMP SPECIFICATIONS

Materials of construction	Bronze
Options	Flanged connections, special mounting options
Sealing	Teflon lip seals
Temperature	200°F maximum
Discharge pressures	Up to 300 psig
Ports	4" x 4" 150# or 300# FLG
Pump drives	Hydraulic, electric, gas or diesel engine, PTO
RPM range	Up to 600rpm continuous Up to 1,800rpm intermittent

Edwards manufactures pumps to adapt to existing or new drive equipment. We custom build complete pumping packages. Our expertise includes complete assemblies with motors, engines, pumping skids and electrical apparatus with controls. Please feel free to contact us regarding your requirements.



WE'RE ALL ABOUT EXPERIENCE.

1300 255 786 | allpumps.com.au

DIMENSION DETAILS AND PERFORMANCE DATA MODEL 400 PUMP



APPROXIMATE OVERALL DIMENSIONS:

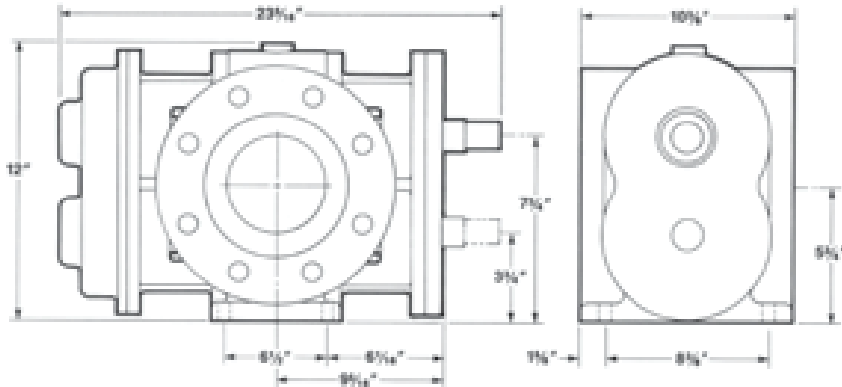

Average weight - Pump only: 350#

PERFORMANCE CHARACTERISTICS (standard duty):

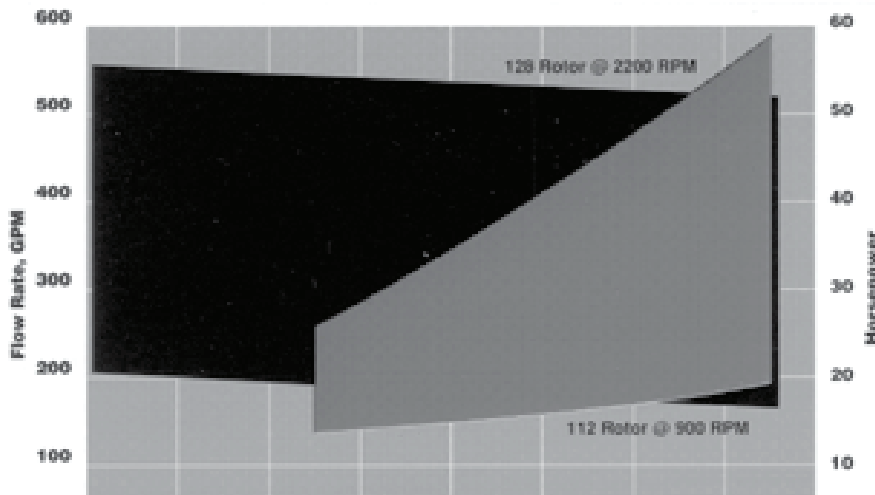

Other rotor sizes available



WE'RE ALL ABOUT EXPERIENCE.

1300 255 786 | allpumps.com.au