

Pump Series HP

CHARACTERISTICS

Packo rotary lobe pumps of the HP series are the robust and reliable beating hearts in the food industry. They offer maximum flexibility and adaptability to almost any requirement. Hygienically, they are state-of-the-art and comply with all the necessary regulations.

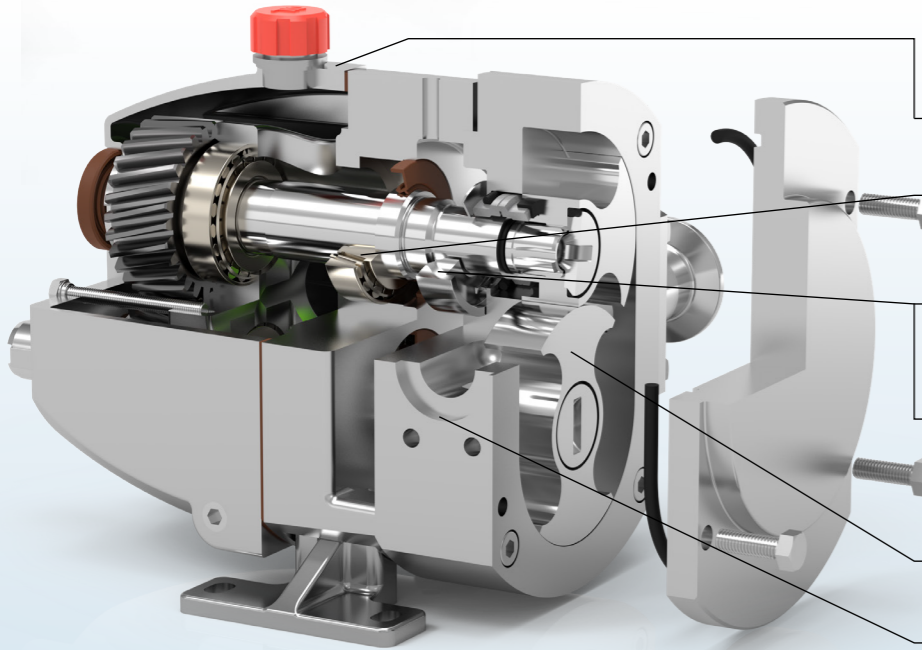
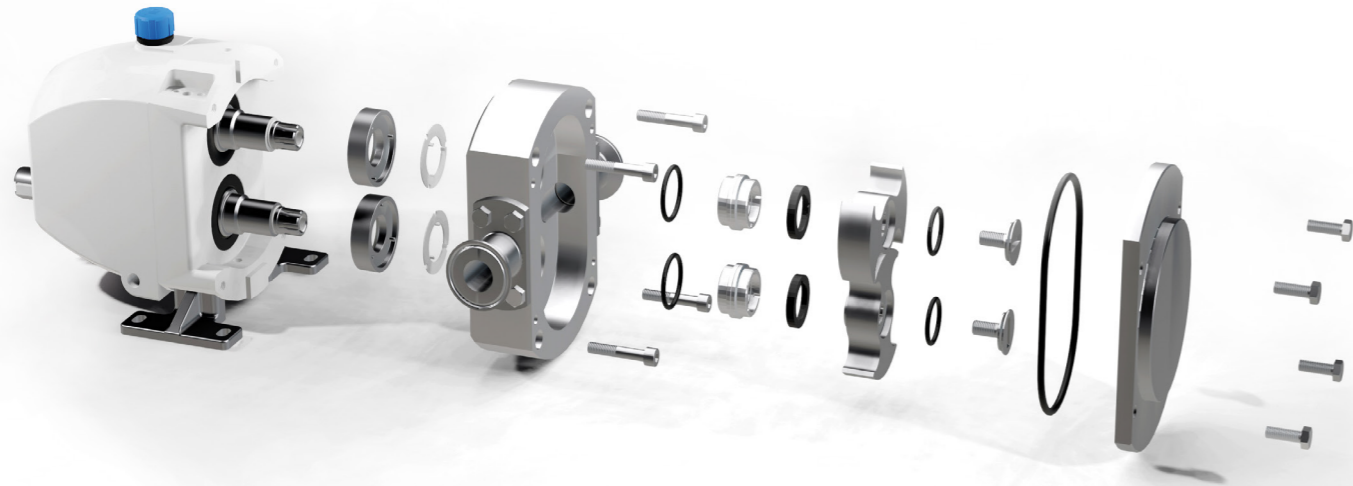

HP

- ① Epoxy coated lightweight aluminium gearbox and gearbox cover.
- ② Strong roller taper bearings and heavy duty shafts guarantee precise operation even under harsh conditions.
- ③ Different types of balanced mechanical seals, well positioned in the fluid stream provide save operation and good cleanability.
- ④ Wetted seal parts can be replaced without disassembling the rotor case: pump does not need to be mounted out of the installation to change seals.
- ⑤ Unique Scimitar and Tri lobe rotors allow efficient and smooth product handling.
- ⑥ Different hygienic port types, bolted for max. flexibility.

APPLICATION AREAS

HP series pumps look back to a long successful history in nearly all food and hygienic branches.

Due to their flexibility with detachable ports, various in type and size, as well as the various seal options they fit for use in industries like food, beverages, convenience, cosmetics, pharmaceuticals, pet food, sweets, chocolate and many more. They are known and loved for their reliability, long lasting design and at not at least for their easy and quick maintenance. The HP series is the solution for low to high viscous liquids, were smooth and gentle handling of the products is required.



YOUR BENEFITS

- Cleaner
 - Wetted surfaces with Ra < 0.8 µm.
 - Fully drainable designed pump casing.
 - Optimized design to eliminate dead-spaces, O-ring grooves without dead corners.
 - Wetted parts of mech. seal directly in the product stream.
 - Epoxy coated bearing housing has good corrosion resistance and smooth clean surface. Optional stainless steel bearing housing and gear cover gives total corrosion resistance and avoids paint chipping.
 - Materials certified to FDA, USP and EC1935/2004.
- Shorter downtimes
 - Faster maintenance.
 - Pump can stay in the system during replacing seals thanks to front loaded seals.
- Higher flexibility
 - Rotor change without timing.
 - Extended service intervals. The oil-lubricated gearbox avoids frequent relubrication of the bearings with grease. This reduces maintenance and increases operational reliability.
 - Bolt on ports allow quick adaptation to any pipe system reducing repair costs.
 - Heating jackets for casing and front cover, pressure relief valve and many more options available.
 - Pumps can be mounted with both horizontal and vertical port connections.
 - Short mounting dimensions also for narrow space conditions.

PUMP SERIES	HP
Performances	
Max flow rate	41 m³/h (higher capacity available with other pump series)
Max viscosity	1.000.000 cP
Max differential pressure	15 bar
Max temperature	140°C
Technical specifications	
Materials wetted parts	stainless steel 316L 1.4404
Seal configuration	single, flushed, double mechanical seal, gland packing
Available material O-ring	NBR, EPDM, FKM, PTFE
Connections	different bolted sanitary ports, rectangular inlet available
Mounting position	horizontal and vertical
Surface finish	food quality, internal surfaces Ra < 0,8
Certificates & legislation	

PUMP CURVES

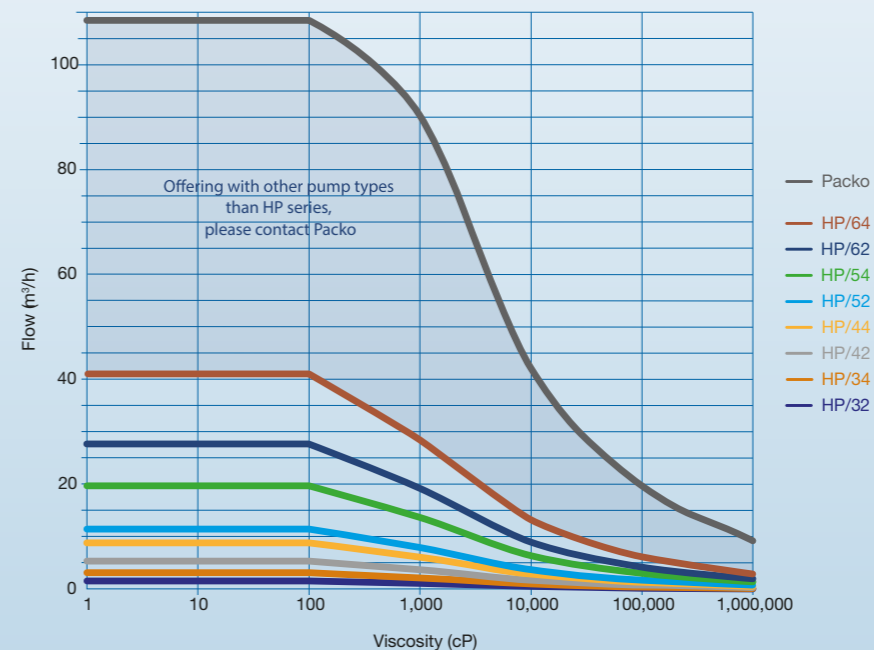

WE'RE ALL ABOUT EXPERIENCE.

Silverwater NSW 2128
 sales@allpumps.com.au
 1300 255 786
 www.allpumps.com.au