



WE'RE ALL ABOUT EXPERIENCE

allpumps.com.au

Durco® Mark 3™

ASME (ANSI) Chemical Process Pumps

Mark 3™ Standard | Sealmatic™ | Lo-Flo™
Recessed Impeller | Unitized Self-Primer



Experience In Motion



Durco Mark 3 – the premier name in ASME chemical process pumps

The Durco Mark 3 chemical process pump provides outstanding hydraulic performance, unrivaled reliability and low total cost of ownership. Conforming to ASME (ANSI) B73.1, it incorporates many proven reliability- and performance-enhancing features. The resultant benefits are:

- Renewable, high-efficiency performance over the life of the pump with the reverse vane impeller
- Optimal, predictable seal chamber pressures that are re-established after every impeller setting
- Maximal mechanical seal life due to an ideal seal environment created by the SealSentry™ seal chamber
- Robust shaft and bearing designs that minimize shaft deflection and extend mechanical seal and bearing life
- Fast and accurate impeller setting with the industry's most innovative external impeller adjustment mechanism
- In-shop reverse vane impeller adjustment with the only pump that takes full advantage of the back pullout design



Breadth of pumping solutions

Durco Mark 3 ASME (ANSI) chemical process pumps are available in a wide range of configurations to provide flexibility in countless applications throughout the worldwide infrastructure markets:

- Mechanically sealed
- Dynamically sealed
- Sealless, magnetic drive
- Low-flow
- Self-priming
- Recessed impeller

Typical applications

- Acid transfer
- Brine
- Chemical processing
- Petrochemical processing
- Corrosive services
- Food and beverage processing
- Hydrocarbon processing
- Pharmaceuticals

Table of contents

Durco Mark 3 ASME chemical process pumps	4 to 5
Performance curves	6
Interchangeability	7
Power ends	8 to 9
Shafts and bearings	10 to 11
SealSentry seal chambers	12 to 13
Impellers	14 to 15
RedRaven equipment monitoring and IoT solutions	16
Materials of construction	17
Options	18 to 19
Baseplates	20 to 22
Polyshield polymer baseplate and foundation system	23
Durco Mark 3 Lo-Flo pump	24 to 25
Durco Mark 3 Sealmatic pump	26 to 27
Durco Mark 3 Unitized Self-Priming pump	28 to 29
Durco Mark 3 Recessed Impeller pump	30 to 31
Durco Mark 3 pump family	32 to 33
Complementary pumps	34
Lifecycle cost solutions	35



Durco Mark 3 ASME chemical process pumps

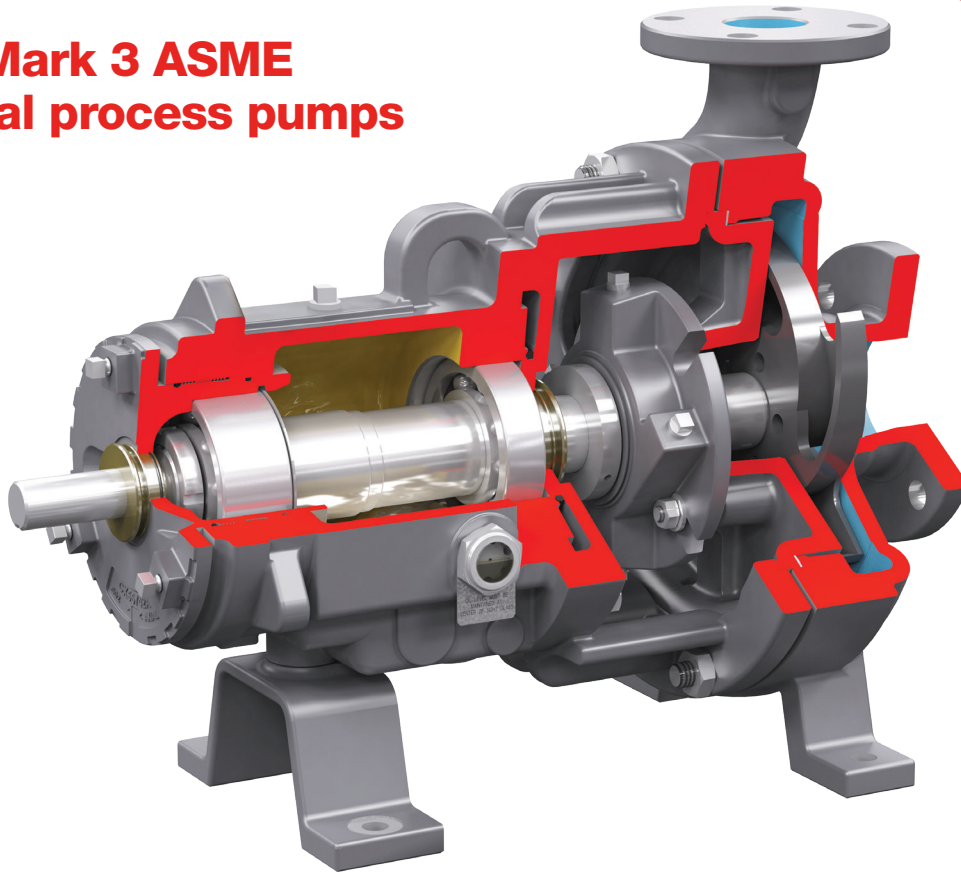

Conforming to ASME (ANSI) B73.1 and incorporating many advanced design features, the rugged Mark 3 pump provides unmatched performance and reliability while minimizing the total cost of ownership. It is CE marked and compliant with applicable directives such as ATEX.

Operating parameters¹

- Flows to 1,700 m³/h (7,500 US gpm)
- Heads to 300 m (990 ft)
- Pressures to 27 bar (400 psi)
- Temperatures from -73°C to 370°C (-100°F to 700°F)
- Discharge sizes from 25 to 200 mm (1 to 8 in.)

30 sizes available

- 7 Group 1
- 16 Group 2
- 7 Group 3

¹ Higher flow rates are available with the Durco Mark 3 Group 4 high-capacity process pump. See brochure PS-10-39 for details.

Features and benefits

Reverse vane impeller is the only impeller design that offers repeatable pump performance throughout the life of the pump. Open impellers are available.

SealSentry™ seal chambers with flow modifiers extend seal life and provide self-flushing capability.

External micrometer accurately sets impeller clearance in 20 seconds, whether in the shop or in the field.

Largest shaft and bearing components in standard ASME pumps reduce shaft deflection and vibration to extend bearing life and improve reliability.

Back pullout design allows removal of rotating element without removing casing, piping or motor.

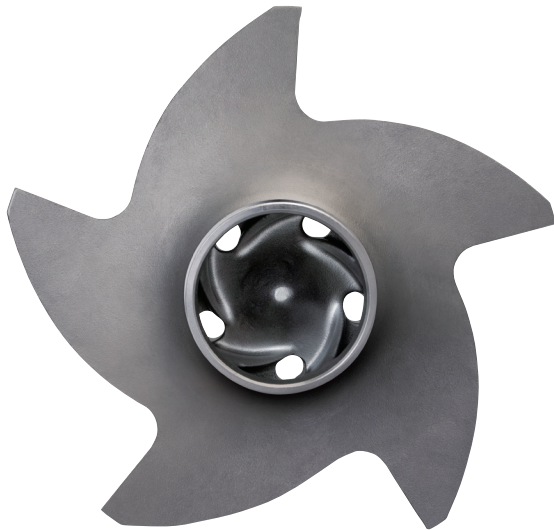

Reverse vane impeller lowers total cost of pump ownership

The Durco Mark 3 pump features a reverse vane impeller for unequalled efficiency and performance. This exclusive Durco design lowers pump ownership cost by easing maintenance and extending bearing and seal life.

- Low, predictable seal chamber pressure and thrust loads
- Lowest NPSHR of any ASME standard pump
- Abrasive wear is on the rear machinable cover, rather than the more expensive casing
- In-shop impeller adjustment with the only impeller that takes full advantage of the back pullout design
- Repeatable performance assurance

Truest running ASME (ANSI) pump

The Durco Mark 3 pump is engineered with four precision-machined, metal-to-metal fits to improve reliability.

- Reduce tolerance stack-ups on bearing carrier to improve shaft concentricity
- Superior to jackscrew designs, which can cause cocking
- Extend bearing and mechanical seal working life



SealSentry seal chamber technology helps the bottom line

The Durco Mark 3 pump incorporates SealSentry seal chambers with flow modifiers (FM) that reduce pump operating costs and increase pump availability by:

- Improving mechanical seal performance, reliability and life
- Reducing maintenance and repair costs
- Enabling the use of less costly seals and flush plans

Typical applications

- Acid transfer
- Caustic and chlor-alkali
- Man-made fibers
- Polymers
- Slurry processing
- Solvents
- Volatile organic compounds
- Waste processing



Performance curves²

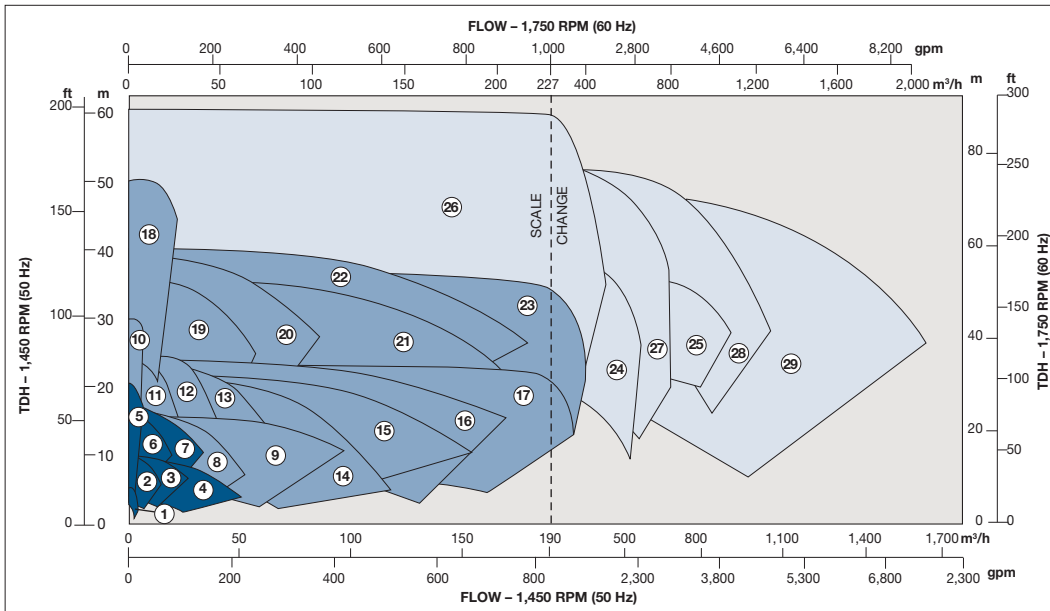
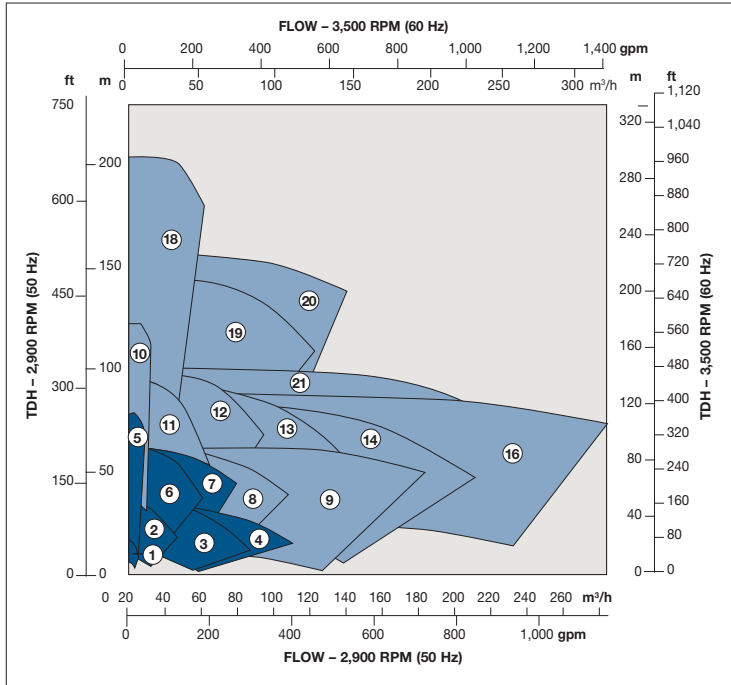

² Higher flows available with Durco Mark 3 Group 4 pump. Please see Bulletin PS-10-39 for more information.

³ Max. speed: 1,450 rpm

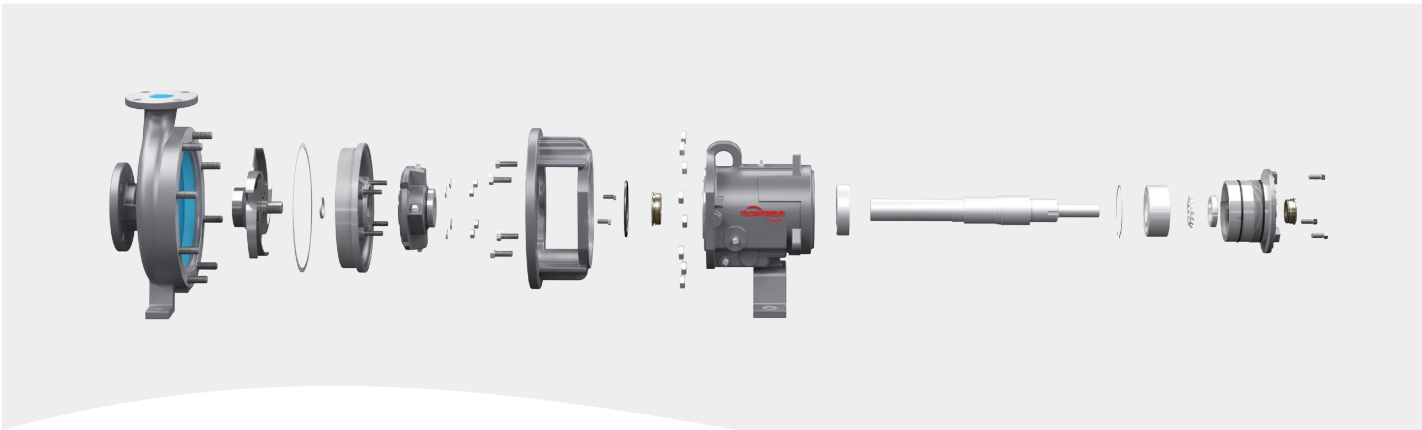

Interchangeability

With only three different power frames and five SealSentry seal chamber options, the 30 pumps in the Durco Mark 3 family offer a high degree of parts interchangeability. Pumps delivered worldwide are manufactured in ISO 9001 certified Flowserve facilities.



Quality System Certificate

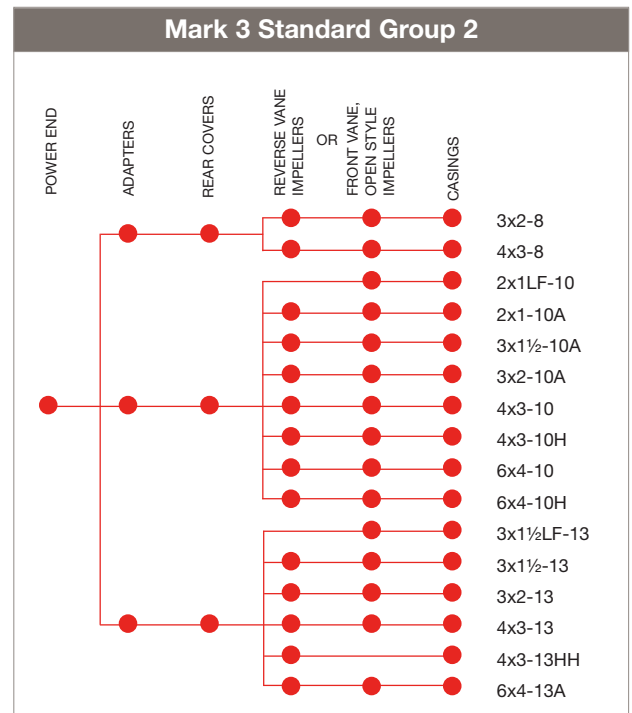
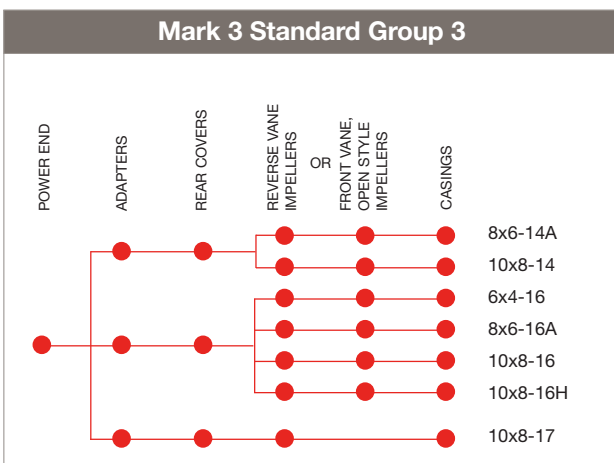
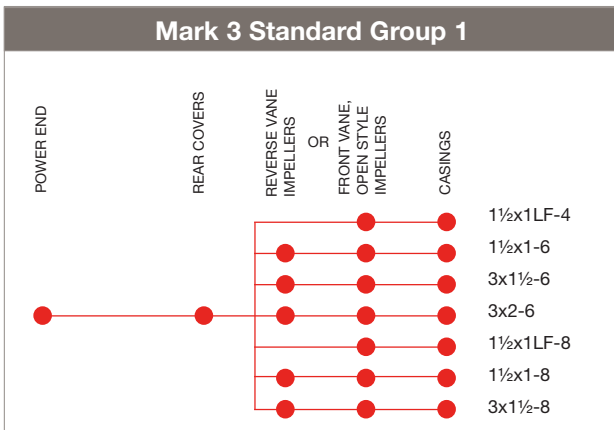



Power ends

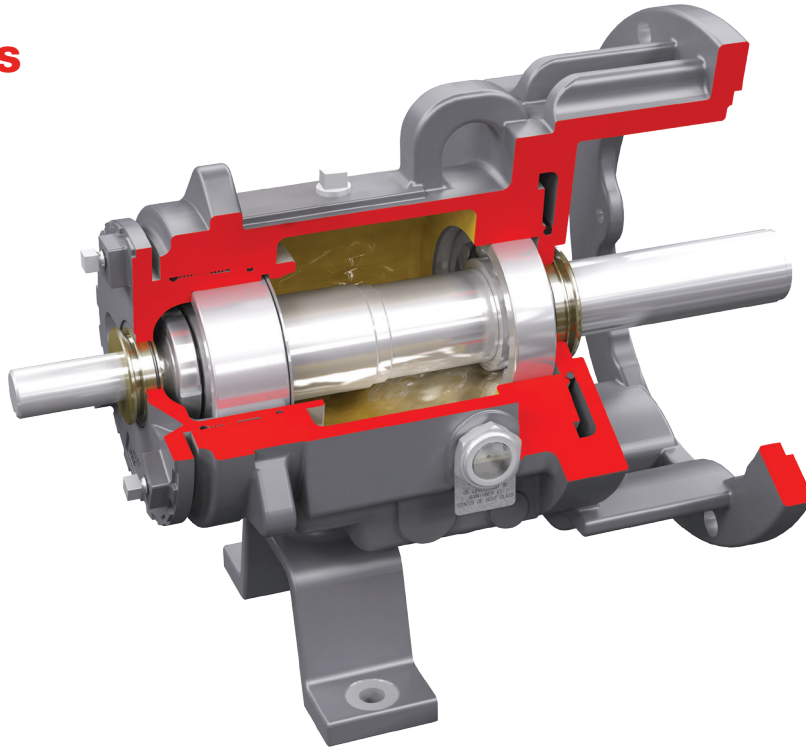

ANSI 3A power end

The Durco Mark 3 pump ASME product line features the ANSI 3A power end designed to improve reliability, maintenance and performance. It conforms with the ASME B73.1 standard and is so advanced it carries a lifetime warranty.⁴

Features include:

- Certified clean room assembly
- External micrometer easily restores pump efficiency.
- Flowserve Bearing Gard bearing isolators; Inpro/Seal® VBXX isolators optional
- Double-row, angular contact outboard and single-row, deep groove inboard bearings provide excellent axial and radial load support.
- Compatible with RedRaven equipment monitoring and IoT solutions
- Metal-to-metal fits assure a true running and concentric shaft that extends bearing and seal life.
- 0.4 micron (16 µin.) on critical shaft surfaces ensures secondary sealing ability of mechanical seals.
- Magnetic drain plug
- Rigid foot design

Mark 3A pump power end

Where ASME B73.1 compliance is not required, the Mark 3A power end may be used.

This design provides options for:

- Trico WATCHDOG constant level oiler with integral viewpoint
- Double-lip oil seals
- Top-mounted vent and oil filler

Lubrication options include:

- Oil bath
- Oil mist systems
- Grease
- Shielded grease

⁴ Note: Adherence to proper installation, operation and maintenance procedures is necessary for lifetime warranty. Contact your Flowserve representative for detailed terms and conditions.

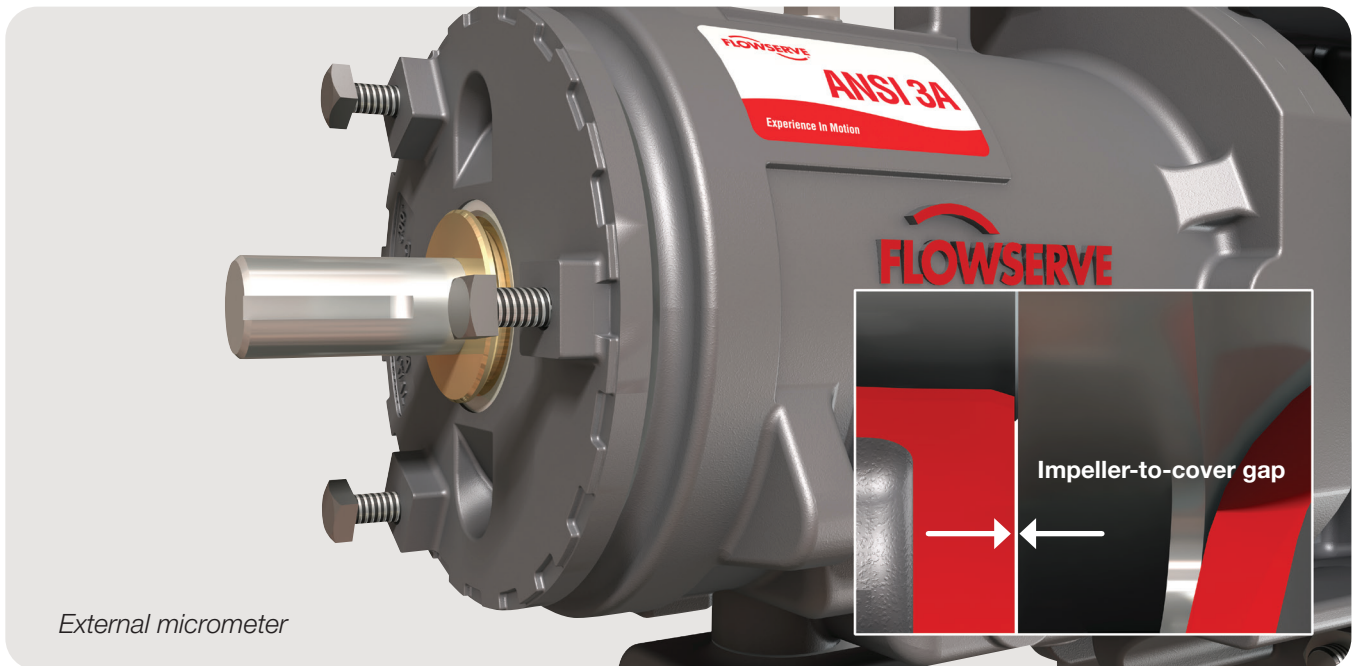

External micrometer

External micrometer reduces maintenance time and costs

The innovative Durco external micrometer impeller adjustment mechanism is simple to use, saving time and money. Superior to jackscrews, it accurately sets reverse vane impeller clearance in 20 seconds, in the shop or the field.



Step 1: Loosen the setscrews. Using a wrench, rotate the bearing carrier counterclockwise until the reverse vane impeller lightly touches the rear cover plate.

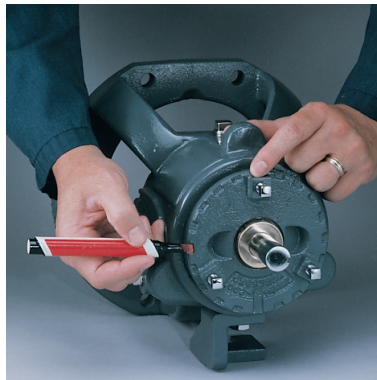

Step 2: Select the impeller setting. Each notch on the carrier ring represents exactly 0.10 mm (0.004 in.) of clearance. For an impeller setting of 0.5 mm (0.020 in.), count five notches counterclockwise.



Step 3: Move the carrier clockwise the selected number of notches. Tighten the setscrews and check the impeller clearance with the feeler gauge.

Shafts and bearings⁵

Shaft and sleeve options

Durco Mark 3 shafts and sleeves are designed to improve pump reliability and performance. They are available in numerous materials to suit application needs.

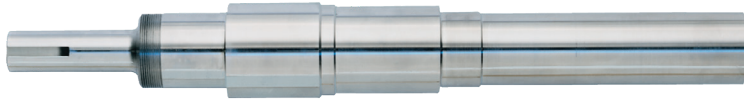

Friction-welded: a steel power end friction-welded to a solid alloy wet end



Composite: a steel shaft end-to-end with an integral (i.e., not replaceable) sleeve of DC8, SD77 high silicon iron, ceramic (alumina or zirconia)



Solid: end-to-end solid steel or stainless alloy



Hook sleeve: shaft is end-to-end solid steel or steel power end friction-welded to a stainless alloy wet end; either accommodates a hook sleeve

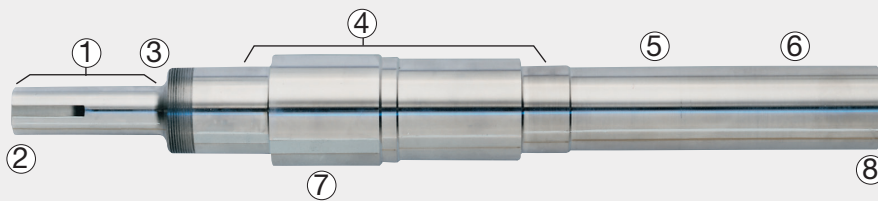

- ① Offset keyways aid shaft balance.
- ② Alloy identification ensures the right parts go in every time.
- ③ Large radii fillets add strength.
- ④ Accurate machining ensures perfect bearing fits without vibration or hot running.
- ⑤ Run-out of 0.03 mm (<0.001 in.) allows seal faces to run true.
- ⑥ Critical surfaces ground to a surface finish of 0.4 micron (16 µin) ensure the secondary sealing ability of mechanical seals.
- ⑦ Steel power ends handle higher horsepower loads than stainless.
- ⑧ Minimally radiused edges ensure full contact with impeller for reduced run-out.

⁵ Flowserve recommends the use of solid shafts rather than shaft sleeves to reduce the harmful effects of deflection and vibration. Shaft sleeves may simplify maintenance, but solid shafts reduce it.

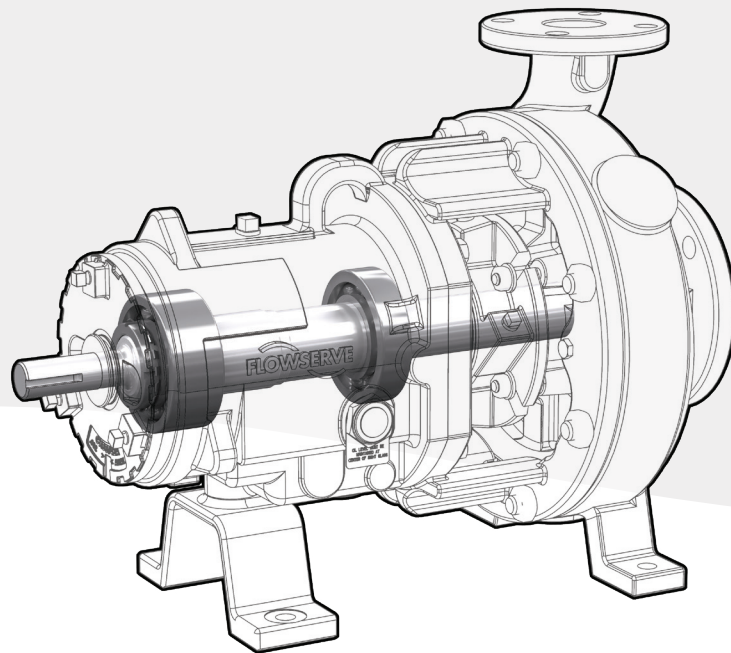

Unrivaled shaft and bearing design

With the largest shaft and bearing components available for ASME (ANSI) standard pumps, the Durco Mark 3 shaft and bearings system improves pump performance and reliability. A comparison of the Durco Mark 3 Group 2 power end with that of a major competitor demonstrates the benefits of its heavy-duty design.

Bearings

The dynamic load rating for the Durco Mark 3 pump is indicated in Table 1. A greater dynamic load rating translates into extended bearing life. A comparison reveals Durco Mark 3 bearings are designed to last up to 61% longer than that of a major competitor.

Shaft

The deflection index⁶ provides an approximate comparison of shaft stiffness. The lower the value, the better a shaft's ability to resist deflection. Durco Mark 3 shafts provide 43% to 252% greater stiffness. This results in superior pump performance and reliability. (See Table 2.)

⁶ The deflection index formula is $I = L^3/D^4$ where: I = index of deflection; L = length of shaft overhang from bearing; and D = rigid shaft diameter. While this index can provide an approximate comparison of shaft stiffness, a detailed analysis should be made to determine actual shaft deflection.

Table 1: Bearing comparison

Group 2	I.B. Bearing	Dynamic Load Rating	O.B. Bearing	Dynamic Load Rating
Flowserve	6,310	6,078 kg (13,400 lb)	5,310	8,709 kg (19,200 lb)
Major Competitor	6,309	5,398 kg (11,900 lb)	5,309	7,439 kg (16,400 lb)

Extended Bearing Life Comparison I.B. = $\left| \frac{6,078}{5,398} \right|^3 = 1.43^{(+43\%)} \quad \text{O.B.} = \left| \frac{8,709}{7,439} \right|^3 = 1.61^{(+61\%)}$

Table 2: Deflection comparison

Group 2	Overhang Length	Solid Shaft		Sleeve	
		Shaft Diameter	Deflection Index	Shaft Diameter	Deflection Index
Flowserve	189 mm (7.687 in.)	48 mm (1.875 in.)	37	38 mm (1.5 in.)	90
Major Competitor	213 mm (8.375 in.)	45 mm (1.75 in.)	63	38 mm (1.5 in.)	116

SealSentry seal chambers

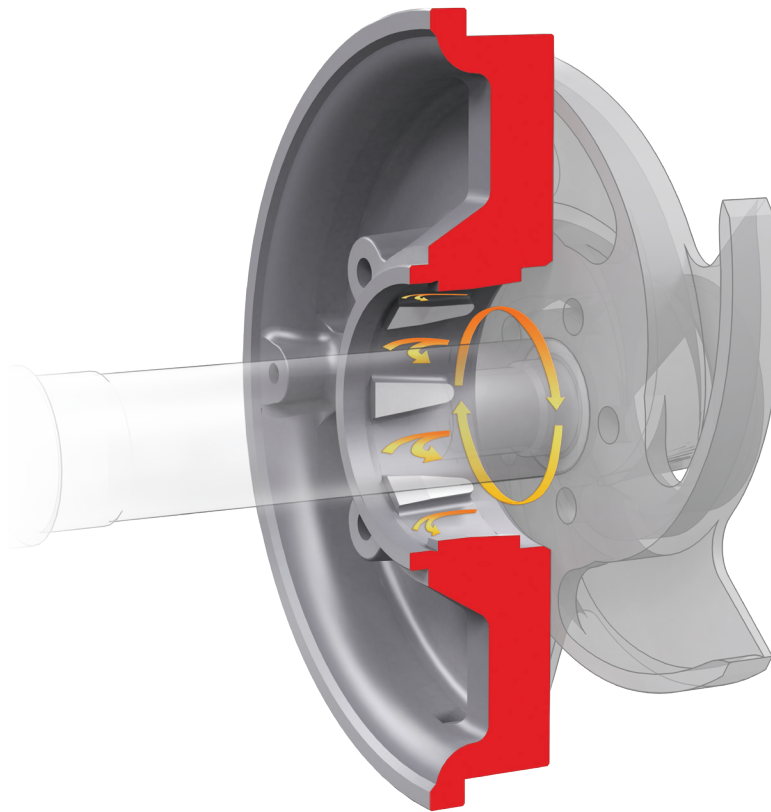

Advanced seal chamber technology

An integral part of the rear cover, Durco SealSentry seal chambers extend seal life, improve pump reliability, and reduce the total cost of pump ownership:

- Provide optimal seal chamber environment
- Extend mechanical seal life
 - Self-flushing
 - Self-venting
 - Self-draining
- Reduce maintenance and repair costs
- Permit use of less expensive seals and flush plans; plans 11, 32, 52, 53, etc. can be eliminated
- Provide a safer environment for personnel

Flow modifiers extend seal life

- Flow modifiers redirect flow from circumferential to axial.
- Balanced flow with low-pressure drop in the chamber helps keep solids in suspension, minimizing erosion.
- The mechanical seal creates a centrifuging action away from its parts.
- Solids and slurry merge into the returning flow path and are flushed out of the seal chamber.

Jacketed rear covers available

Jacketed versions of Durco rear covers with SealSentry seal chambers are available. Flowserve engineers will help you select the right jacketed cover for your application.

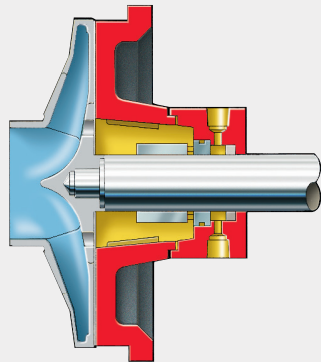

FML

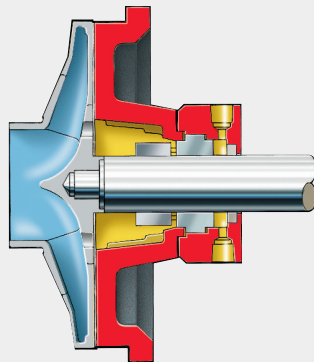

FMS

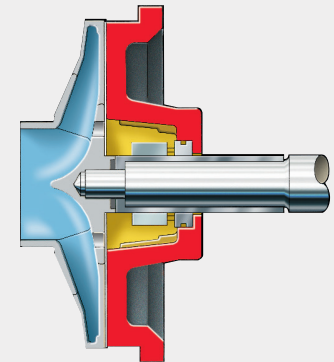

FMI

Flow modifier designs

FML — Large taper bore design with a large gland bolt and gasket circle, the FML is the most versatile and preferred for many applications:

- Single cartridge and component seal arrangement
- Dual cartridge and component seal arrangements

FMS — Small taper bore design with a small gland bolt and gasket circle, the FMS is ideal for single cartridge and component seal arrangements.

FMI — Small taper bore design which incorporates an integral cast-in gland for use with single internal component seal arrangements. Typically used in sanitary-type applications.

Cylindrical bore designs

CBL — Large oversized cylindrical bore design with a large gland bolt and gasket circle. It may be used with:

- Single-cartridge and component seal arrangement
- Dual-cartridge and component seal arrangements
- Typically used with a flush plan system
- Optional carbon bushing for use in process isolation, cooling or seal chamber pressure boost applications

CBS — Small cylindrical bore design with a small gland bolt and gasket circle. It may be used with:

- Single-cartridge and component seal arrangement
- Typically used with a flush plan system
- Can be used with packing arrangements

SealSentry nomenclature

FML	Large taper bore design with flow modifiers
FMS	Small taper bore design with flow modifiers
FMI	Small taper bore design with flow modifiers and integral cast gland
CBL	Large cylindrical bore design with optional carbon bushing
CBS	Small cylindrical bore design

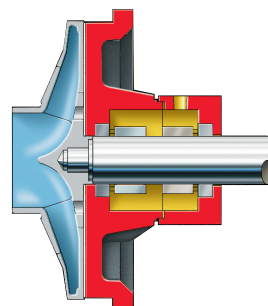

CBL

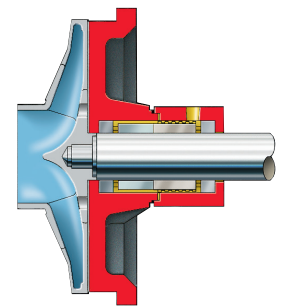

CBS

Impellers



Exclusive reverse vane impeller offers performance and maintenance advantages

The Durco reverse vane impeller with balance holes delivers excellent efficiency and performance, while extending bearing and seal life. The result is reduced total cost of pump ownership.

- **Low predictable seal chamber pressure and thrust loads** mean seals last longer.
- **Lowest required NPSH** of any standard pump.
- **Machinable rear cover face** takes the abrasive wear instead of the more expensive casing, so replacement parts are less costly.
- **Easy impeller clearance setting** with the only impeller design that takes full advantage of the back pullout feature. Clearance is set against the rear cover and is as easily done in the shop as in the field.
- **Dependable performance** with the only impeller design that offers repeatable seal chamber pressures and bearing thrust loads.

Optional impeller designs

The Durco Mark 3 pump is also available with a front vane, open impeller. Fully interchangeable with the reverse vane impeller, the open impeller is an excellent choice for fibrous, stringy materials and certain applications requiring high shear against the casing.

Low-flow and recessed impeller pump configurations are also available. See pages 24 and 30, respectively.



Reverse vane impeller adjustment

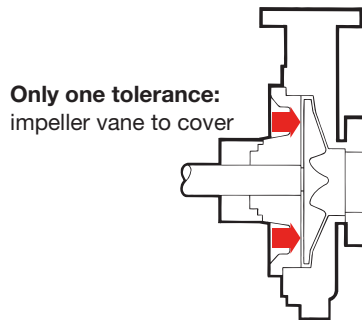

Front vane impeller adjustment

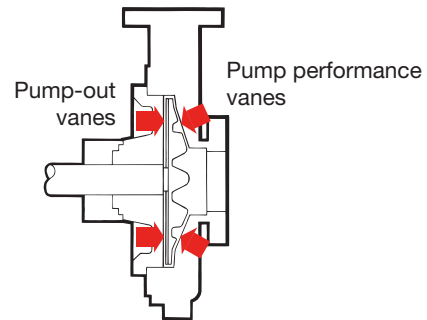

Predictable, repeatable performance

The Durco reverse vane impeller offers like-new performance each time it is adjusted.

Reverse vane impellers

A reverse vane impeller has only one set of pumping vanes and one critical tolerance. This single tolerance — between the impeller and the rear cover — establishes:

- Performance
- Efficiency
- Seal chamber pressure
- Thrust loads

Wear causes axial thrust loads to decrease as the seal chamber gap widens. At the same time, seal chamber pressure increases. By adjusting the setting of the reverse vane impeller against its single tolerance location, the original seal chamber pressure and axial thrust loads are re-established. The result is consistent, like-new performance.

Open style impeller

An open impeller has two sets of pumping vanes and two critical tolerance locations.

The front vane clearance to the casing establishes:

- Performance
- Efficiency

The back pump-out vane clearance to the rear cover establishes:

- Seal chamber pressures and seal life
- Thrust loads and bearing life

Wear causes axial thrust loads and seal chamber pressure to increase as the seal chamber gap widens, but the impeller cannot be adjusted to both tolerance locations at the same time. Seal chamber pressure and bearing loads increase after each adjustment. Performance is diminished, and seal and bearing life suffers as a result.

Effects of wear and impeller readjustment

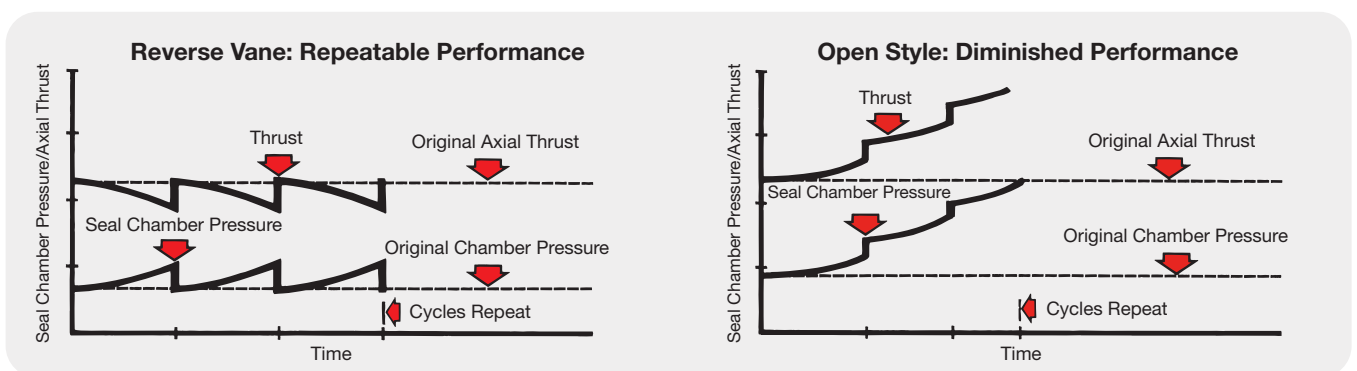

RedRaven equipment monitoring and IoT solutions

Durco Mark 3 ANSI pumps are compatible with advanced internet of things (IoT) solutions such as RedRaven from Flowserve. Flowserve RedRaven IoT solutions give you the insights and tools you need to monitor, analyze and predict equipment performance — so you can respond to problems quickly and minimize disruptions and downtime. And because RedRaven solutions are scalable, they will grow with your needs.

The RedRaven platform comprises a suite of technologies and service offerings that can be customized to meet your plant's unique needs.



Wireless condition monitoring

Flowserve pumps can be supplied with the Node ER sensor to provide near real-time condition monitoring. Node ER sensors collect a variety of parameters, including three-axis vibration, temperature and pressure every 30 minutes with a wireless range of up to 1 mile in industrial environments.



Predictive analytics

Flowserve pumps can be supplied with Detect sensors wired to a Data Transfer Box to measure velocity vibration data in accordance with DIN/ISO 20816 every 30 seconds. Collected data is used to run predictive analytics that provide early warning of equipment issues before they cause a failure.



RedRaven Insight portal

Both condition monitoring and predictive analytics readings are shown in the RedRaven Insight portal. The web-based portal allows users to view their data from anywhere and set custom alerts to watch over equipment 24/7. Users also get the peace of mind that the Flowserve Monitoring Center is looking out for alerts and providing recommendations to improve uptime.

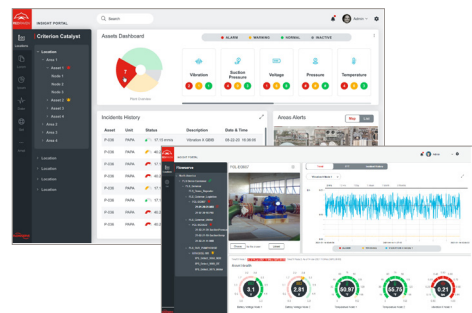



Materials of construction

All Durco Mark 3 wet-end castings carry a limited lifetime guarantee.

Standard materials of construction⁷

Designation	Symbol	ACI Designation	Equivalent Wrought Designation	ASTM Specifications
Ductile iron	DCI	None	None	A395, Gr. 60-40-18
Carbon steel	DS	None	Carbon steel	A216 Gr. WCB
CF-8M	D4	CF8M	316	A744, Gr. CF8M
CF-3M	D4L	CF3M	316L	A744, Gr. CF3M
Durcomet™ 100	CD4M	CD4MCuN	Ferralium 255	A995, Gr. 1B
Super Duplex (5A)	5A	CE3MN	2507	A890 Gr. 5A
Super Duplex (6A)	6A	CD3MWCuN	Zeron 100	A890 Gr. 6A
Durimet 20	D20	CN7M	Alloy 20	A744, Gr. CN7M
Chlorimet 2	DC2	N7M	Alloy B-2	A494, Gr. N7M
Chlorimet 3	DC3	CW6M	Alloy C-276	A494, Gr. CW6M
Titanium	Ti	None	Titanium, Grade 3	B367, Gr. C-3
Titanium-Pd	Ti-Pd	None	Titanium, Grade 7 or 8	B367, Gr. C-8A
Monel	DM	M35-1	Monel 400	A494, Gr. M35-1
Nickel	DNI	CZ100	Nickel 200	A494, Gr. CZ100
Durcomet 5	DV	None	Antimit A611	None
CY-40	DINC	CY40	Inconel 600	A494, Gr. CY40
Superchlor®	SD77	None	None	None
DC-8	DC8	None	None	None
Zirconium	Zr	None	Zirconium	B752, Gr. 705C

⁷ Alloys conform to the chemical and mechanical requirements of the latest edition of the ASTM specification.

Options

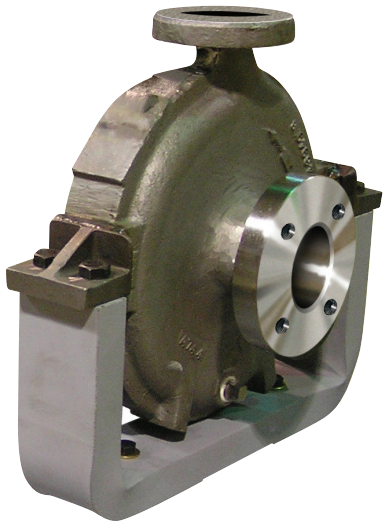

Centerline mounted casing

The Durco Mark 3 pump may be configured with a centerline mounted casing to reduce loads caused by thermal expansion. Optional jacketed feet with inlet and outlet ports further ensure effective temperature control.



Jacketed casings and rear covers

Jacketed casings and covers are available with the Mark 3 pump to provide temperature control. Two casing designs are available: integral (shown) and bolt-on jackets. All rear covers are available with integral jackets.

Ultralign™ heavy-duty, rigid design C-flange adapter

- Cantilevered motor shaft stays aligned with pump shaft, even with undesirable movement caused by piping and temperature-induced stress.
- Eliminates foot mounting of motor and pump power end to the base, reducing soft foot, twisting and diaphragming problems.
- 0.18 mm (0.007 in.) nominal parallel shaft alignment; 0.05 mm (0.002 in.) with C-Plus Four Point precision alignment option
- <0.025 mm/mm (0.001 in./in.) angular alignment
- The unique C-Plus Four Point Precision Alignment System enables installation and maintenance personnel to align shafts within 0.05 mm (0.002 in.) in fewer than 30 minutes.
- Adjustable rigid foot mount is designed to support all normal loads and ensures accurate alignment to the baseplate and piping.

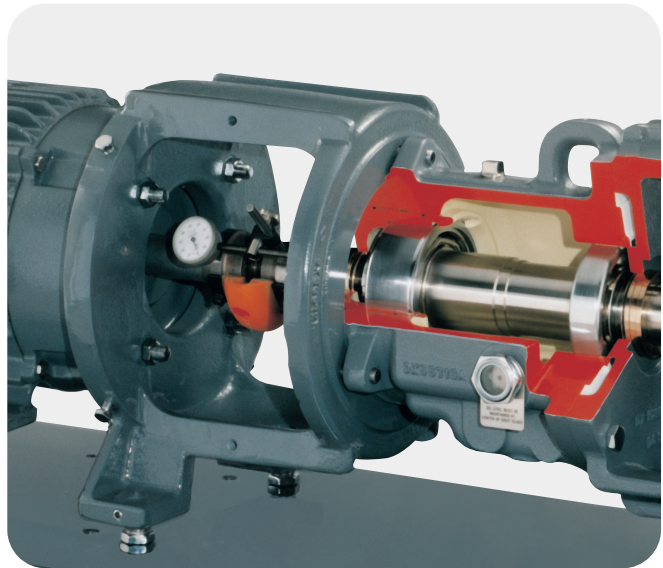



ClearGuard and DurcoShield non-metallic safety guards

ClearGuard and DurcoShield pump guards permit visual inspection of coupling and seal areas, respectively, while protecting personnel from potential safety hazards of rotating parts. Constructed of tough, durable and transparent polycarbonate with UV light inhibitors, they are designed to withstand tough chemical processing environments.

ClearGuard non-metallic coupling guard

The ClearGuard non-metallic coupling guard meets machinery guard safety guidelines. Nothing larger than 6 mm (0.24 in.) in diameter can enter the shell. Furthermore, the ability to inspect the coupling through ClearGuard can provide early warning of deteriorating or malfunctioning components.

DurcoShield[®] splash and shaft guard

The DurcoShield splash and shaft guard is a one-piece shield that envelops the open areas between the bearing housing and casing. Suitable for applications to 150°C (300°F), DurcoShield protects users from:

- Process fluid spray
- Rotating shaft and seal components

Available stilt-mounted baseplate

A stilt-mounted baseplate provides relief of external pipe loads by allowing the assembly to move to the point of least resistance.

- Standard stilts can allow for improved pump alignment to process pipe.
- Spring-loaded stilts absorb vibration and reduce the need for pipe loops or expansion joints.

⁸ DurcoShield is neither a containment system nor a seal backup system. It is a limited protection device. It will reduce, but not eliminate, the probability of injury.



Baseplates

Five pre-engineered baseplate designs extend pump and seal life

Flowserve offers five pre-engineered baseplate designs to improve pump performance and reliability while reducing ownership costs. Pump and seal life are extended by reducing internal pump stress and vibrations. Each is designed to:

- Provide torsional lateral and longitudinal rigidity
- Improve vibration dampening
- Protect against transit damage
- Resist twisting during installation
- Maintain shaft alignment
- Reduce installation and shaft alignment times.
- Reduce diaphragming or separation from grout
- Improve pump, motor and seal reliability
- Reduce total lifecycle pump, motor and seal costs

Item No.	Standard Options	Type A		Type B	Type C	Type D	Type D w/Rim	Type E
		Gp 1 & 2	Gp 3					
1	Machined coplanar mounting surfaces to 0.17 mm/m (0.002 in./ft) with 3.2 micron (125 µin.) finish	O	O	O*	O	O	O	Y
2	Added structural (cross-member) support	N	N	Y	Y	Y	Y	Y
3	Added torsional support with end caps	NR	Y	Y	D	O	O	Y
4	Tapped holes for four (4) motor adjuster bolts	O	O	NA	O	O	O	Y
5	Four (4) — SS transverse jack bolts — motor adjusters	O	O	NA	O	O	O	Y
6	Sloped surface to an integral drain	N	N	C	N	N	N	Y
7	Integral sloped drip rim around base	N	N	N	N	N	Y	Y
8	102 mm (4 in.) diameter grout holes — max. 762 mm (30 in.) run to vent	Y	Y	Y	N	Y	Y	Y
9	13 mm (0.5 in.) vent holes at corner of each chamber	NR	O	NR	NA	Y	Y	Y
10	Lower surface shaped to anchor in grout	N	N	N	NA	Y	Y	Y
11	Integral lifting eyes at four (4) corners	O	Y	N	O	Y	Y	Y
12	Tapped leveling holes at four (4) corners	Y	O	Y	S	Y	Y	Y
13	Continuous seam weld construction	NA	Y	NA	O	Y	Y	Y
14	Welded raised lip around grout hole(s)	NR	NR	NA	NA	NR	NR	Y
15	Stilt-mounting options with floor cups	NR	NA	O	Y	D	D	NA
16	Spring-mounted load designs	NA	NA	O	O	D	D	NA
17	Catch basin (304 stainless steel or other materials)	O	O	NA	O	O	NR	NA
18	Option for eight (8) total motor adjusters	O	O	O	O	O	O	Y
19	Dimensions to ASME B73.1	Y	Y	Y	Y	Y	Y	Y

Y = Standard N = Not available NR = Not recommended D = Needs design time
 O = Optional NA = Not applicable C = Sloped catch basin with 25 mm (1 in.) drain (option) S = Stilts for leveling

See page 21 for model descriptions.

*Coplanar to 0.42 mm/m (0.005 in./ft)

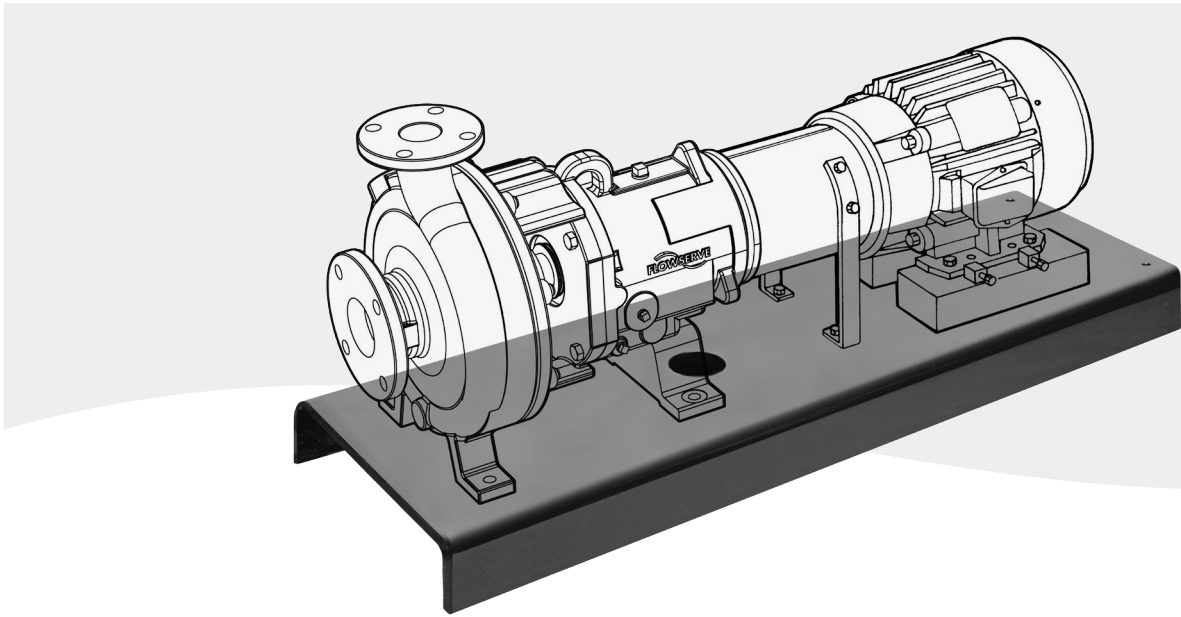

Type A
Standard ASME (ANSI) baseplate;
foundation mounted

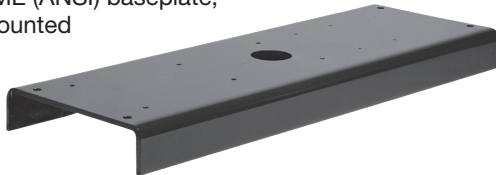

Type B
Polybase™; foundation
or stilt mounted

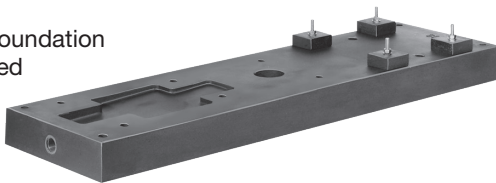

Type C
Reinforced; stilt mounted



Type D
Reinforced; foundation
mounted; drip
rim optional



Type E
Heavy-duty, foundation
mounted; complies
with PIP
RESP 002

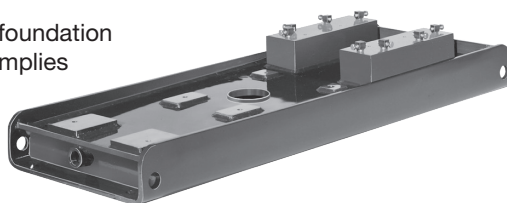

Rigid construction

Metal baseplate sizes:

- 139 to 258 feature 12 mm (½ in.) steel plate
- 264 to 280 feature 16 mm (⅝ in.) steel plate
- 368 to 398 feature 19 mm (¾ in.) steel plate

Polybase baseplates are constructed of 76 to 102 mm (3 to 4 in.) solid polymer concrete.

Types B, C, D and E are reinforced with added structural support for improved rigidity.

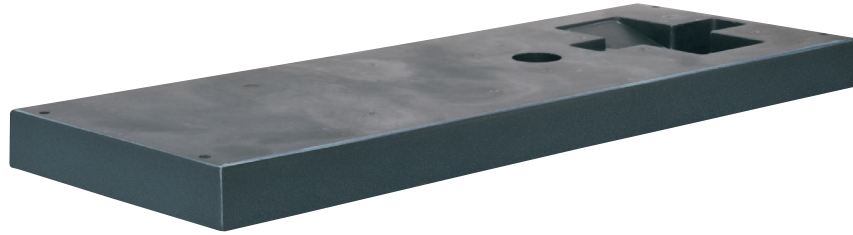

Polymer concrete baseplate offers impressive benefits:

- Low installed cost
- Superior vibration damping
- Corrosion resistance
- Superior resistance to twisting or diaphragming
- Optional catch basin and grout holes
- Inserts available for alternate equipment configuration requirements

Baseplates are fundamental to extending pump life

The test stand provides three-corner support of the ungrouted baseplates. The addition of weights on the unsupported fourth corner caused baseplate distortion. This distortion resulted in measurable shaft movement that can cause problems with field installations and negatively affect pump reliability and life.

The twist test is a means of comparing rigid baseplate designs. Correctly installed rigid baseplates should not experience these twist effects. For more information about the results of baseplate testing, contact your local Flowserve sales representative.

Vibration damping of polymer concrete versus cast iron

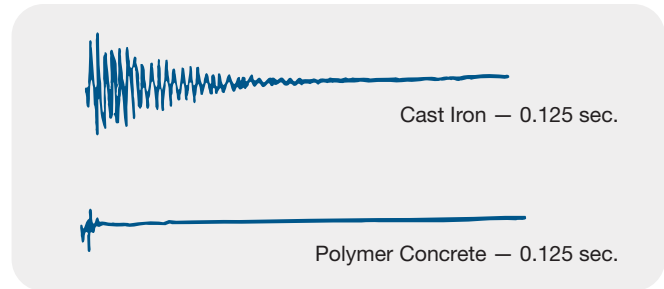

© John F. Kane, Composites Institute, The Society of the Plastics Industry, Inc.

Baseplate rigidity test — twist mode

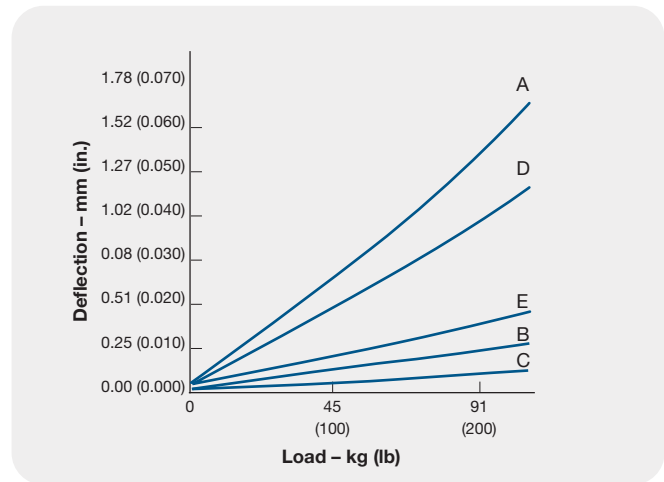

Maximum parallel shaft deflection at applied force

Type A	0.56 mm (0.022 in.)
Type B	0.01 mm (0.004 in.)
Type C	0.08 mm (0.003 in.)
Type D	0.41 mm (0.016 in.)
Type E	0.13 mm (0.005 in.)

Polyshield polymer baseplate and foundation system

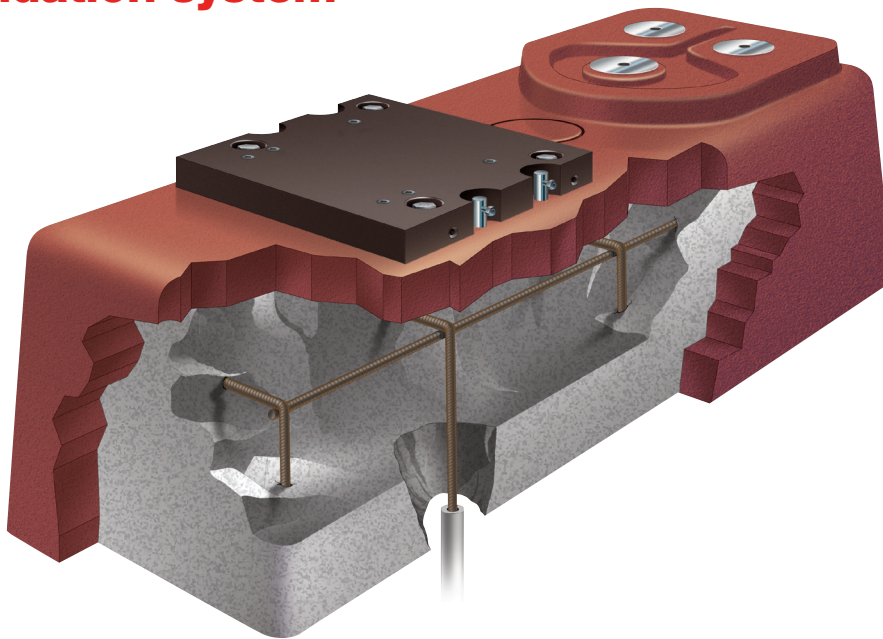

Cost-effective, high-performance baseplate and foundation system

The Polyshield baseplate and foundation system is the superior solution for cost-effective, high-performance pump installation. In one complete unit, it combines a traditional baseplate with a formed concrete foundation for pump-drive sets. Benefits include:

- Time savings
 - Quick installation time
 - Reduces time to commissioning
- Cost savings
 - Reduces total installed cost
 - Dramatically minimizes field rework
- Better performance and reliability
 - Extended pump life
 - Reduced vibration
 - Improved corrosion resistance
- Single-structure convenience
 - One-piece construction
 - Flat mounting surfaces
 - One-piece motor mounting block

Broad application

The Polyshield baseplate and foundation system can be used with numerous pump designs, including:

- ISO and ASME (ANSI) metallic and non-metallic
- Foot- and frame-mounted general industrial
- Foot-mounted between bearings
- ISO 13709/API 610

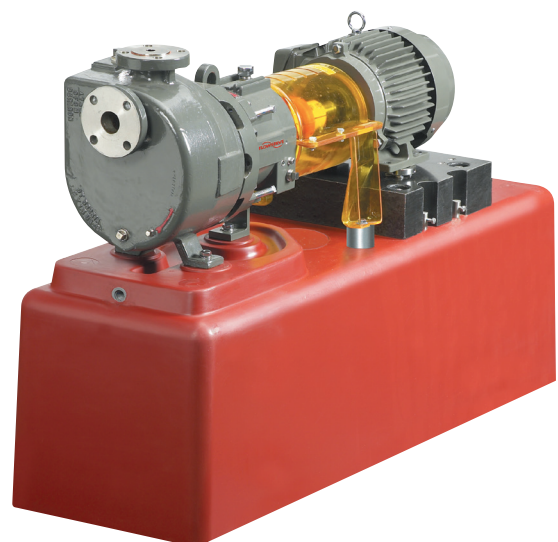

Durco Mark 3 Lo-Flo™ pump

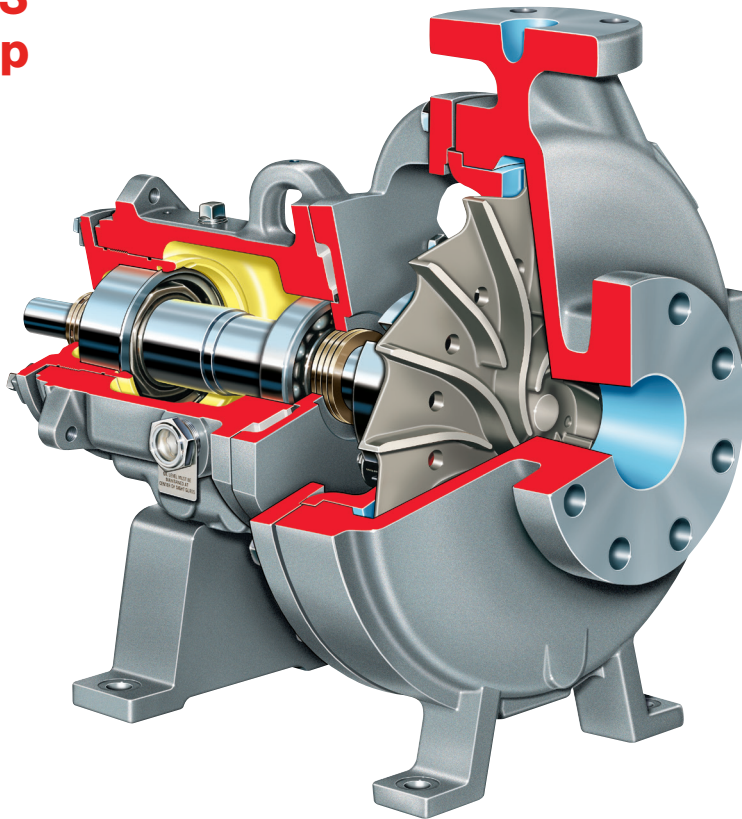

Conforming to ASME (ANSI) B73.1, the Durco Mark 3 Lo-Flo pump is designed to improve pump reliability and performance in low-flow, high-head applications. The first pump manufacturer to introduce an ASME (ANSI) standard low-flow, high-head pump, Flowserve developed its innovative radial vane impeller and circular, concentric casing to reduce radial loads and shaft vibration while extending bearing and mechanical seal life.

Operating parameters

- Flows to 50 m³/h (220 gpm)
- Heads to 300 m (985 ft)
- Pressures to 31 bar (450 psi)
- Temperatures from -75°C to 370°C (-100°F to 700°F)

Four sizes available

- 1K1.5x1LF-4
- 1K1.5x1LF-8
- 2K2x1LF-10
- 2K3x1.5LF-13

Features and benefits

Radial vane impeller provides improved performance over a broader application range.

Circular concentric casing reduces radial loads and vibration and extends bearing and seal life.

SealSentry seal chambers extend seal life and provide advanced self-flushing capability.

External micrometer accurately sets impeller clearance in 20 seconds, whether in the shop or in the field.

Back pullout design allows removal of rotating element without removing casing, piping or motor.

Heavy-duty pump end and drive end bearings are selected for long life and reliability.



Expanding volute casing

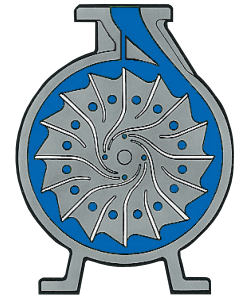

Circular concentric casing

Innovative radial vane impeller design

The Durco Mark 3 Lo-Flo pump features an innovative radial vane impeller that has a unique twist to provide superior performance in low-flow, high-head conditions.

Improved performance and reliability

The radial vane impeller and circular, concentric casing of the Mark 3 Lo-Flo pump improve pump performance and reliability when compared to standard pumps. Maintenance is also reduced.

- Reduced radial loads up to 90% at low flows
- Minimized thrust loads
- Reduced NPSHR
- Reduced shaft vibration (*see graph below*)
- Extended bearing and mechanical seal life
- Broadened application range

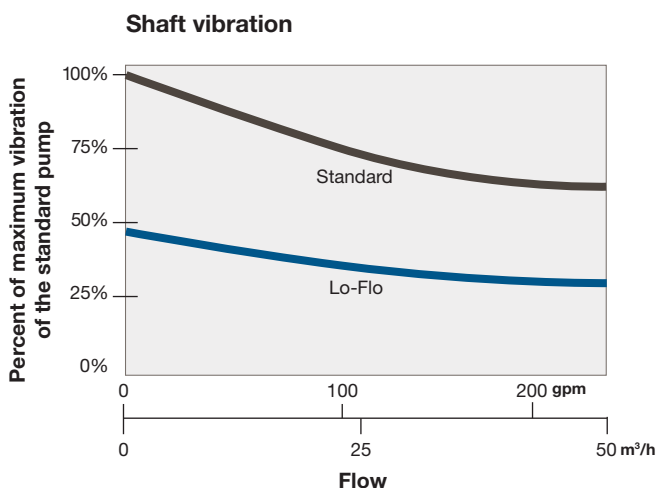

Efficient circular concentric casing

The circular concentric casing of the Durco Mark 3 Lo-Flo pump is more hydraulically efficient at lower flow rates than conventional volute casings. The key to the casing's efficiency is an internal bypass — drilled in the discharge without breaching the casing wall or creating a potential leak path — which helps to balance pressures.

Typical applications

- Acid transfer
- Chemical and petrochemical processing
- Food and beverage processing
- Pharmaceuticals
- Polymers
- Pulp and paper
- Seawater
- Slurries
- Solvents
- Steel and primary metals
- Water and wastewater treatment

Durco Mark 3 Sealmatic™ pump

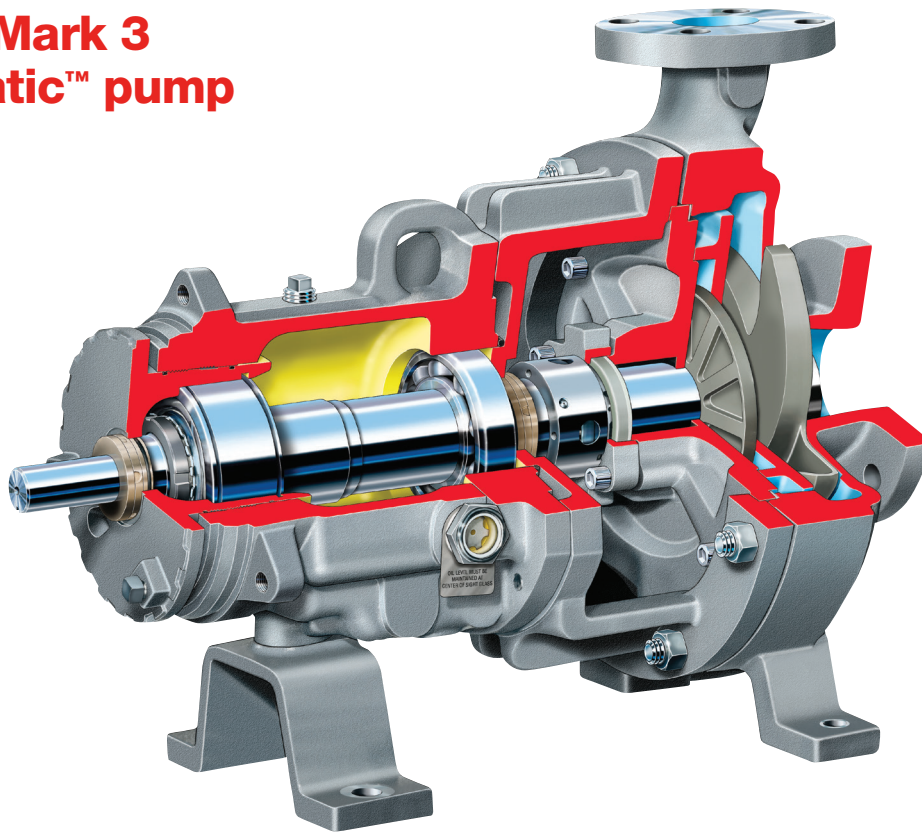

With the Durco Mark 3 Sealmatic pump, no mechanical seal is needed during operation. A dynamically sealing repeller (expeller) expels fluid from the seal chamber, making the Sealmatic pump ideal for hard-to-seal applications. External flushing and process contamination control are no longer needed. Conforms to ASME (ANSI) B73.1.

Operating parameters

- Flows to 1,680 m³/h (7,400 gpm)
- Heads to 230 m (755 ft)
- Pressures to 31 bar (450 psi)
- Temperatures from -75°C to 370°C (-100°F to 700°F)

Eighteen sizes available

- 12 Group 2
- 6 Group 3

Features and benefits

Spinning repeller expeller creates centrifugal force to expel fluid from the seal chamber.

Standard reverse vane impeller is the only impeller design that offers repeatable performance throughout the life of the pump. Open impeller available.

External micrometer accurately sets impeller clearance in 20 seconds, in the shop or in the field.

Back pullout design allows removal of rotating element without removing casing, piping or motor.

Heavy-duty pump end and drive end bearings are selected for long life and reliability.

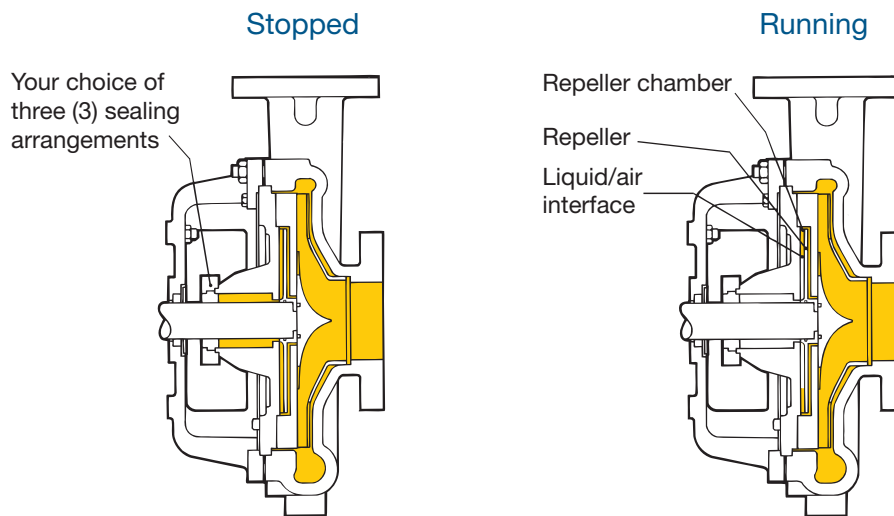

Dynamically sealing repeller

The Durco Mark 3 Sealmatic pump is equipped with a dynamically sealing repeller. This technology enables users to significantly reduce pump lifecycle costs in demanding applications by eliminating the needs for:

- Conventional mechanical seals and their associated maintenance costs
- External flush and the associated product dilution
- Contamination control



Operating principle

The key to the Sealmatic pump's dynamic sealing technology is centrifugal force. As liquid is drawn into the eye of the impeller, the centrifugal force created by the rapidly rotating repeller expels liquid from the seal chamber. In so doing, the pressure of the liquid in the pump and atmospheric pressure are equalized, creating a liquid/air interface and prohibiting shaft leakage.

Choice of static sealing options

For positive sealing while the pump is stopped, Flowserve offers a choice of low-cost alternatives to mechanical seals, including:

- Self-lubricating, flexible graphite packing
- The FXP stationary fluoropolymer disk seal
- Dry-running, end-face seal
- Elastomeric lip seals

These static sealing options have the additional benefit of not requiring external flush.

Typical applications

- Hard-to-seal liquids (e.g., sodium hydroxide, mineral acids, phosphoric acid, sulfuric acid)
- Applications in which seal flush is undesirable (e.g., evaporator feed service, ethanol production)
- Continuous-duty applications (e.g., recirculation in starch conversion)
- Liquids containing solids
- Batch operations where run-dry conditions might exist (e.g., tank unloading)



Durco Mark 3 Unitized Self-Priming pump

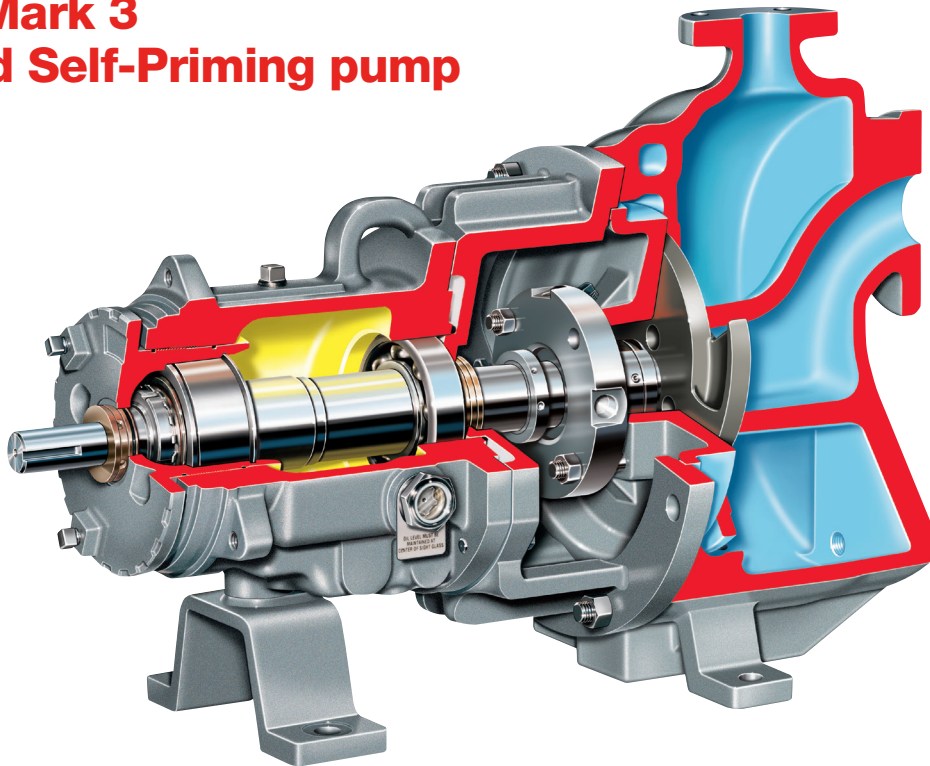

The Durco Mark 3 Unitized Self-Priming pump is engineered to draw from liquid sources below ground level or from sources which have no positive pressure to naturally prime the pump. It is conveniently located high and dry at ground level, where installation is simple and maintenance is easily and more economically performed. As a result, the Mark 3 Self-Priming pump costs less to buy, install and maintain than submersible pumps.

Operating parameters

- Flows to 320 m³/h (1,400 gpm)
- Heads to 120 m (400 ft)
- Pressures to 20 bar (285 psi)
- Temperatures to 370°C (700°F)
- Static suction lift to 6 m (20 ft)

Eleven sizes available

- 3 Group 1
- 8 Group 2

Features and benefits

Unitized casing has large priming chamber, air separator and volute in one integral component. This design eliminates the need for a separate priming tank.

Standard reverse vane impeller is the only impeller design that offers repeatable pump performance throughout the life of the pump. Open impellers available.

External micrometer accurately sets impeller clearance in 20 seconds, whether in the shop or in the field.

SealSentry seal chambers extend seal life and provide advanced self-flushing capability.

Back pullout design allows removal of rotating element without removing casing, piping or motor.

Heavy-duty pump end and drive end bearings are selected for long life and reliability.

Initial prime and priming chamber

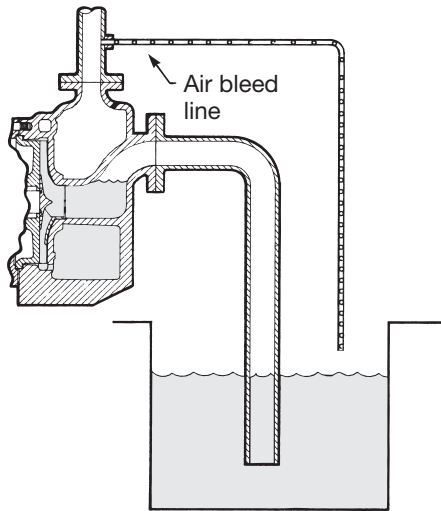

Pump startup and priming

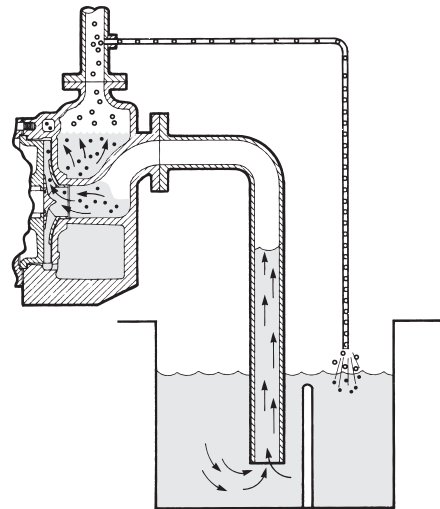

The priming principle

The Durco Mark 3 Unitized Self-Priming pump uses liquid recirculation to prime the pump. The pressure differential between the aerated liquid at the impeller and the non-aerated liquid in the priming chamber creates a vacuum that pulls liquid up the pipe. As a result, the Durco Mark 3 Unitized Self-Priming pump is ideal for suction lift applications or for pumping liquids with air or gas phases.

Benefits of the Mark 3 Unitized Self-Priming pump

- Eliminates internal valves
- Eliminates external priming devices or foot-valves
- Portable
- Compact
- Easy to install
- Easy to maintain

Compact design

The Mark 3 Self-Priming pump's compact design enables it to fit in tight clearance locations. It also can be mounted on a trailer for transportation to various pumping areas, such as for wastewater lagoon service.

Typical applications

- Sump service
- Tank car unloading
- Duplex pumping lift station
- Fly ash pond transfer
- Waste acid transfer
- Waste treatment lagoon service



Durco Mark 3 Recessed Impeller pump

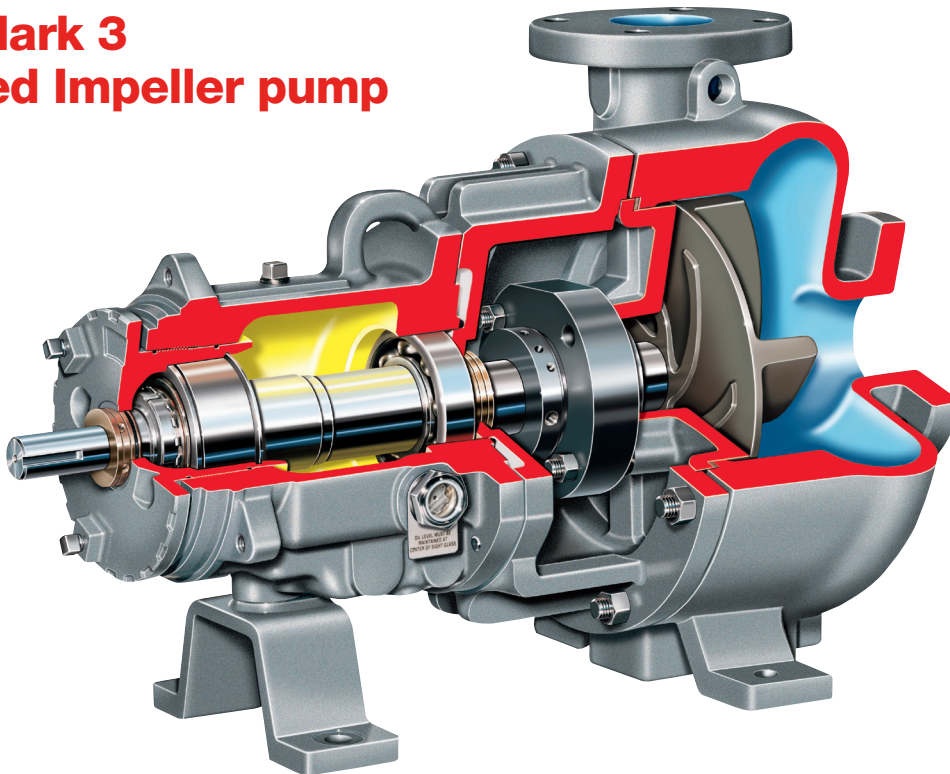

The Durco Mark 3 Recessed Impeller pump combines the best design features of the Mark 3 ASME (ANSI) Standard pump with the vortex action of a recessed impeller. These, along with thick wall wet-end components, extend pump and seal (or packing) service life when handling solid, stringy or fibrous slurries.

Operating parameters

- Flows to 455 m³/h (2,000 gpm)
- Heads to 120 m (400 ft)
- Pressures to 20 bar (285 psi)
- Temperatures from -75°C to 370°C (-100°F to 770°F)

Five sizes available

- 1 Group 1
- 4 Group 2

Features and benefits

Recessed impeller design creates a vortex action which expels solids from critical areas.

Standard CD4MCuN duplex stainless steel construction provides outstanding wear and abrasion resistance. Also available in all standard Mark 3 alloys.

Cylindrical volute casing with tangential discharge minimizes turbulence and decreases abrasion.

External micrometer accurately sets impeller clearance in 20 seconds, whether in the shop or in the field.

SealSentry seal chambers extend seal life and provide advanced self-flushing capability.

Back pullout design allows removal of rotating element without removing casing, piping or motor.

Heavy-duty pump end and drive end bearings are selected for long life and reliability.

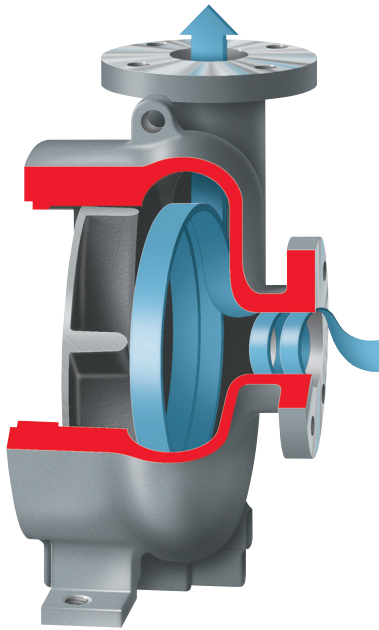

Vortex pumping action improves solids handling capability and reliability

The Durco Mark 3 Recessed Impeller pump boasts a wide clearance at the front of the open impeller, allowing passage of larger particles. The vortex created by the spinning impeller minimizes abrasive wear while maintaining solids integrity — less than 20% of media contacts the impeller.

- Improved solids handling
- Improved air and gas handling
- Improved ability to pass fibrous or stringy substances
- Improved seal or packing life
- Reduced wear
- Low NPSHR

Cylindrical volute casing

The cylindrical volute casing with tangential discharge minimizes radial loads on the impeller and reduces turbulence. The result is longer seal life as well as maximized radial bearing life.

High-efficiency open impeller

The Durco Mark 3 Recessed Impeller pump comes standard with a precision cast open impeller that ensures peak energy efficiency and low NPSHR. The design incorporates pump-out vanes that prolong mechanical seal or packing life by:

- Ensuring low, positive seal chamber pressure
- Expelling solids from critical seal
- Providing axial hydraulic balance



Additional configurations

The Mark 3 Recessed Impeller pump can be specified with the Sealmatic dynamically sealing repeller and as self-priming with a priming tank option.

Typical applications

- Light slurries
- Corrosive or erosive services
- Large-diameter solids
- Waste streams
- Fluids with which shearing must be avoided
- Protection of solids integrity



Durco Mark 3 pump family

Durco Mark 3 In-Line pump

Designed to exceed ASME (ANSI) B73.2 criteria, the Durco Mark 3 In-Line process pump incorporates many of the same advanced design features as other Mark 3 models, such as reverse vane impeller, SealSentry seal chambers and external micrometer impeller adjustment. In addition, this space-saving pump has its own independent bearing housing and rigid style motor adapter.

Please refer to bulletin PS-10-15 for additional product information.

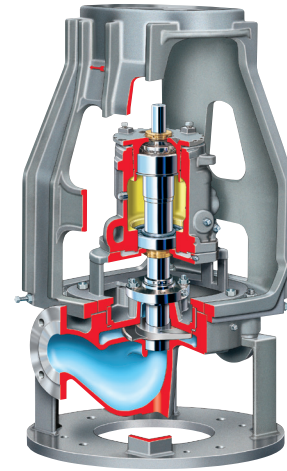

Durco Mark 3 Group 4 high-capacity pump

Designed to complement the Durco Mark 3 pump, the Mark 3 Group 4 pump delivers flow rates well beyond traditional ASME (ANSI) pump sizes. Outside the scope of the ASME (ANSI) performance and dimensional requirements, the Group 4 is designed for maximum reliability and efficiency in demanding high-flow applications.

Please refer to bulletin PS-10-39 for additional product information.

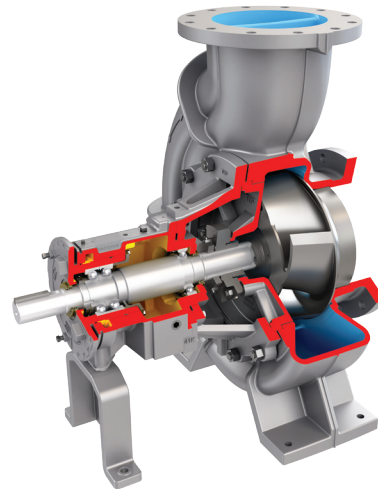

Guardian™ ASME (ANSI) magnetic drive pump

Guardian magnetic drive pumps meet ASME (ANSI) B73.1 dimensional standards and are available in 18 sizes. Offered in a wide range of corrosion-resistant materials, the Guardian magnetic drive pump is ideal for high-temperature, leak-free applications.

Please refer to bulletin PS-10-14 for additional product information.

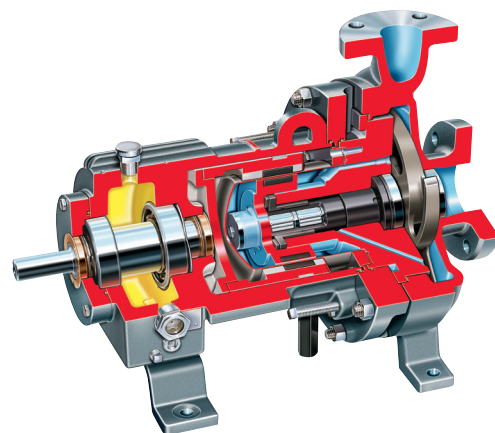



*Durco Mark 3 ISO
chemical process pump*

Complementary pumps designed to ISO specifications

Conforming to ISO 2858, ISO 5199 and ISO 15783 design criteria, Durco Mark 3 ISO chemical process pumps incorporate many of the same reliability- and performance-enhancing features as Durco Mark 3 ASME pumps. They provide outstanding hydraulic efficiency, unrivaled dependability and low total cost of ownership.

Durco Mark 3 ISO chemical process pumps are available in many designs and configurations to meet the needs of the process industries:

Mechanically sealed

- Flexibly coupled
- Close coupled
- Self-priming
- Recessed impeller
- Vertical sump

Sealless, magnetic drive

- Flexibly coupled
- Close coupled
- Heat barrier

Please refer to bulletin PS-10-31 for additional product information.



CPXV vertical metallic sump pump



Durco Mark 3 ISO Mag close coupled pump

Complementary non-metallic and lined pumps

PolyChem™ non-metallic chemical process pumps

Embracing a global approach to pump design, Flowserve offers sealed PolyChem non-metallic pumps engineered to ASME (ANSI) design criteria. The fluoropolymer-lined S-Series pump and the GRP engineered polymer composite pump are well-suited for highly corrosive applications in the worldwide process industries.

- PolyChem S-Series: fluoropolymer-lined, mechanically sealed
- PolyChem GRP: engineered composite

Please refer to bulletin PS-10-17 for additional product information.

INNOMAG® TB-MAG™ fluoropolymer-lined magnetic drive pump

Compliant with ASME B73.3 or ISO 2858 dimensional standards, this versatile pump provides low total cost of ownership and exceptional leakage protection in extremely corrosive and environmentally critical applications. Its revolutionary dynamic thrust balancing system eliminates the need for thrust bearings and results in highly efficient operation with outstanding reliability, even in applications containing solids.

Please refer to bulletin PS-10-36 for additional product information.

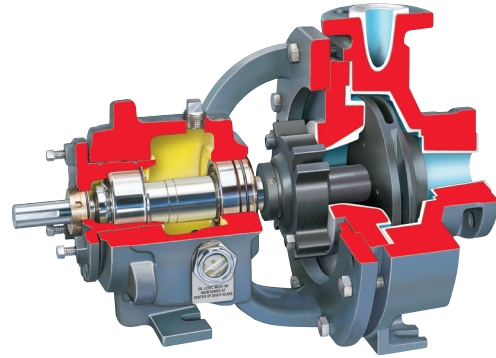

PolyChem S-Series

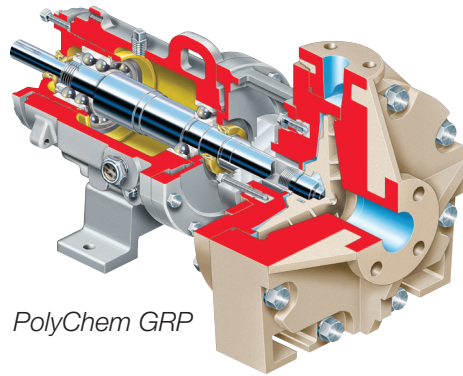

PolyChem GRP

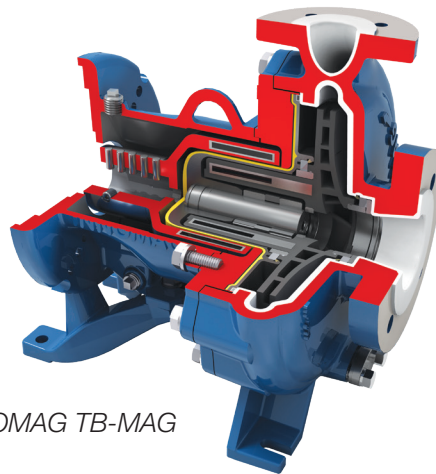

INNOMAG TB-MAG





Lifecycle cost solutions

Typically, 90% of the total lifecycle cost of a pumping system is accumulated after the equipment is purchased and installed. Flowserve has developed a comprehensive suite of solutions aimed at providing customers with unprecedented value and cost savings throughout the lifespan of the pumping system. These solutions account for every facet of lifecycle cost, including:

Capital expenses

- Initial purchase
- Installation

Operating expenses

- Energy consumption
- Maintenance
- Production losses
- Environmental
- Inventory
- Operating
- Removal

Innovative lifecycle cost solutions

- New pump selection
- Turnkey engineering and field service
- Energy management
- Pump availability
- Proactive maintenance
- Inventory management

Typical pump lifecycle costs¹

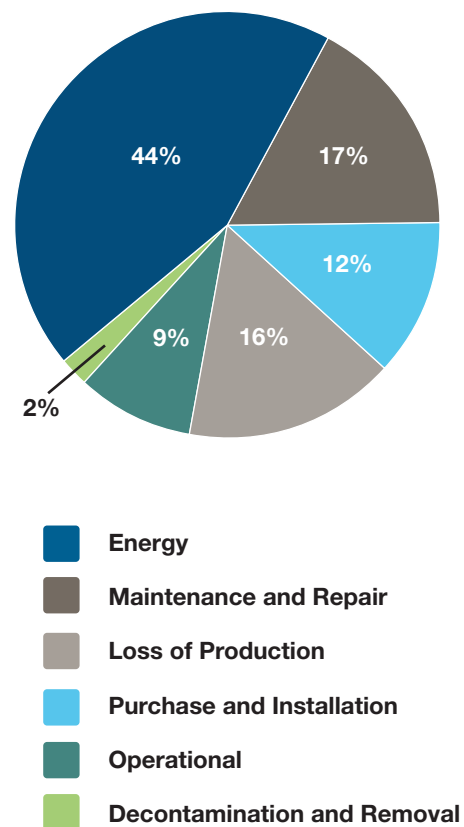

¹ While exact values may differ, these percentages are consistent with those published by leading pump manufacturers and end users, as well as industry associations and government agencies worldwide.

CELEBRATING

50

YEARS OF EXPERIENCE

**EXPERIENCE INNOVATIVE
THINKERS AND PRODUCTS**



ALL ABOUT EXPERIENCE

allpumps.com.au

1300 255 786 | sales@allpumps.com.au