

6GHT SAE MOUNT GLOBAL HIGH PERFORMANCE TRASH



Global Pump® High Performance Trash pumps are specifically designed to effectively handle a wide-range of liquids from water to sewage and sludge that can contain solids and other material.

Global Pump High Performance Trash pumps provide a dependable, highly efficient solution. The model 6GHT SAE Mount is capable of achieving maximum flows of 3,200 gpm (727 m³/h) and maximum total head of 223' (68 m) while handling solids up to 3" (76.2 mm) in diameter.

The standard 6GHT SAE Mount is SAE flange mounted to a water-cooled, 4-cylinder diesel engine. Alternative drives are available including electric motors.

Global Pump's unique front pullout cartridge seal provides ease of maintenance as it can be quickly changed in the field, thereby reducing downtime and expense.

FEATURES

Global Pump's rugged, heavy duty pumps are engineered specifically for portable application

Close coupled SAE mount to engine

Industry-best shaft stiffness with extremely low L³/D⁴ ratio that provides minimal shaft deflection, extended seal life and L10 100,000 hour bearing life

Non-return valve uses only a single moving part to allow full flow with minimal restriction

Standard engine control panel provides preset emergency shutdown protection and allows the addition of automatic level control

Global Pump's unique cartridge seal with biodegradable glycol quench allows the pump to start and run dry

Pump casings are hydrostatically tested to 50 psig (345 kPa) above the peak casing design pressure

Skid-mounted formats with tie downs, lifting bail, and fork pockets

OPTIONS

Available with a variety of priming systems, including Global's Auto Prime® automatic priming system (compressor-fed venturi priming) or a diaphragm priming system

Global Pump's environmental box separates and silences air exhaust and returns liquid to the pump suction

Fuel cubes for extended run times and/or remote location as required

Sound attenuated enclosure options

Hose racks, accessory containers and other custom features available as required

Wide range of suction and discharge fittings including Global Pump's own "QD" Quick Disconnect fittings and accessories

6GHT SAE MOUNT **GLOBAL HIGH PERFORMANCE TRASH**

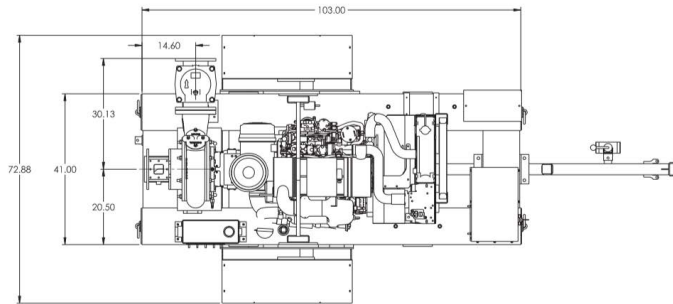
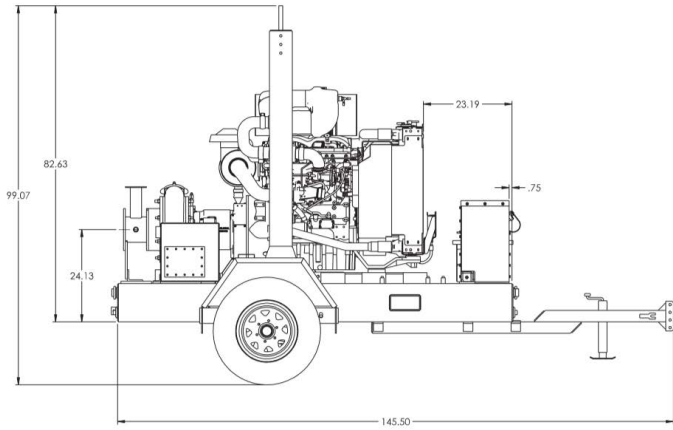

SPECIFICATIONS

Connections	6" (150 mm) ANSI Flanges
Max Pump Speed	2,000 rpm
Max Flow	3,200 gpm (727 m ³ /h)
Max Head	223' (68 m)
Max Static Priming Lift	28' (8.5 m)
Temperature Limit	160° F (70° C)
Solids Handling Capability	3" (76.2 mm)
Max Casing Pressure	125 psig (862 kPa)
Fuel Cell	118 gallons (446 liters)
Dry Weight	4,000 lbs

PUMP MATERIAL

Casing	Cast Iron (CD4MCu is an option)
Impeller	Cast Iron (CD4MCu is an option)
Bearing Housing	Cast Iron
Bearing Lubrication	Grease
Shaft/Shaft Sleeve	Steel/FNC Treated Steel
Seal	Silicon Carbide on Silicon Carbide
Chassis/Fuel Cell	Steel
Non-Return Valve	Nitrile Fitted Cast Iron

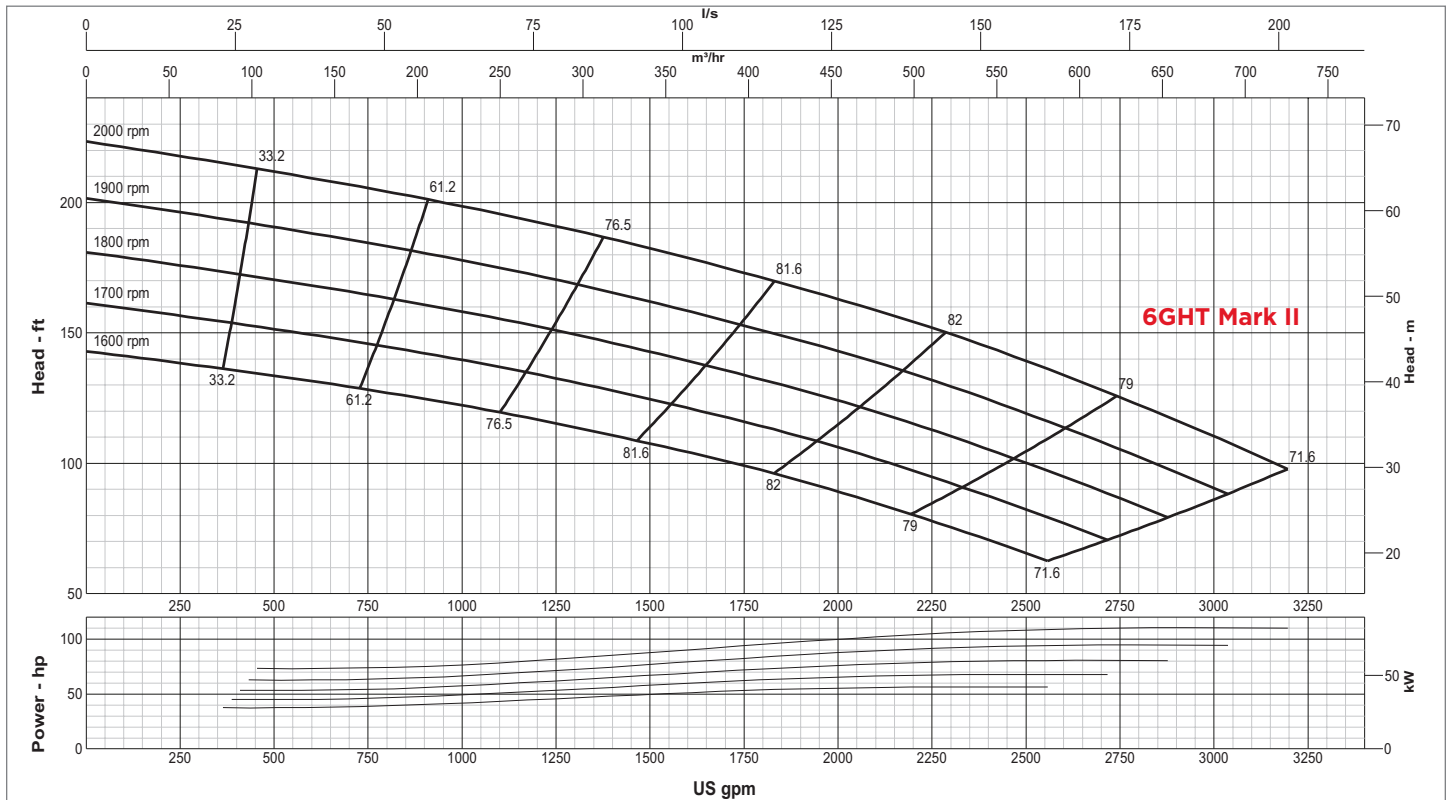

GLOBAL PUMP
 10162 East Coldwater Road, Davison, MI 48423
 Tel: 810.653.4828 Fax: 810.658.0632
1.866.360.PUMP www.globalpump.com