

SaniForce™ 5:1 Sanitary Pumps

3A0734S
EN

**For use in sanitary applications to transfer medium to high viscosity fluids.
For professional use only.**

See page 2 for model information, including maximum fluid working pressure.



Important Safety Instructions

Read all warnings and instructions in this manual. Save these instructions.

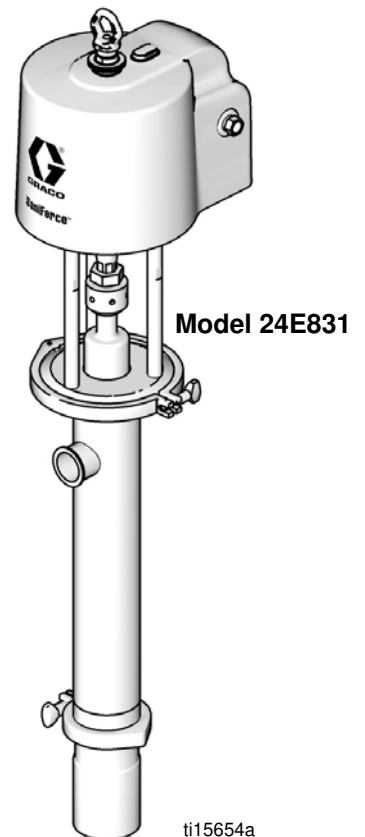
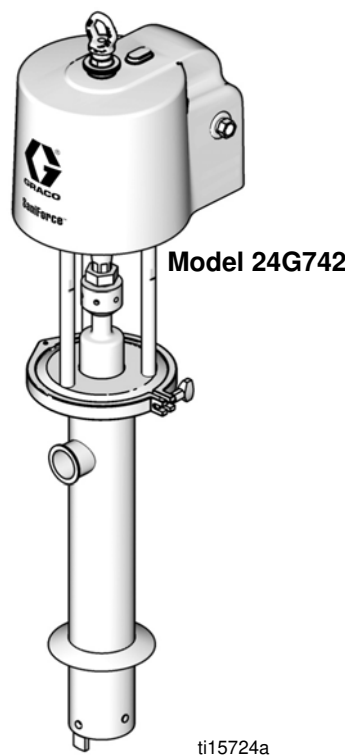

Contents

Models	2	Priming Piston Service	11
Warnings	4	Disconnect the Pump	11
Installation	6	Disassemble the Pump	12
Grounding	6	Reassemble After Cleaning	13
Mounting	6	Reconnect the Pump	13
Setup	6	Double-Ball Service	14
Operation	8	Disconnect the Pump	14
Pressure Relief Procedure	8	Disassemble the Pump	14
Flush Before First Use	8	Reassemble After Cleaning	16
Adjusting the Pump Speed and Pressure	8	Reconnect the Pump	16
Pump Shutdown	8	Parts	18
Maintenance	9	Dimensions	26
Flushing Procedure	9	Performance Chart	28
Cleaning Procedure	9	Technical Data	29
Tighten Connections	9	Graco Standard Warranty	30
Troubleshooting	10		

Models

Maximum Air Inlet Pressure: 80 psi (0.6 MPa, 5.5 bar)

Maximum Fluid Working Pressure: 410 psi (2.8 MPa, 28.3 bar)

Pump Model	Displacement Pump Model	Pump Type	Pump Length Description	Packings
24E831	24G760	Priming Piston	Drum Length	Buna, FKM, Nylon, Polychloroprene, PTFE, and UHMWPE
24E833	24G755	Double Ball	Stubby	Buna, FKM, PTFE, and UHMWPE
24F195	24G756	Double Ball	Drum Length	Buna, FKM, PTFE, and UHMWPE
24F196	24G758	Double Ball	Stubby, with Inlet Elbow	Buna, FKM, PTFE, and UHMWPE
24F197	24G757	Double Ball	Stubby	Buna, FKM, PTFE, Silicone, and UHMWPE
24G741	24G759	Priming Piston	Drum Length, with Flange for Ram	Buna, FKM, Nylon, Polychloroprene, PTFE, and UHMWPE
24G742	24G754	Double Ball	Stubby, with Flange for Ram	Buna, FKM, PTFE, and UHMWPE













All models are compliant with:





EC 1935/2004 compliant pumps may be subject to individual national provisions in addition to those specified in the EC regulation. It is the users responsibility to know and follow local laws.

Warnings

The following warnings are for the setup, use, grounding, maintenance, and repair of this equipment. The exclamation point symbol alerts you to a general warning and the hazard symbols refer to procedure-specific risks. When these symbols appear in the body of this manual, refer back to these Warnings. Product-specific hazard symbols and warnings not covered in this section may appear throughout the body of this manual where applicable.



 WARNING	
  	<p>SKIN INJECTION HAZARD</p> <p>High-pressure fluid from dispensing device, hose leaks, or ruptured components will pierce skin. This may look like just a cut, but it is a serious injury that can result in amputation. Get immediate surgical treatment.</p> <ul style="list-style-type: none"> • Do not point dispensing device at anyone or at any part of the body. • Do not put your hand over the fluid outlet. • Do not stop or deflect leaks with your hand, body, glove, or rag. • Follow the Pressure Relief Procedure when you stop dispensing and before cleaning, checking, or servicing equipment. • Tighten all fluid connections before operating the equipment. • Check hoses and couplings daily. Replace worn or damaged parts immediately.
 	<p>MOVING PARTS HAZARD</p> <p>Moving parts can pinch, cut or amputate fingers and other body parts.</p> <ul style="list-style-type: none"> • Keep clear of moving parts. • Do not operate equipment with protective guards or covers removed. • Pressurized equipment can start without warning. Before checking, moving, or servicing equipment, follow the Pressure Relief Procedure and disconnect all power sources.
   	<p>FIRE AND EXPLOSION HAZARD</p> <p>Flammable fumes, such as solvent and paint fumes, in work area can ignite or explode. To help prevent fire and explosion:</p> <ul style="list-style-type: none"> • Use equipment only in well ventilated area. • Eliminate all ignition sources; such as pilot lights, cigarettes, portable electric lamps, and plastic drop cloths (potential static arc). • Keep work area free of debris, including solvent, rags and gasoline. • Do not plug or unplug power cords, or turn power or light switches on or off when flammable fumes are present. • Ground all equipment in the work area. See Grounding instructions. • Use only grounded hoses. • Hold gun firmly to side of grounded pail when triggering into pail. • If there is static sparking or you feel a shock, stop operation immediately. Do not use equipment until you identify and correct the problem. • Keep a working fire extinguisher in the work area.

WARNING

 	<p>EQUIPMENT MISUSE HAZARD</p> <p>Misuse can cause death or serious injury.</p> <ul style="list-style-type: none"> • Do not operate the unit when fatigued or under the influence of drugs or alcohol. • Do not exceed the maximum working pressure or temperature rating of the lowest rated system component. See Technical Data in all equipment manuals. • Use fluids and solvents that are compatible with equipment wetted parts. See Technical Data in all equipment manuals. Read fluid and solvent manufacturer's warnings. For complete information about your material, request MSDS from distributor or retailer. • Do not leave the work area while equipment is energized or under pressure. Turn off all equipment and follow the Pressure Relief Procedure when equipment is not in use. • Check equipment daily. Repair or replace worn or damaged parts immediately with genuine manufacturer's replacement parts only. • Do not alter or modify equipment. • Use equipment only for its intended purpose. Call your distributor for information. • Route hoses and cables away from traffic areas, sharp edges, moving parts, and hot surfaces. • Do not kink or over bend hoses or use hoses to pull equipment. • Keep children and animals away from work area. • Comply with all applicable safety regulations.
	<p>SPLATTER HAZARD</p> <p>Hot or toxic fluid can cause serious injury if splashed in the eyes or on skin. During blow off of platen, splatter may occur.</p> <ul style="list-style-type: none"> • Use minimum air pressure when removing platen from drum.
	<p>TOXIC FLUID OR FUMES HAZARD</p> <p>Toxic fluids or fumes can cause serious injury or death if splashed in the eyes or on skin, inhaled, or swallowed.</p> <ul style="list-style-type: none"> • Read MSDSs to know the specific hazards of the fluids you are using. • Store hazardous fluid in approved containers, and dispose of it according to applicable guidelines.
	<p>PERSONAL PROTECTIVE EQUIPMENT</p> <p>You must wear appropriate protective equipment when operating, servicing, or when in the operating area of the equipment to help protect you from serious injury, including eye injury, hearing loss, inhalation of toxic fumes, and burns. This equipment includes but is not limited to:</p> <ul style="list-style-type: none"> • Protective eyewear, and hearing protection. • Respirators, protective clothing, and gloves as recommended by the fluid and solvent manufacturer.

Installation

Grounding

							
<p>The equipment must be grounded. Grounding reduces the risk of static and electric shock by providing an escape wire for the electrical current due to static build up or in the event of a short circuit.</p>							

Pump: Connect a ground wire (Graco PN 238909) to the ground screw on the bottom cover of the air motor, under the shroud. Connect the other end of the ground wire to a true earth ground.

Air and fluid hoses: use only electrically conductive hoses with a maximum of 500 ft. (150 m) combined hose length to ensure grounding continuity. Check electrical resistance of hoses. If total resistance to ground exceeds 25 megohms, replace hose immediately.

Air compressors: follow manufacturer's recommendations.

Dispense valve: ground through connection to a properly grounded fluid hose and pump.



Material supply container: follow local code.

Container(s) that receive material: follow local code.

Solvent pails used when flushing: follow local code. Use only conductive metal pails, placed on a grounded surface. Do not place the pail on a nonconductive surface, such as paper or cardboard, which interrupts grounding continuity.



To maintain grounding continuity when flushing or relieving pressure: hold metal part of the dispense valve firmly to the side of a grounded metal pail, then trigger the valve.

Mounting

							
<p>To avoid injury from a falling pump, check the torque on the lift ring (19) and nut (18) before using the lift ring to lift the pump. Torque to 30-36 ft-lb (41-49 N•m).</p>							

Mount the pump on a surface than can support the weight of the pump and accessories, as well as the stress caused during operation. Do not use air or fluid lines to support the pump.

Setup

							
<p>To avoid contaminating the fluid, pipe the exhaust air to vent outside of the fluid product area, away from people, animals, or food-handling areas.</p>							

NOTE: Reference numbers and letters in parentheses in the text refer to the callouts in the figures and the parts drawings.

Accessories are available from Graco. Make certain all accessories are sized and pressure-rated to meet your system requirements.

FIG. 1 is only a guide for selecting and installing system components and accessories. Contact your Graco distributor for assistance in designing a system to suit your particular needs.

Install a bleed-type master air valve (G) close to the pump air inlet (D), to relieve air trapped between it and the air motor.

Install an air filter/regulator (F) in the pump air line, *upstream from the bleed valve*, to control air inlet pressure and to remove harmful dirt and contaminants from your compressed air supply.

Install a pump runaway valve (S) in the pump air line to shut off air to the air motor automatically if the pump starts to run too fast.

Install another bleed-type master air valve (G) upstream from all air line accessories and use it to isolate the accessories during cleaning and repair.

Connect air solenoid valves (H) to a timer control (L), and set so the dispense valve (K) will dispense at proper intervals.

On the air drop to the dispense valve (K), install an air regulator (M) to control air pressure to the valve. Install a bleed valve (G) to use as a shutoff when servicing the dispense valve.

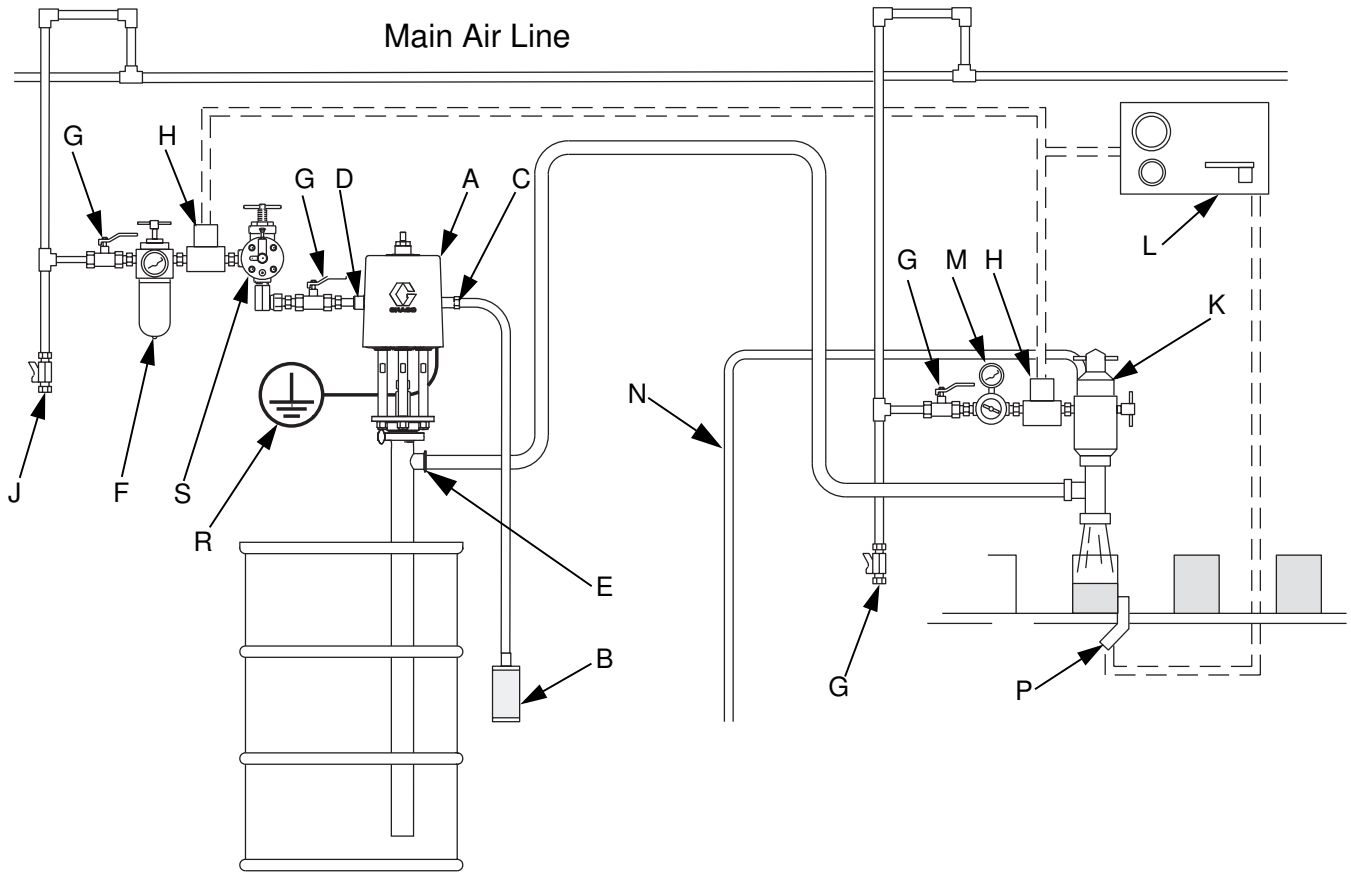

FIG. 1: Typical Installation

ti15638a

Key:

Pump Components (Included)

- A Bung-Mounted Sanitary Pump
- B Air Exhaust Muffler (may alternately be mounted remotely, using exhaust hose)
- C 3/4 npt Exhaust Air Outlet
- D 1/2 npt Air Inlet
- E 1-1/2 in. Tube Size Flanged Fluid Outlet

System Components/Accessories (sold separately)

- F Air Line Filter/Regulator
- G Bleed-Type Master Air Valve (required)
- H Air Solenoid Valve
- J Air Line Drain Pipe and Valve
- K Dispensing Valve
- L Timer Control
- M Air Regulator
- N Dispensing Valve Air Exhaust Hose
- P Sensing Device
- R Pump Ground Wire (required)
- S Pump Runaway Valve

Operation

NOTICE

Do not expose the air motor to temperatures higher than 120°F (49°C) or the immersed fluid pump to temperatures higher than 140°F (60°C). Excessive temperatures may damage the pump packings and seals.

Pressure Relief Procedure



Trapped air can cause the pump to cycle unexpectedly, which could result in serious injury from injection, splashing or moving parts. Relieve pressure when you stop pumping and before cleaning, checking, or servicing equipment.

1. Shut off the air supply to the pump.
2. Close the bleed-type master air valve (required in system).
3. Open the fluid ball valve and/or dispensing valve to relieve fluid pressure.

Flush Before First Use

The sanitary pump was assembled using sanitary lubricant on moving parts and was tested in water. Flush the pump thoroughly with an appropriate cleaning solution, and disassemble and sanitize the parts before using the pump. See **Flushing Procedure**, page 9. Check national, state, and local codes for specific limitations.

Adjusting the Pump Speed and Pressure

Set pressure regulator to 0 psi. Open the bleed-type master air valve. Adjust the pump air regulator until the pump is running smoothly.

Allow the pump to cycle slowly until all air is pushed out of the lines (the fluid will flow in a steady stream from the fluid outlet) and the pump is primed.

With the air supply turned on, the pump will start when the dispensing valve is opened and stall against pressure when the valve is closed. In a circulating system, the pump operates until the air supply is turned off.

NOTICE

Never allow the pump to run dry of fluid. A dry pump will accelerate to a high speed, possibly damaging itself.

If the pump accelerates quickly, or is running too fast, stop the pump immediately and check the fluid supply. If the supply is empty and air has been pumped into the lines, refill the container and prime the pump and lines with fluid. Be sure to eliminate all air from the system.

Pump Shutdown

Follow the **Pressure Relief Procedure**, page 8. Always stop the pump at the bottom of its stroke to prevent fluid from drying on the displacement rod. (The air motor will exhaust at the bottom and top of the stroke.)

Maintenance

Flushing Procedure

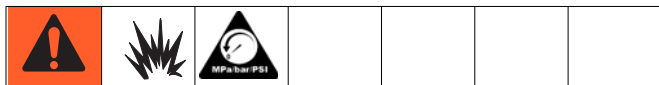

NOTE:

- Flush before fluid can dry in the equipment, at the end of the day, before storing, and before repairing equipment.
 - Flush at the lowest pressure possible. Check connectors for leaks and tighten as necessary.
 - Flush with an appropriate cleaning solution.
1. Remove the pump from the fluid container. Operate it at a slow rate to pump out as much fluid as possible.
 2. Follow **Pressure Relief Procedure**, page 8.
 3. Place siphon tube in grounded metal pail containing an appropriate cleaning solution.
 4. Set pump air regulator to lowest possible fluid pressure, and start pump.
 5. Run the pump long enough to thoroughly clean the pump and hoses.
 6. Follow **Pressure Relief Procedure**, page 8.

Cleaning Procedure

NOTE: The following instructions are a basic procedure for cleaning a sanitary pump.

- **Be sure** to follow your national and state sanitary standard codes and local regulations.
- Use appropriate cleaning and disinfecting agents, at intervals appropriate for product processed.
- Follow cleaning product manufacturer's instructions.

NOTE: The pump **must be disassembled** to clean it thoroughly.

1. Remove the pump from the fluid container. Operate it at a slow rate to pump out as much fluid as possible.

2. Flush the system thoroughly with an appropriate cleaning solution. See **Flushing Procedure**, page 9.
3. Follow the **Pressure Relief Procedure**, page 8.
4. Remove the air and fluid hoses and fittings from the pump.
5. **Ram-Mounted Pumps:** Loosen the hand screw and lift the upper shroud straight up on the rod.
Other Pumps: Remove the upper shroud.
6. Clean thoroughly the surface between the upper and lower shrouds.
7. Disassemble the fluid pump and accessories. See **Priming Piston Service**, page 11, or **Double-Ball Service**, page 14.
8. Wash all pump parts with an appropriate cleaning solution at the cleaning product manufacturer's recommended temperature and concentration.
9. Rinse all pump parts again with water and allow them to dry.
10. Inspect all pump parts and reclean if needed.

NOTE: Any damaged rubber parts **must** be replaced as they could harbor microorganisms that can contaminate the fluid.

11. Immerse all pump parts in an appropriate sanitizer before assembly. Take the pump parts out of the sanitizer one-by-one as needed.
12. Lubricate the moving pump parts and o-rings, packings, and seals with appropriate waterproof sanitary lubricant.
13. Circulate the sanitizing solution through the pump and the system prior to use.
14. **Ram-Mounted Pumps:** Clean all ram surfaces. Remove and clean the inflatable seal and ram plate. See Manual 3A0591.

Tighten Connections

Before each use, check all hoses for wear or damage. Replace as necessary. Check that all connections are tight and leak-free.

Troubleshooting



1. Follow **Pressure Relief Procedure**, page 8.
2. Check all possible remedies in the Troubleshooting Chart before disassembling the pump.

Problem	Cause	Solution
Pump fails to operate.	Restricted air line or inadequate air supply.	Clear air line or increase air supply.
	Insufficient air pressure; closed or clogged air valves, etc.	Open or clean air valves, etc.
	Exhausted fluid supply.	Refill fluid supply.
	Damaged air motor.	Service.
Pump operates, but output low on both strokes.	Restricted air line or inadequate air supply.	Clear air line or increase air supply.
	Insufficient air pressure; closed or clogged air valves, etc.	Open or clean air valves, etc.
	Exhausted fluid supply.	Refill fluid supply.
	Obstructed fluid line, valves, dispensing valve, etc.	Clear. Relieve pressure and disconnect fluid line. Turn on air. If pump starts, the fluid line is clogged.
	Worn throat packing (113).	Replace throat packing.
	Damaged cylinder o-ring (110).	Replace o-ring.
Pump operates, but output low on down stroke.	Held open or worn fluid inlet valve.	Clear or service fluid inlet valve.
	Damaged cylinder o-ring (110).	Replace o-ring.
Pump operates, but output low on up stroke.	Held open or worn fluid piston or seal (111).	Clear or service fluid piston or seal.
Erratic or accelerated operation.	Exhausted fluid supply.	Refill fluid supply.
	Held open or worn fluid inlet valve.	Clear or service fluid inlet valve.
	Held open or worn fluid piston or seal (111).	Clear or service fluid piston or seal.

Priming Piston Service

Disconnect the Pump



Moving parts can pinch, cut or amputate fingers and other body parts. Keep your hands and fingers away from the priming piston during operation and whenever the pump is charged with air.

1. Remove the pump from the fluid container. Operate it at a slow rate to pump out as much fluid as possible.
2. Follow the **Pressure Relief Procedure**, page 8.
3. Remove the air and fluid hoses from the pump. **Ram-mounted pumps:** leave ram air connected for now.

4. Hold the reducer fitting with a wrench. Use a spanner wrench (T)* to loosen the coupling nut.
 - *A Graco spanner wrench tool (p/n 112887) is available.

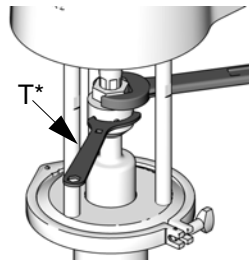

ti15652a

5. Lower the coupling nut enough to remove the coupling collars.

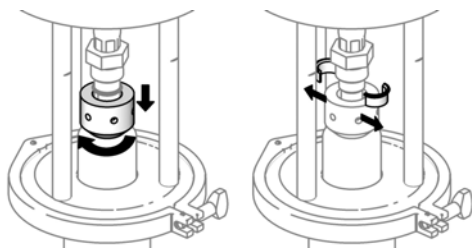

ti15653a

6. Remove the clamp holding the pump base to the ram or drum. **Ram-mounted pumps:** Use the ram to lift the air motor. Disconnect air lines.
7. Remove the clamp (C) holding the lower (L) to the tie rod plate (P).
8. Carry the lower to the bench for service.

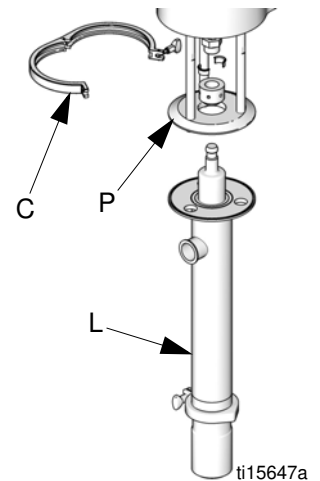

ti15647a

Disassemble the Pump

NOTE: Pump Repair Kit 24G552 is available. Purchase the kit separately. See the Parts list on page 21. Kit parts are marked with an *.

1. Remove the connecting rod pin (122). Remove the piston (121).
2. Release the clamp (115) to remove the inlet valve housing (102) from the pump cylinder (101). Remove the gasket (116).
3. Slide the poppet (119), packings (120), bearing (118), and valve stop (117) off the connecting rod (104).

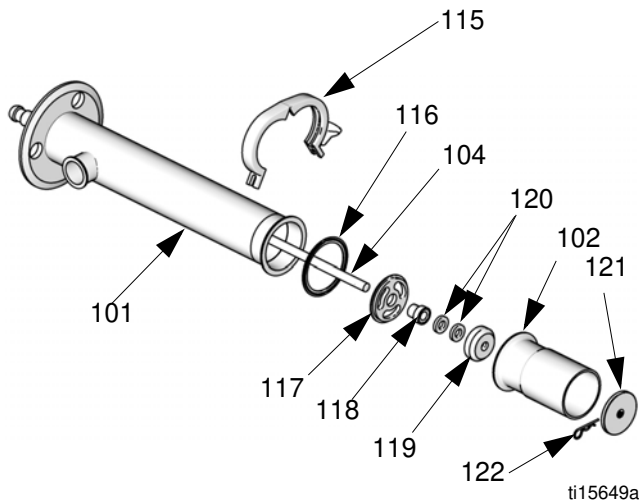
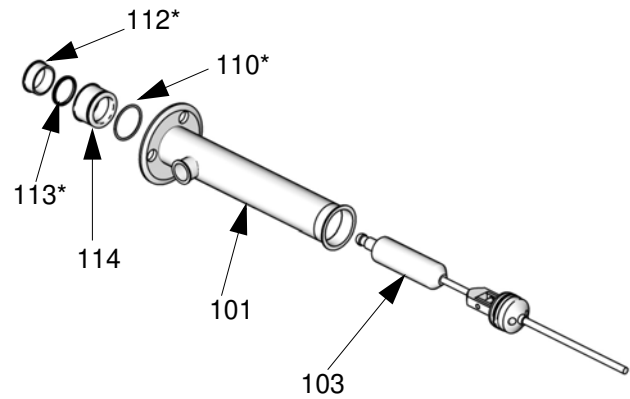

FIG. 2. Remove priming piston

4. See FIG. 3. Push the displacement rod (103) down as far as possible, then pull it out the bottom of the cylinder (101).

5. Remove the bearing (112), packing (113), packing housing (114), and o-ring (110).



ti15650a

FIG. 3. Remove displacement rod

6. Remove the retaining pin (106) and o-rings (105). Pull the connecting rod (104) from the displacement rod (103). Remove the ball (107), piston ring (108), seal (111), and o-rings (109, 110).

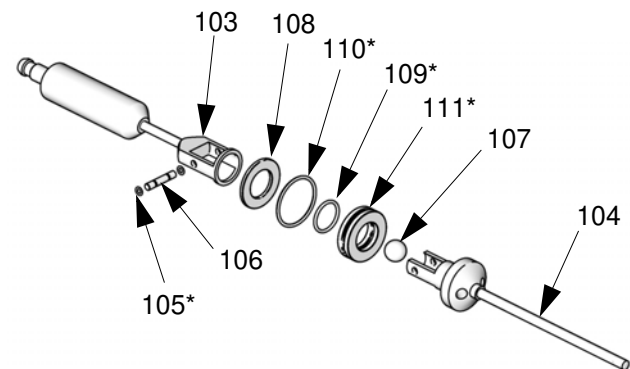

ti15651a

FIG. 4. Disassemble piston valve

7. Refer to the **Cleaning Procedure** on page 9. Clean the parts and inspect them for wear or damage. Replace them as necessary.

Reassemble After Cleaning

NOTE: Any damaged rubber parts **must** be replaced as they could harbor microorganisms that can contaminate the fluid.

NOTE: Lubricate the o-rings, throat packings, and piston seals with appropriate waterproof sanitary lubricant prior to installation.

1. Install the v-block packing (113*) and bearing (112*) in the packing housing (114). The lips of the packing must face down into the housing, and the lip of the bearing must face up. Install the o-ring (110*) on the outside of the housing. Place the packing housing in the top of the cylinder.
2. Install the o-rings (109*, 110*) on the piston seal (111*). Install the seal on the piston valve housing at the top of the connecting rod (104). Install the piston ring (108).
3. Place the ball (107) on the seat of the housing (104). Install the displacement rod (103) over the top of the connecting rod so the holes in both parts align. Secure with the retaining pin (106) and o-rings (105*).
4. Slide the displacement rod up through the cylinder so it protrudes from the packing housing (114).
5. Slide the valve stop (117) and bearing (118*) onto the connecting rod (104). Install the packings (120*) in the poppet (119) and slide onto the priming piston rod.
6. Install the gasket (116*) on the inlet valve housing (102). Secure the housing to the cylinder (101) with the clamp (115). Slide the priming piston (121) onto the rod. Install the retaining pin (122) in the connecting rod (104).

Reconnect the Pump

1. Slide the assembled lower into position on the tie rod plate and reattach the clamp.
2. **Ram-mounted pumps:** Reconnect ram air lines. Lower the pump onto the ram base or drum and reattach the clamp.
3. Hold the motor shaft up with one hand. With your other hand, put the coupling nut on the rod.
4. Put the coupling collars into the coupling nut so large flanges point upward.
5. Gently let the motor shaft drop onto the rod. Tighten the coupling nut securely. A Graco spanner wrench tool (p/n 112887) is available.
6. Connect the remaining air and fluid hoses and the ground wire.

Double-Ball Service

Disconnect the Pump



1. Remove the pump from the fluid container. Operate it at a slow rate to pump out as much fluid as possible.
2. Follow the **Pressure Relief Procedure**, page 8.
3. Remove the air and fluid hoses from the pump. **Ram-mounted pumps:** leave ram air connected for now.

4. Hold the reducer fitting with a wrench. Use a spanner wrench (T)* to loosen the coupling nut.
*A Graco spanner wrench tool (p/n 112887) is available.

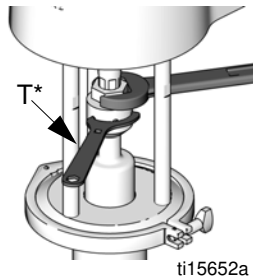

5. Lower the coupling nut enough to remove the coupling collars.

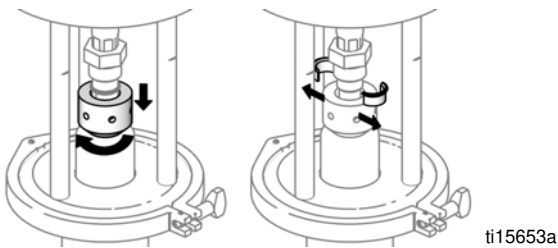

6. Remove the clamp holding the pump base to the ram or drum. **Ram-mounted pumps:** Use the ram to lift the air motor. Disconnect air lines.
7. See FIG. 5. Release the clamp (C) holding the displacement pump (L) to the tie rod plate (P).
8. Carry the displacement pump to the bench for service.

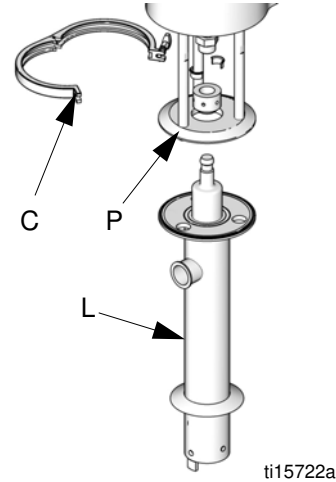

FIG. 5. Disconnect the displacement pump

Disassemble the Pump

NOTE: Pump Repair Kits are available. Purchase the kit separately. See the Parts list for your displacement pump on pages 23 and 25 to select the correct kit for your displacement pump. Kit parts are marked with an *.

1. **Displacement Pump Models 24G754, 24G755, and 24G756:** See FIG. 6. Remove the inlet valve housing (102) by removing the retaining pins (128, 129) and the o-rings (105) and pulling the valve out of the cylinder (101). Disassemble the valve. Clean and inspect the parts.

Displacement Pump Models 24G757 and 24G758: Remove the clamp (115), gasket (116), and elbow (125, Model 24G758 only, see page 24).

2. Push the displacement rod (103) out through the bottom of the cylinder (101). Remove the piston housing (123) by removing the retaining pin (106) and the o-rings (105) and pulling the piston from the displacement rod. Disassemble, clean and inspect the parts.
3. Take the packing housing (114) out of the cylinder (101) and remove the bearing (112), packing (113), and o-ring (110).
4. Clean and inspect all parts. Refer to the **Cleaning Procedure** on page 9. Replace the parts as necessary.

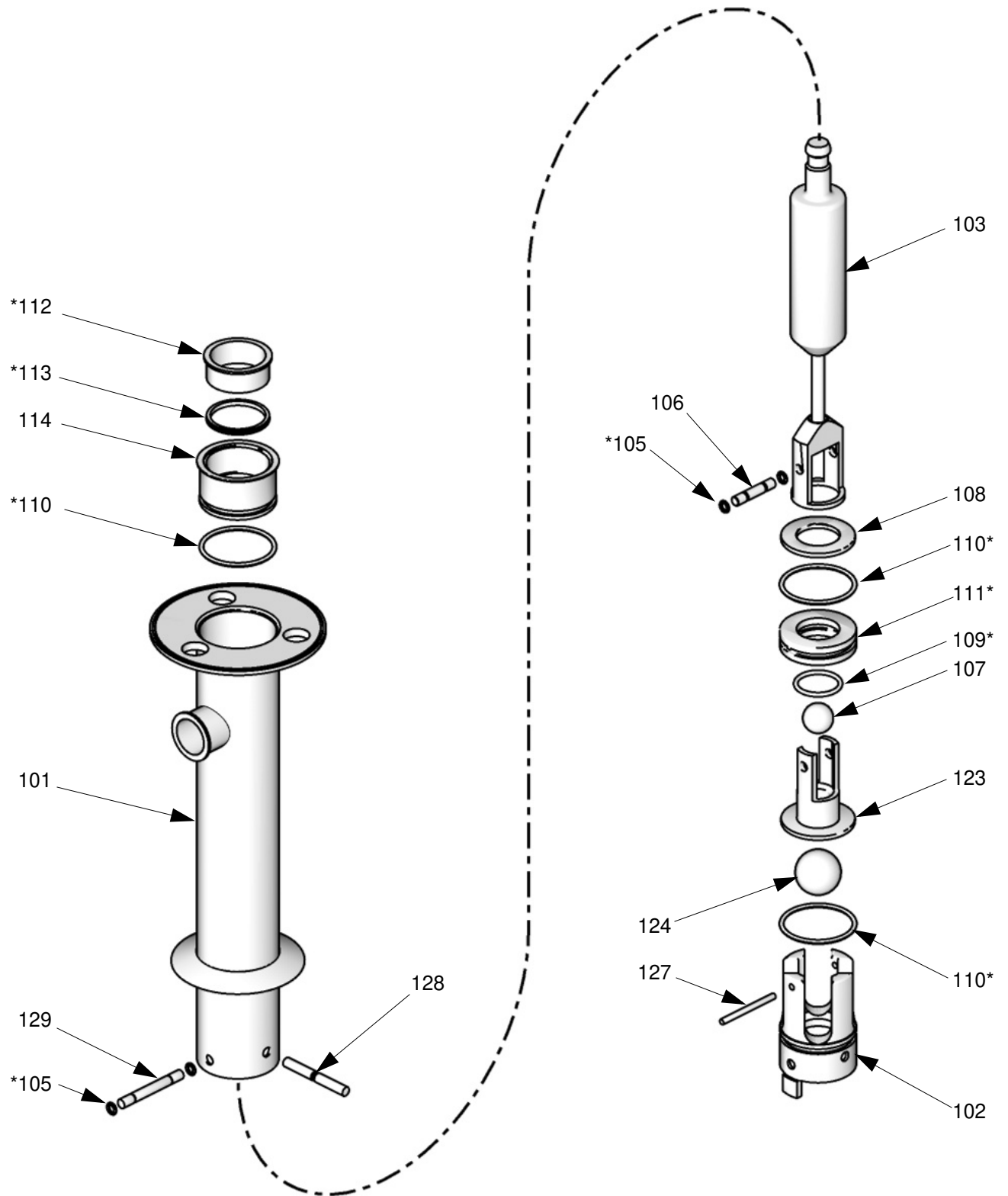

ti15723a

FIG. 6. Double-ball pump assembly

Reassemble After Cleaning

NOTE: Any damaged rubber parts **must** be replaced as they could harbor microorganisms that can contaminate the fluid.

NOTE: Lubricate the o-rings, throat packing, and piston seal with waterproof appropriate sanitary lubricant when reassembling.

1. Install the v-block packing (113*) and bearing (112*) in the packing housing (114). The lips of the packing must face down into the housing, and the lip of the bearing must face up. Install the o-ring (110*) on the outside of the housing. Place the packing housing in the top of the cylinder.
2. Install the o-rings (109*, 110*) on the piston seal (111*). Install the seal on the piston valve housing. Install the piston ring (108).
3. Place the ball (107) on the seat of the piston housing (123). Install the housing in the displacement rod (103) so the holes in both parts align. Secure with the retaining pin (106) and o-rings (105*).
4. Slide the displacement rod up through the cylinder (101) so it protrudes from the packing housing (114).
5. Place the ball (124) on the seat of the inlet housing (102). Install the o-ring (110*) on the outside of the housing. Slide the valve stop (127) into the holes in the housing.
6. Insert the inlet valve housing (102) into the cylinder (101), aligning the holes in both parts. Secure with the retaining pins (128, 129) and o-rings (105*).





Reconnect the Pump

1. Slide the assembled lower into position on the tie rod plate and reattach the clamp.
2. **Ram-mounted pumps:** Reconnect ram air lines. Lower the pump onto the ram base or drum and reattach the clamp.
3. Hold the motor shaft up with one hand. With your other hand, put the coupling nut on the rod.
4. Put the coupling collars into the coupling nut so large flanges point upward.
5. Gently let the motor shaft drop onto the rod. Use a spanner wrench to tighten the coupling nut securely. A Graco spanner wrench tool (p/n 112887) is available.
6. Connect the remaining air and fluid hoses and the ground wire.

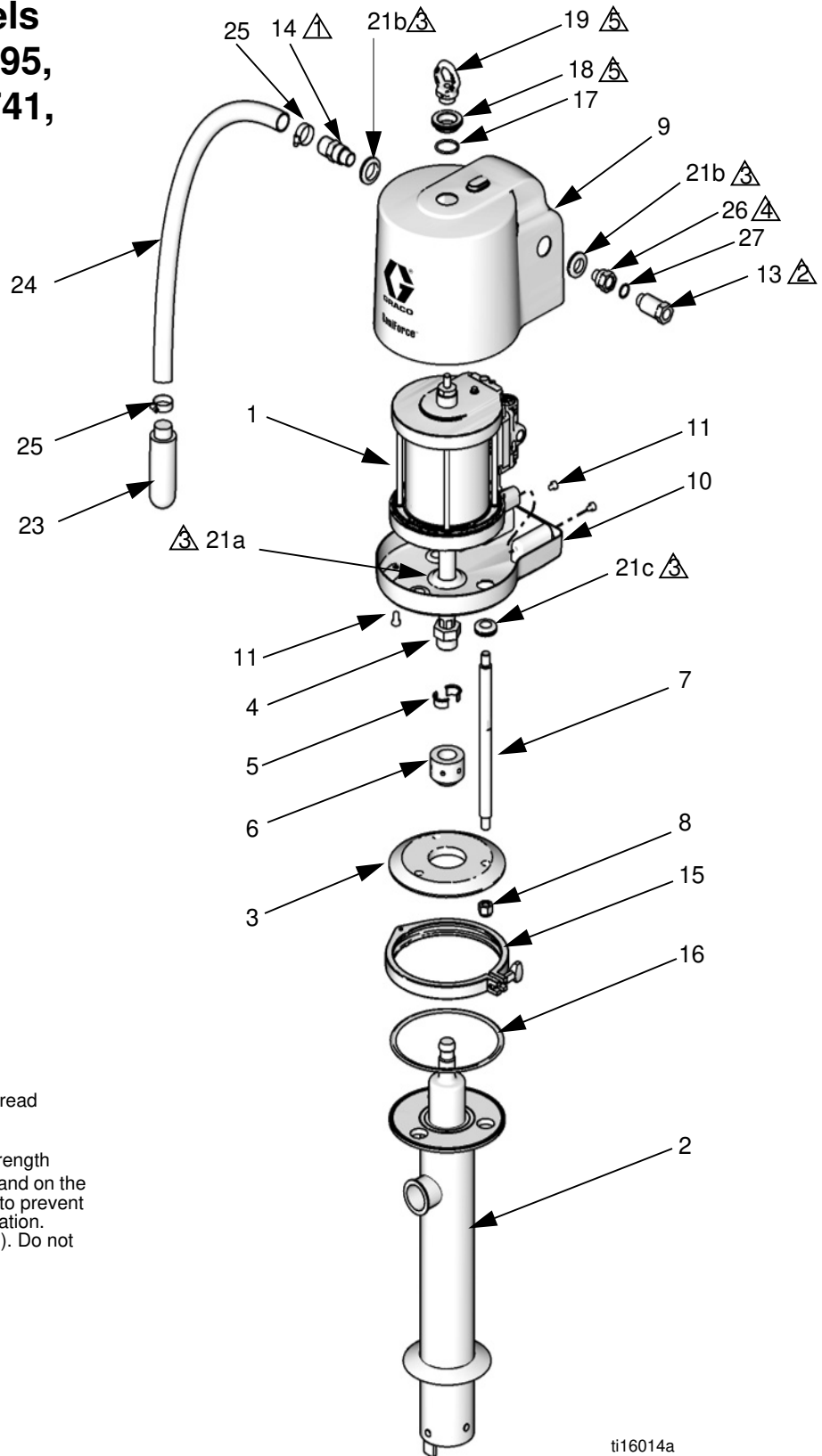
Parts

Complete Pump Models 24E831, 24E833, 24F195, 24F196, 24F197, 24G741, and 24G742



-  Apply PTFE tape to threads.
-  Hand tighten only.
-  Apply sanitary lubricant.
-  Apply medium-strength (blue) thread locker.
-  Apply an appropriate medium-strength thread locker on the lift ring (19) and on the nut (18) every time it is installed to prevent it from coming loose during operation. Torque to 30-36 ft-lb (41-49 N•m). Do not overtighten.

ti16014a

Complete Pump Models 24E831, 24E833, 24F195, 24F196, 24F197, 24G741, and 24G742

Ref.	Part	Description	Qty.	Ref.	Part	Description	Qty.
1	24G786	MOTOR, SaniForce; 6.0 in.; see manual 3A1211	1	10	16G383	SHROUD, lower; includes fasteners (Ref. 11) and grommets (Ref. 21)	1
2		DISPLACEMENT PUMP	1	11	118134	SCREW, cap; M8 x 1.25, sst	4
	24G759	Used on Pump Model 24G741; see page 20		13	24G862	FITTING, air inlet, 1/2 npt, Includes Ref. 27	1
	24G754	Used on Pump Model 24G742; see page 22		14	16C946	FITTING, 3/4 npt	1
	24G760	Used on Pump Model 24E831; see page 20		15	512607	CLAMP, 8 in. tri-clamp	1
	24G755	Used on Pump Model 24E833; see page 22		16	512606	GASKET, tri-clamp, buna-N	1
	24G756	Used on Pump Model 24F195; see page 22		17	165053	O-RING, PTFE	1
	24G758	Used on Pump Model 24F196; see page 24		18	16C306	NUT, hand	1
	24G757	Used on Pump Model 24F197; see page 24		19‡	16C009	RING, lift	1
3	624248	PLATE, tie rod	1	20▲	280574	LABEL, warning, not shown	1
4	16A939	COUPLER	1	21	-----	GROMMET; see Kits	6
5	184130	COLLAR, coupling	2	22‡	680454	GASKET; not shown	1
6	626045	COUPLING	1	23‡	512914	MUFFLER; see Kits	1
7	16A946	TIE ROD, 12.52 in. (318 mm) between shoulders	3	24‡	-----	HOSE, exhaust; see Kits	1
8	102216	NUT, lock, 5/8-11, sst	3	25‡	101818	CLAMP, hose; see Kits	2
9	16G381	SHROUD, upper; includes grommets (Ref. 21)	1	26	16G084	FITTING, air inlet, 1/2 npt	1
				27	166702	O-RING, air inlet, buna-n	1
				28‡	102218	CLAMP, toggle; not shown	1

▲ Replacement Danger and Warning labels, tags, and cards are available at no cost.

‡ Used on Models 24E831, 24E833, 24F195, 24F196, and 24F197 only. These parts are not used with Models 24G741 and 24G742.

Kits

Muffler Kit 16G390

Ref.	Part	Description	Qty.
23	512914	MUFFLER, polyethylene	2

Exhaust Assembly Kit 16G389

Ref.	Part	Description	Qty.
23	512914	MUFFLER, polyethylene	1
24	-----	HOSE, exhaust, 6 ft.	1
25	101818	CLAMP, hose	2

Lower Shroud Fastener Kit 16G432

Ref.	Part	Description	Qty.
11	118134	SCREW, cap, M8 x 1.25, sst	4

Grommet Kit 16G385

Ref.	Part	Description	Qty.
21a*	-----	GROMMET, air motor piston rod	1
21b	-----	GROMMET, air fitting	2
21c	-----	GROMMET, tie rod	3

* Order Kit 16G384 for qty. 3 of the piston rod grommet.

Spanner Wrench

Ref.	Part	Description	Qty.
	112887	WRENCH, spanner	1

Priming Piston Displacement Pump Models 24G759 and 24G760

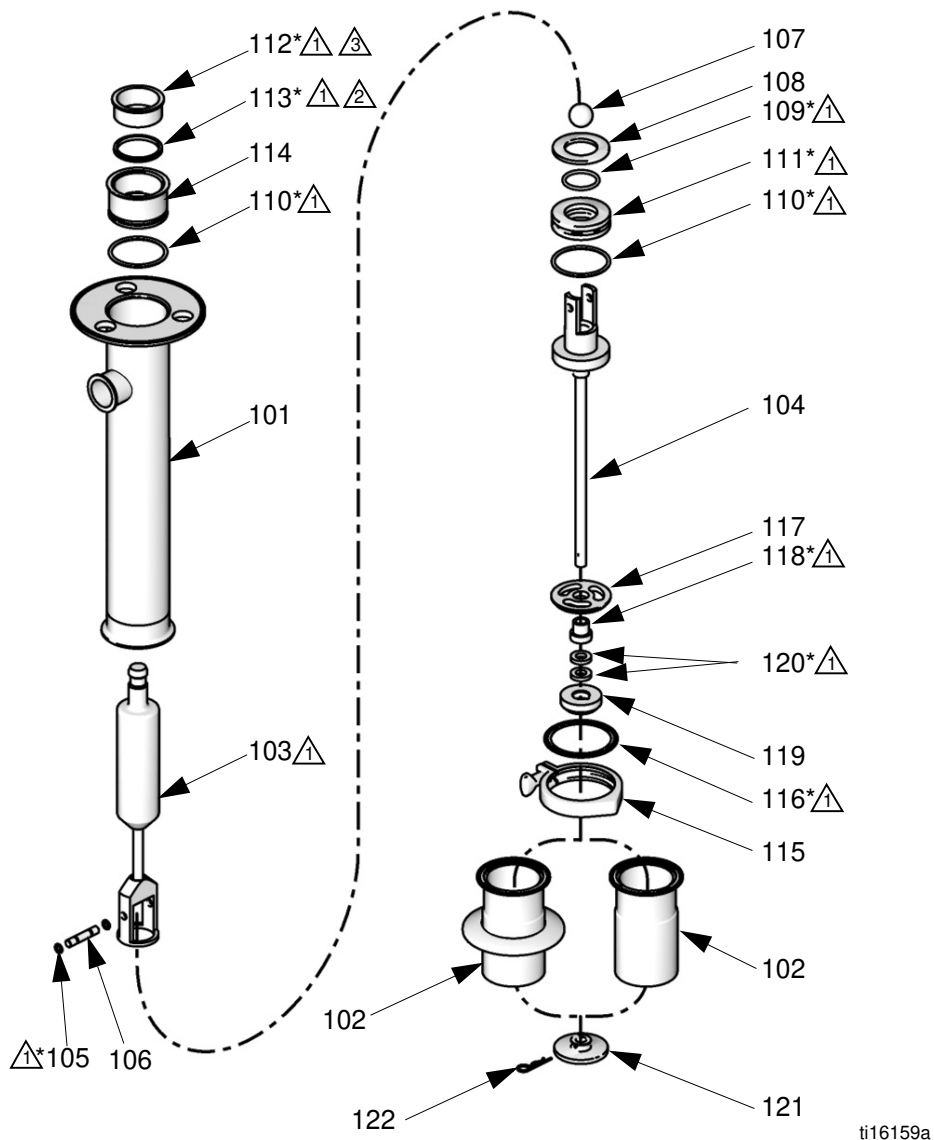

ti16159a

△¹ Apply appropriate waterproof, sanitary lubricant.

△³ Bearing lip must face UP.

△² Throat v-cup lips must face DOWN.

Priming Piston Displacement Pump Models 24G759 and 24G760

Ref.	Part	Description	Qty.	Ref.	Part	Description	Qty.
101	16G433	CYLINDER, pump	1	112*	624247	BEARING, throat, PTFE	1
102		HOUSING, inlet valve	1	113*	512605	PACKING; UHMWPE	1
	16C191	Used on Model 24G759		114	624246	HOUSING, throat	1
	626580	Used on Model 24G760		115	510490	CLAMP, tri-clamp, 4 in.	1
103	965531	ROD, displacement	1	116*	513548	GASKET, tri-clamp, 4 in., buna-n	1
104	570081	ROD, connecting	1	117	626578	STOP, inlet valve	1
105*	16G659	O-RING, buna-n	2	118*	626579	BEARING, pump	1
106	624244	PIN, ball stop	1	119	626582	POPPET, inlet valve	1
107	512603	BALL, 1 1/2 in. UHMWPE	1	120*†	552060	PACKING, inlet valve, neoprene	2
108	624243	RING, piston	1	121	626581	PISTON, priming	1
109*	512602	O-RING, buna-n	1	122	626584	PIN, retaining	1
110*	512589	O-RING, buna-n	2				
111*	624242	GLAND, piston, UHMWPE	1				

* Parts included in Repair Kit 24G552.

† Available in FKM material, PN 17S592 (2 required),
or Buna-N material, PN 17S593 (2 required)

Double-Ball Displacement Pump Models 24G754, 24G755, and 24G756

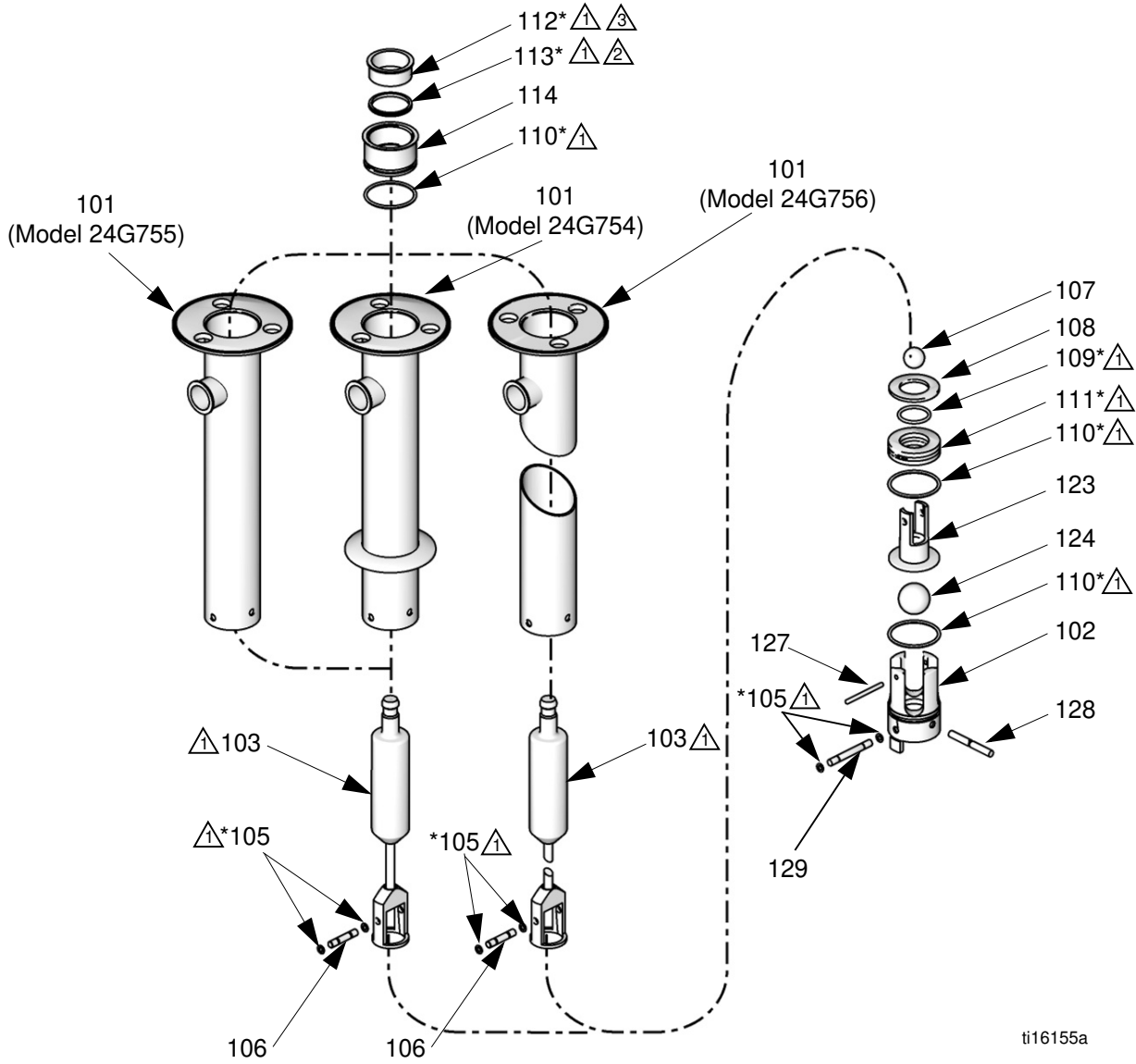

ti16155a

△1 Apply appropriate waterproof, sanitary lubricant. △3 Bearing lip must face UP.

△2 Throat v-cup lips must face DOWN.

Double-Ball Displacement Pump Models 24G754, 24G755, and 24G756

Ref.	Part	Description	Qty	Ref.	Part	Description	Qty
101		CYLINDER, pump	1	111*	624242	GLAND, piston, UHMWPE	1
	16F911	Used on Model 24G756		112*	624247	BEARING, throat, PTFE	1
	16G434	Used on Model 24G754		113*	512605	PACKING; UHMWPE	1
	16G435	Used on Model 24G755		114	624246	HOUSING, throat	1
102	624222	HOUSING, inlet	1	123	624241	HOUSING, piston	1
103		ROD, piston	1	124	512601	BALL, 2 1/4 in., UHMWPE	1
	16A940	Used on Model 24G756		127	624229	PIN, ball stop, inlet	1
	965531	Used on Models 24G754 and 24G755		128	624689	PIN, retaining, inlet, notched	1
105*	16G659	O-RING, buna-n	4	129	624230	PIN, retaining, inlet	1
106	624244	PIN, ball stop, piston	1				
107	512603	BALL, 1 1/2 in., UHMWPE	1				
108	624243	RING, piston	1				
109*	512602	O-RING, buna-n	1				
110*	512589	O-RING, buna-n	3				

* Parts included in Repair Kit 24G551.

Double-Ball Displacement Pump Models 24G757 and 24G758

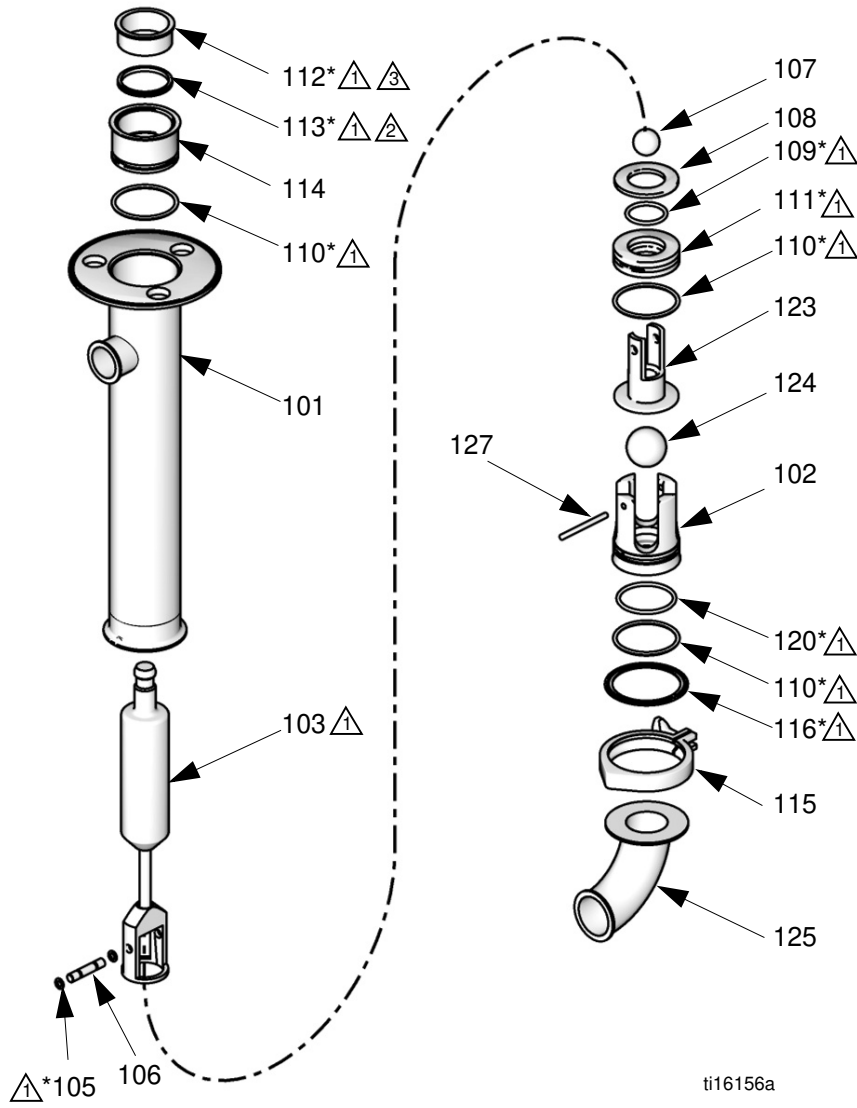

- △ Apply appropriate waterproof, sanitary lubricant.
- △ Bearing lip must face UP.
- △ Throat v-cup lips must face DOWN.

Double-Ball Displacement Pump Model 24G757

Ref	Part	Description	Qty.
101	16D320	CYLINDER, pump	1
102	626013	HOUSING, inlet valve	1
103	965531	ROD, displacement	1
105*	16G659	O-RING, buna-n	2
106	624244	PIN, ball stop, piston	1
107	512603	BALL, 1 1/2 in., UHMWPE	1
108	624243	RING, piston	1
109*	512602	O-RING, buna-n	1
110*	512589	O-RING, buna-n	3
111*	624242	GLAND, piston, UHMWPE	1
112*	624247	BEARING, throat, PTFE	1
113*	512605	PACKING; UHMWPE	1
114	624246	HOUSING, throat	1
115	510490	CLAMP, tri-clamp, 4 in.	1
116*	513548	GASKET, tri-clamp, 4 in., buna-n	1
120*	551314	O-RING; silicone; used on Model 24G757 only	1
123	626014	HOUSING, piston	1
124	512601	BALL, 2 1/4 in., UHMWPE	1
127	624229	PIN, ball stop, inlet	1

* Parts included in Repair Kit 24G554.

Double-Ball Displacement Pump Model 24G758

Ref	Part	Description	Qty.
101	16D320	CYLINDER, pump	1
102	625049	HOUSING, inlet valve	1
103	965531	ROD, displacement	1
105*	514315	O-RING, FKM	2
106	624244	PIN, ball stop, piston	1
107	514319	BALL, 1 1/2 in., PTFE	1
108	624243	RING, piston	1
109*	514318	O-RING, FKM	1
110*	514316	O-RING, FKM	3
111*	625562	GLAND, piston, PTFE	1
112*	624247	BEARING, throat, PTFE	1
113*	512605	PACKING; UHMWPE	1
114	624246	HOUSING, throat	1
115	510490	CLAMP, tri-clamp, 4 in.	1
116*	514322	GASKET, tri-clamp, 4 in., FKM	1
123	624241	HOUSING, piston	1
124	514317	BALL, 2 1/4 in., PTFE	1
125	513545	ELBOW, fluid inlet; used on Model 24G758 only	1
127	624229	PIN, ball stop, inlet	1

* Parts included in Repair Kit 24G553.

Dimensions

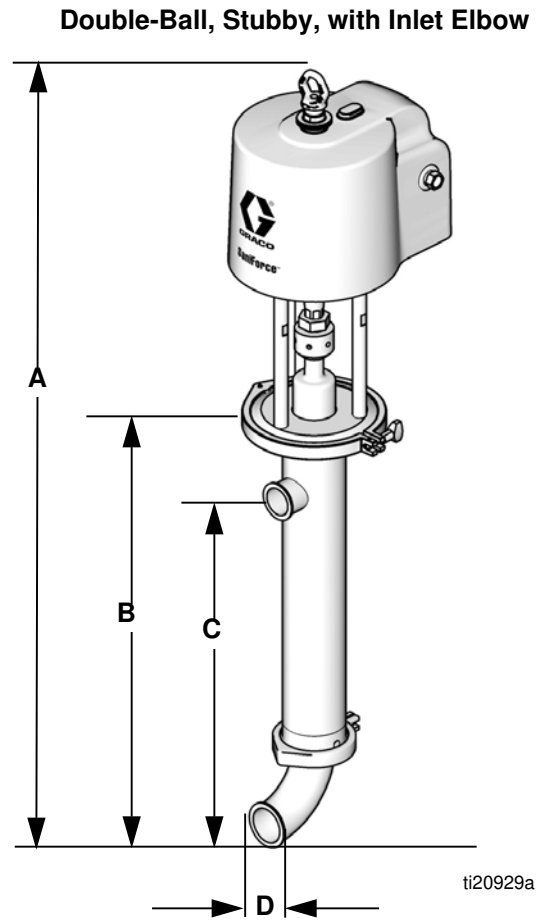
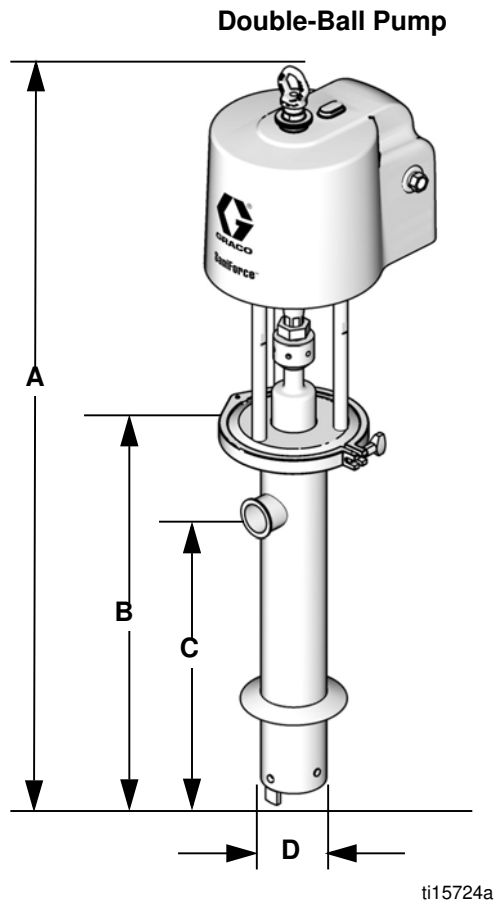

Model	Weight lb (kg)	Pump Type	Pump Length Description	A in. (cm)	B in. (cm)	C in. (cm)	D in. (cm)
24G742	95 (43)	Double Ball	Stubby, with Flange for Ram	51.5 (131)	25.9 (66)	20.4 (52)	4 (10.2)
24E833	91 (41)	Double Ball	Stubby				4 (10.2)
24F196	93 (42)	Double Ball	Stubby, with Inlet Elbow	56.3 (143)	30.7 (78)	25.2 (64)	2.5 in. Tri-clamp
24F197	91 (41)	Double Ball	Stubby	50.4 (128)	24.8 (63)	19.3 (49)	4 (10.2)
24F195	119 (54)	Double Ball	Drum Length	67.9 (172)	42.3 (107)	36.8 (93)	4 (10.2)

Priming Piston Pump

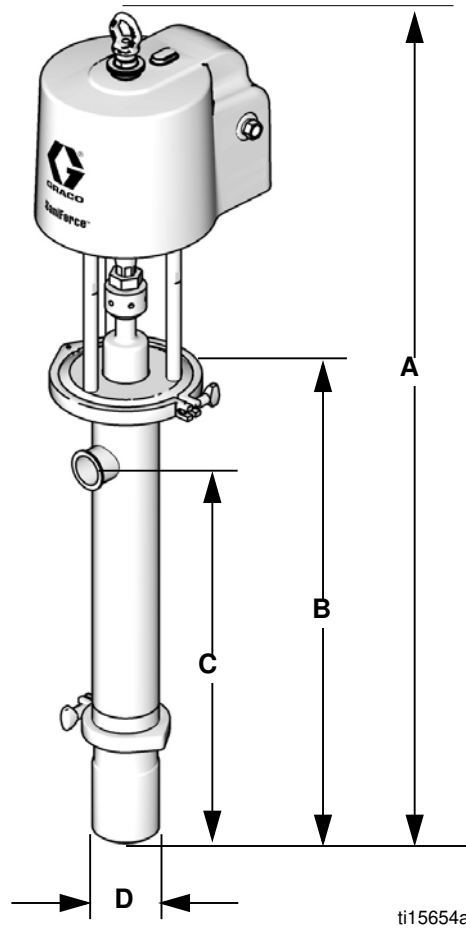

ti15654a

Model	Weight lb (kg)	Pump Type	Pump Length Description	A in. (cm)	B in. (cm)	C in. (cm)	D in. (cm)
24G741	99 (45)	Priming Piston	Drum Length, with Flange for Ram	57.0 (145)*	31.3 (80)*	25.9 (66)*	4 (10.2)
24E831	95 (43)	Priming Piston	Drum Length				4 (10.2)

* Add 2.9 in. (7.4 cm) for priming piston models to allow for full extension of the priming piston rod.

Performance Chart

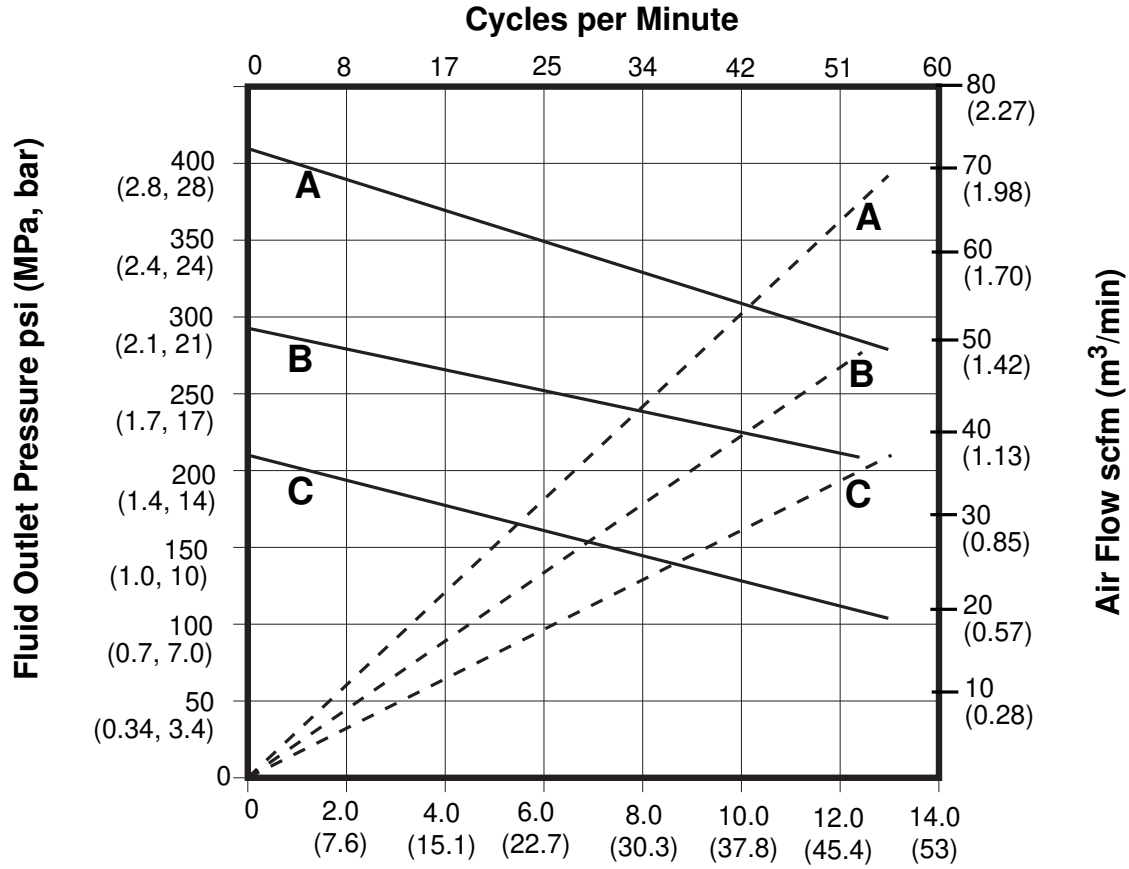

Fluid Flow gpm (lpm) tested in No. 10 weight oil

KEY

A	= 80 psi (0.5 MPa, 5.5 bar)
B	= 60 psi (0.4 MPa, 4 bar)
C	= 40 psi (0.3 MPa, 3 bar)
—	= fluid flow
- - -	= air consumption

Technical Data

Maximum Fluid Working Pressure	410 psi (2.9 MPa, 28.7 bar)
Maximum Air Inlet Pressure	80 psi (0.6 MPa, 5.5 bar)
Maximum Recommended Pump Speed	60 cycles/min, 14 gpm (53 liters/min) delivery
Maximum Size Pumpable Solids	1/4 in. (6.4 mm)
Air Consumption	<i>See Performance Chart, page 28</i>
Pump Cycles per Gallon (3.8 Liters)	4.3
Ratio	5:1
Maximum operating temperature	140°F (60°C)
Maximum ambient temperature (air motor)	120°F (49°C)
Air inlet	1/2 in. npt(f)
Air Exhaust	3/4 in. npt(m)
Pump Inlet Type	
24E833, 24F195, and 24F197	4 in. (10.2 cm) Slotted
24F196	90 degree elbow, 2.5 in. (6.3 cm) Tri-clamp®
24E831	4 in. (10.2 cm) Priming Piston
24G741	4 in. (10.2 cm) Priming Piston with flange for 6 in (15.2 cm) Clamp
34G742	4 in. (10.2 cm) Slotted with flange for 6 in (15.2 cm) Clamp
Fluid Outlet	2 in. Tri-clamp®
Weight	<i>See Dimensions, page 26</i>
Wetted Parts	316 Stainless Steel, Buna-N, UHMWPE, PTFE, Poly- chloroprene*, Nylon*
	* priming piston pumps only
Sound data	
Sound power*	77.5 dBA
Sound pressure**	70.7 dBA

* Sound power at 70 psi (0.48 MPa, 4.8 bar), 20 cpm. Sound power measured per ISO-9614-2.

** Sound pressure was tested 3.28 feet (1 m) from equipment.

California Proposition 65

CALIFORNIA RESIDENTS

 **WARNING:** Cancer and reproductive harm – www.P65warnings.ca.gov.

Graco Standard Warranty

Graco warrants all equipment referenced in this document which is manufactured by Graco and bearing its name to be free from defects in material and workmanship on the date of sale to the original purchaser for use. With the exception of any special, extended, or limited warranty published by Graco, Graco will, for a period of twelve months from the date of sale, repair or replace any part of the equipment determined by Graco to be defective. This warranty applies only when the equipment is installed, operated and maintained in accordance with Graco's written recommendations.

This warranty does not cover, and Graco shall not be liable for general wear and tear, or any malfunction, damage or wear caused by faulty installation, misapplication, abrasion, corrosion, inadequate or improper maintenance, negligence, accident, tampering, or substitution of non-Graco component parts. Nor shall Graco be liable for malfunction, damage or wear caused by the incompatibility of Graco equipment with structures, accessories, equipment or materials not supplied by Graco, or the improper design, manufacture, installation, operation or maintenance of structures, accessories, equipment or materials not supplied by Graco.

This warranty is conditioned upon the prepaid return of the equipment claimed to be defective to an authorized Graco distributor for verification of the claimed defect. If the claimed defect is verified, Graco will repair or replace free of charge any defective parts. The equipment will be returned to the original purchaser transportation prepaid. If inspection of the equipment does not disclose any defect in material or workmanship, repairs will be made at a reasonable charge, which charges may include the costs of parts, labor, and transportation.

THIS WARRANTY IS EXCLUSIVE, AND IS IN LIEU OF ANY OTHER WARRANTIES, EXPRESS OR IMPLIED, INCLUDING BUT NOT LIMITED TO WARRANTY OF MERCHANTABILITY OR WARRANTY OF FITNESS FOR A PARTICULAR PURPOSE.

Graco's sole obligation and buyer's sole remedy for any breach of warranty shall be as set forth above. The buyer agrees that no other remedy (including, but not limited to, incidental or consequential damages for lost profits, lost sales, injury to person or property, or any other incidental or consequential loss) shall be available. Any action for breach of warranty must be brought within two (2) years of the date of sale.

GRACO MAKES NO WARRANTY, AND DISCLAIMS ALL IMPLIED WARRANTIES OF MERCHANTABILITY AND FITNESS FOR A PARTICULAR PURPOSE, IN CONNECTION WITH ACCESSORIES, EQUIPMENT, MATERIALS OR COMPONENTS SOLD BUT NOT MANUFACTURED BY GRACO. These items sold, but not manufactured by Graco (such as electric motors, switches, hose, etc.), are subject to the warranty, if any, of their manufacturer. Graco will provide purchaser with reasonable assistance in making any claim for breach of these warranties.

In no event will Graco be liable for indirect, incidental, special or consequential damages resulting from Graco supplying equipment hereunder, or the furnishing, performance, or use of any products or other goods sold hereto, whether due to a breach of contract, breach of warranty, the negligence of Graco, or otherwise.

FOR GRACO CANADA CUSTOMERS

The Parties acknowledge that they have required that the present document, as well as all documents, notices and legal proceedings entered into, given or instituted pursuant hereto or relating directly or indirectly hereto, be drawn up in English. Les parties reconnaissent avoir convenu que la rédaction du présente document sera en Anglais, ainsi que tous documents, avis et procédures judiciaires exécutés, donnés ou intentés, à la suite de ou en rapport, directement ou indirectement, avec les procédures concernées.

Graco Information

For the latest information about Graco products, visit www.graco.com.

For patent information, see www.graco.com/patents.

TO PLACE AN ORDER, contact your Graco distributor or call to identify the nearest distributor.

Phone: 612-623-6921 **or Toll Free:** 1-800-328-0211 **Fax:** 612-378-3505

*All written and visual data contained in this document reflects the latest product information available at the time of publication.
Graco reserves the right to make changes at any time without notice.*

Original instructions. This manual contains English. MM 3A0734

Graco Headquarters: Minneapolis

International Offices: Belgium, China, Japan, Korea

GRACO INC. AND SUBSIDIARIES • P.O. BOX 1441 • MINNEAPOLIS MN 55440-1441 • USA

Copyright 2011, Graco Inc. All Graco manufacturing locations are registered to ISO 9001.

www.graco.com

Revision S, December 2021