

IMMERSIBLE PUMPS FOR INDUSTRY

COMPACT TANK
TOP SOLUTIONS
FOR DEMANDING
APPLICATIONS



be
think
innovate

GRUNDFOS 

RENOWNED FOR THEIR **RELIABILITY** AND **PRECISION**

When you choose a Grundfos immersible pump, you get a pump used by the metal processing industry for decades that has proven its worth. In addition, the Grundfos range of MTR, MTH, MTA, MTD and MTS immersible pumps include sizes and material variants that fit general industry applications, bringing their renowned reliability and precision to an even wider number of application areas.

A Grundfos immersible pumping solution will optimise your processes, increase efficiency, and lower your energy consumption. All pumps are available for 50 Hz and/or 60 Hz operation and global voltages.

Stainless steel variants

Grundfos offers a comprehensive range of stainless-steel pumps providing many benefits, for example superior corrosion resistance and an easy-to-clean surface. Immersible pumps available in stainless steel include the MTH and the MTR/MTRE.

The chromium oxide film offers surface protection, and the addition of other elements such as nickel, molybdenum and nitrogen give the steel special properties. All Grundfos stainless steel products meet EN 1.4401 and EN 1.4301 stainless steel grades.



MTDE

MTA

MTH

MTR

COMPACT **TANK TOP SOLUTIONS** FOR DEMANDING APPLICATIONS

The MTR, MTH, MTA and MTD vertical multi-stage centrifugal pumps and the MTS screw pumps are designed for mounting on top of tanks with the pump unit immersed in the liquid to be pumped. The pumps consist of two main components: The motor and the pump unit. Depending on the solution required, the length of the immersed pump unit can vary.

With a range capable of delivering from 0.5 to 102 m³/h at pressures of up to 100 bar where required, there is a Grundfos immersible pump for every process.

Applications where Grundfos immersible pumps are used include:

- **Machine tool**

Delivers the pressure and flow of coolant for the precise cooling and lubrication required to obtain a good finish and tolerances for machined parts

- **Temperature control**

Exact temperature control, also for precision applications with temperature fine-tuned within a margin of 0.01 °C

- **Wash & clean**

Ideal for all industrial washing requirements where compact installation is required, and for dealing with different kinds of alkaline media

- **Filtration**

Pumps for low pressure with allowance for particles up to 10 mm and pumps for general low and high pressure filtration systems

- **Water treatment**

Ideal as a washdown pump for filter cleansing in disc and drum filters for municipal wastewater treatment and industrial water treatment, and for water treatment in Aquaculture

SEE WHAT GRUNDFOS IMMERSIBLE PUMPS HAVE TO OFFER:

- Compact, tank top design
- Easy installation
- Flexible immersible length
- Broad product range
- Wide performance range
- 50 Hz and/or 60 Hz operation
- Stainless steel parts, tailored to the application
- Motors for every need
- High efficiency
- Reliability
- Service-friendly



MTRE

MTSE

MTR

The **MTR RANGE**

– where power is required

The MTR range offers a broad range of high efficiency pumps of different immersible length for varying flow and pressure requirements of up to 102 m³/h (1700 l/min) and pressures up to 35 bar. MTR pumps are available as a customised solution in cast iron or stainless steel and in number of variants.

In addition to machine tool, wash & clean applications, and the circulation of cooling liquids, MTR pumps are also used as condensate or filter pumps. They are well suited for water treatment applications as well.

The MTR range is also available:

- With drainage back to tank solution
- As completely enclosed for temperatures up to 120 °C
- For horizontal installation in the side of the tank
- With explosion-proof motors, ATEX-approved pump/motors

MOTOR

Standard IE3 motor (MTR) and with an integrated frequency converter for IE5 motors (MTRE) available for global voltage with single and three-phase motors. Motor protection from Klixon, PTC and PT100 or the frequency converter. Enclosure class IP55 as standard. Available in a tropicalised variant for condensing environments

PIPE CONNECTIONS

Internal thread: Rp, G, NPT
Flange connection: Grundfos square flange, EN/DIN, JIS and ANSI

VARIABLE LENGTH

To reach the exact depth of tank, the immersible length can be extended up to 1.5 m, depending on pump size



APPROVALS

Meets current motor and pump efficiency requirements applicable in your market such as the global MEPS (Minimum Energy Performance Standards) for the motor and the Ecodesign requirements for rotodynamic water pumps defined by the Minimum Efficiency Index (MEI).



MATERIALS

Available in three material variants – cast iron and two different stainless steel grades, covering everything from clean water, coolant to chemical applications

MTR:

Flow rate:	max 102 m ³ /h (1700 l/min)
Head:	max 250 m
Motor:	0.37-45 kW
Liquid temp.:	-10 °C to +90 °C (+120 °C)
Pump sizes:	11

SEAL SOLUTION

Grundfos offers a wide range of balanced cartridge shaft seals with different seal faces such as Silicon Carbide, Carbon and Tungsten Carbide to handle almost any industrial liquid. Drainage back to tank solution (see page 6)

INLET

Fitted with a suction strainer that prevents large solid particles from entering and damaging the pump. The size of the passage in the strainer and the impeller depends on the pump size. The special priming screw allows for liquid levels down to 25 mm

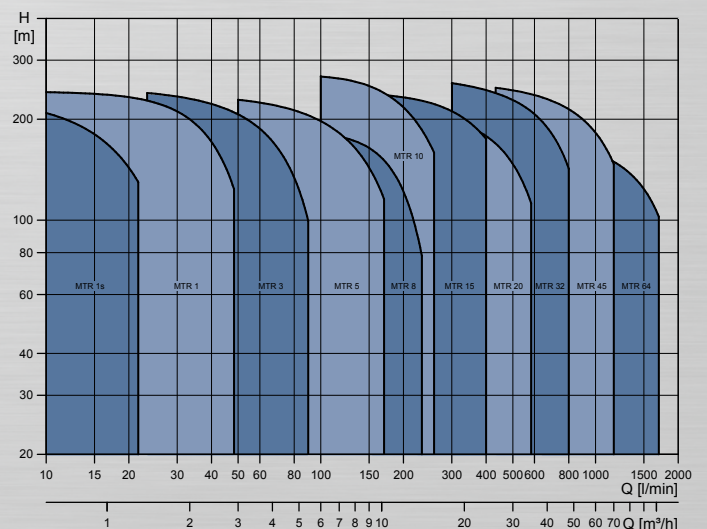

The **MTR RANGE**

– available in the following variants

The MTR range offers a high degree of modularity using standard motors and a range of variants for specific applications.

MTR – DRAINAGE BACK TO TANK

Leak-free pumps are a top priority in any industrial process. Leaking pumps may lead to costly downtime and in turn affect part cost. The MTR DBT (Drainage Back to Tank) pump effectively eliminates that risk, as the liquid remains in the tank where it is supposed to be – even if the shaft seal is worn out and starts to leak. In addition to being leak-free, the MTR DBT pump features an innovative frequency drive motor that reduces energy consumption to reduce further part costs.

- Downtime risk due to leakage is eliminated
- No risk of contamination
- Longer service intervals
- Reduction of part costs
- Non-sticking solution for the shaft seal on startup



MTRE - INTEGRATED FREQUENCY CONVERTER

An E-solution means electronic control and energy savings. This all-in-one solution with pump, motor and integrated frequency converter is packed with intelligent features that makes installation, operation, and service exceptionally easy and performance much more efficient and reliable. The compact, integrated design comes with one drive for use worldwide and complies with all international standards.

- IE5 motor with an integrated frequency converter
- Sensors
- BUS communication
- Pump motor monitoring and protection

MTRE:

Flow rate: max 102 m³/h (1700 l/min)

Head: max 300 m

Motor: 0.37-22 kW

Liquid temp.: -10 °C to +90 °C (+120 °C)

Pump sizes: 11

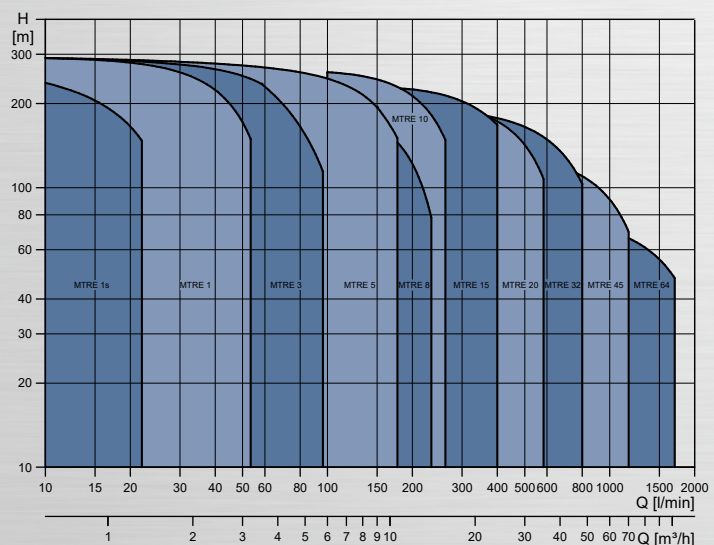

MTRE – RUN AT POWER LIMIT

In certain applications you need to increase pressure as you wish. Customised software allows the pump's RPM to be practically doubled, and the increased speed – referred to as over-synchronous operation – translates into greatly increased pressure and means you get the high pressure you need from a significantly smaller pump. This can be achieved because the pump does not need to perform across the full pump curve. Instead, the software lets the pump operate only within the necessary band with perfect precision.

Run at power limit

- Makes it possible to boost the pressure at lower flows by increasing the frequency
- Makes it possible to use the motor 100% over the full pump curve
- Smaller and more compact pump

MTRE:

Flow rate: max 102 m³/h (1700 l/min)

Head: max 300 m

Motor: 0.37-22 kW

Liquid temp.: -10 °C to +90 °C (+120 °C)

Pump sizes: 11

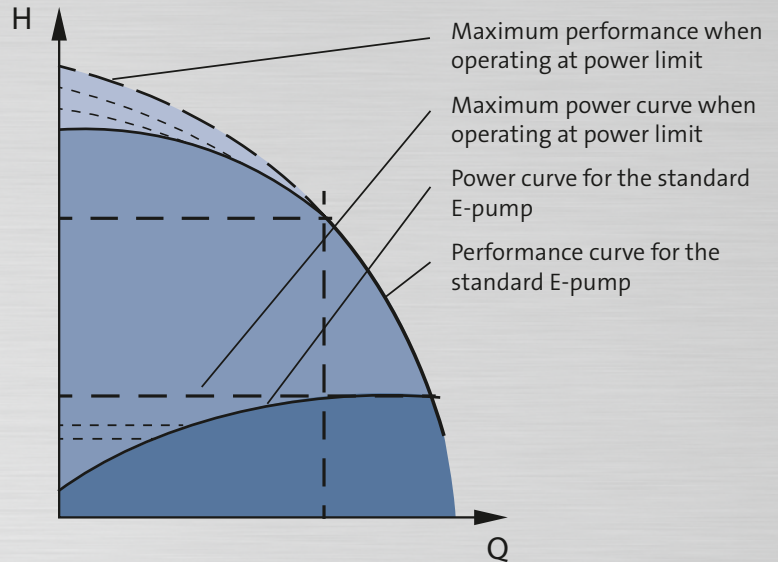

MTRE HIGH PRESSURE

This variant of the MTRE pump with integrated frequency converter is especially designed for applications requiring high pressure. This is obtained by high-speed operation of the motor and reinforced components in the pump, while keeping the general features from standard MTRE pumps.

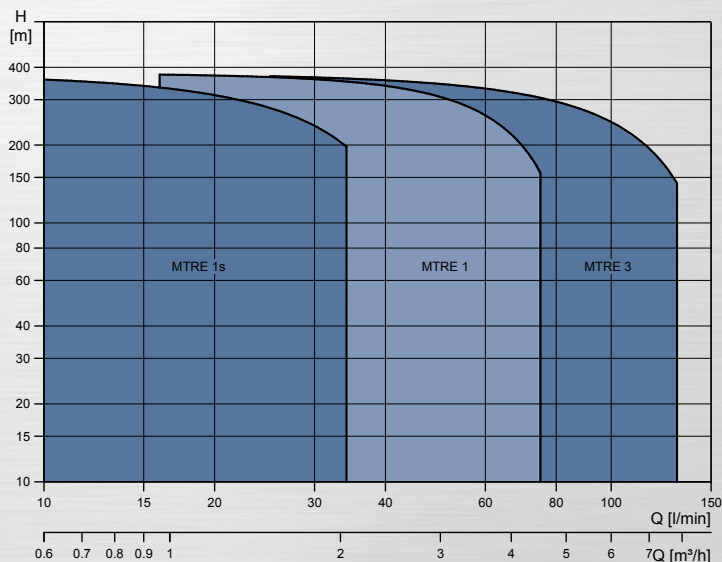

MTRE-HS:

Flow rate: max 8 m³/h (133 l/min)

Head: max 370 m

Motor: 4-7.5 kW

Liquid temp.: -10 °C to +90 °C

Pump sizes: 3



The **MTS RANGE**

– high pressure screw pumps

Grundfos MTS pumps are screw pumps designed for high pressure pumping of cooling lubricants and cutting oils for machine tool applications. These pumps come with various pump sizes and screw pitches to provide the flow and pressure required.

Using MTS screw pumps in machine tool applications, where high pressure is required, results in an increased surface quality and a decreased machining time. The MTS pump is available in different installation variants, such as tank top, in-tank and dry installation, all with a range of connection options.

Pump capabilities:

Flow rate:	max 64.5 m ³ /h (1075 l/min)
Head:	max 100 bar
Motor:	1.5-200 kW
Liquid temp.:	0 °C to +80 °C
Liquid:	Min 2 % oil
Viscosity:	1 to 2000 mm ² /s
Pump sizes:	16

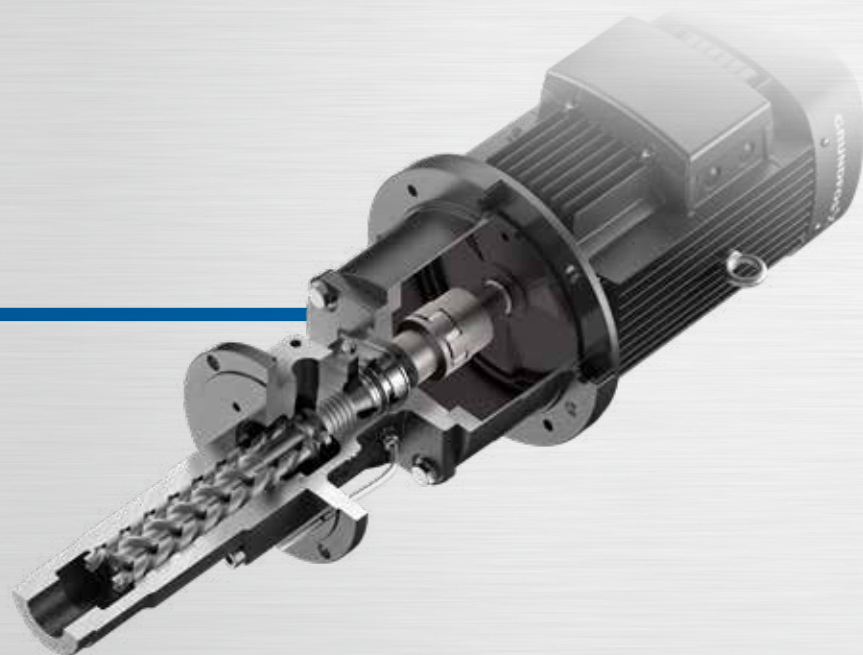
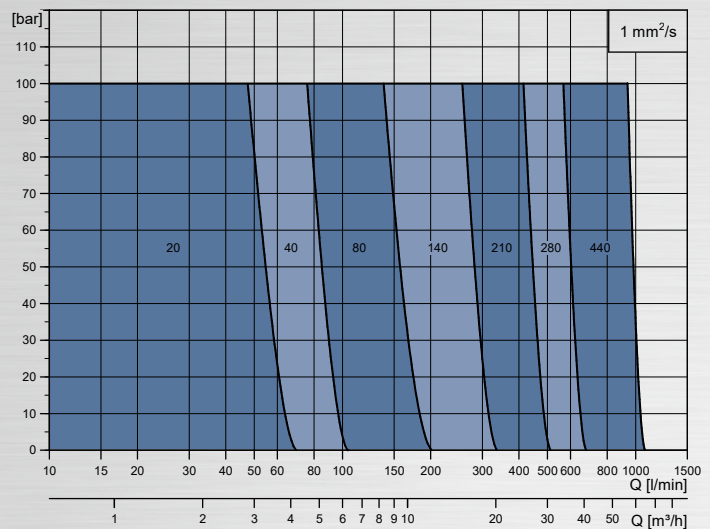

- Motor**
 Standard IE3 motor. Motor protection directly from PTC. IP55 as standard, available in a tropicalised variant for condensing environments.
- Screw pump design**
 High efficiency from the unique three-screw pump design and fine tolerances lead to operation with reduced cooling efforts and low operational costs
- Resistance to high pressure**
 The extra-long pressure compensation piston with labyrinth seal and the hydrostatic axial thrust balancing with special pressure-compensation bushings increase resistance to high pressure
- Maintenance-free sealing**
 Seal ring or mechanical seal according to EN 12796
- Broad range**
 Large number of pump sizes and pitch angles for different flows, and tank top, dry and horizontal installation

- Operation**
 Low vibration and noise level and long lifetime from highly wear-resistant hardened rotor housing and PVD-coated spindles
- Materials**
 Rotor housing: Special hardened, 1200 HV
 Screws: PVD coating, 1200 HV
- Connections**
 Internal thread: Rp
 Flange: SAE
- Leakage inspection tube**
 The transparent tube allows you to see when any leakage starts, enabling you to plan maintenance

APPROVALS

Meets current motor and pump efficiency requirements applicable in your market

MTSE – INTEGRATED FREQUENCY CONVERTER

An E-solution means electronic control and energy savings. This all-in-one solution with pump, motor and integrated frequency converter is packed with intelligent features that makes installation, operation, and service exceptionally easy and performance much more efficient and reliable. The MTSE is a smaller and more compact pump which is designed to run at power limit. This makes it possible to boost the pressure at lower flows by increasing the frequency, and you can also use the motor 100 % over the full pump curve. The compact, integrated design comes with one drive for use worldwide and complies with all international standards.

Pump capabilities:

Flow rate: max 6.9 m³/h (115 l/min)

Head: max 100 bar

Motor: 1.5-11 kW

Liquid temp.: 0 °C to +80 °C

Liquid: Min 2 % oil

Viscosity: 1 to 2000 mm²/s

Pump sizes: 6

- IE5 motor with an integrated frequency converter
- Sensors
- BUS communication
- Pump motor monitoring and protection

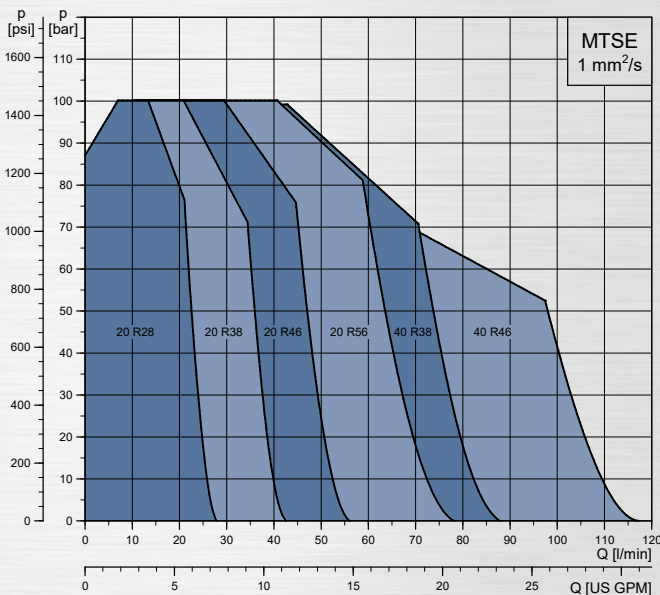

MTS/MTSE PUMP SYSTEM – ALL COMPONENTS FULLY INTEGRATED

Assembled pump system with MTS/MTSE screw pump, mounting plate, pressure relief valve and piping.

- **Fully integrated all-in-one system**
All components, including valves, are preassembled to customer specifications
- **Economical pump operation**
Pump efficiency above 80 % with low heat transfer into the coolant system and low cooling requirements
- **Pressure relief valves**
The pressure relief valves below are especially designed for use in coolant applications.



The **MTA RANGE** – for filtering systems

The MTA range of single-stage immersible pumps has been designed especially for filtering systems in the machine tool industry. The semi-open impellers allow the passing of chips up to 10 mm, making the pumps ideal for removing liquid from any machining process – from boring and milling to grinding. The compact MTA pumps efficiently transport liquid containing chips, fibres and abrasive particles on to the filtering unit.

The low-pressure pumps are available in many different flow variants and come with a choice of bottom suction or suction from the top of the volute. The pump is designed to be maintenance-free, and therefore does not contain shaft seals or other wear parts. MTA pumps can also be used for simple cooling applications.

Materials

Carefully chosen materials ensure trouble-free operation and long life. The top of the pump is made of cast iron, while the impeller is available in composite or bronze. Composite is used in MTA pumps with flow up to 300 l/min. In the bigger pumps with higher flow, the impellers are made of bronze to ensure resistance to for example metal chips. As the pumped liquid will always contain oil, there is no risk of corrosion.

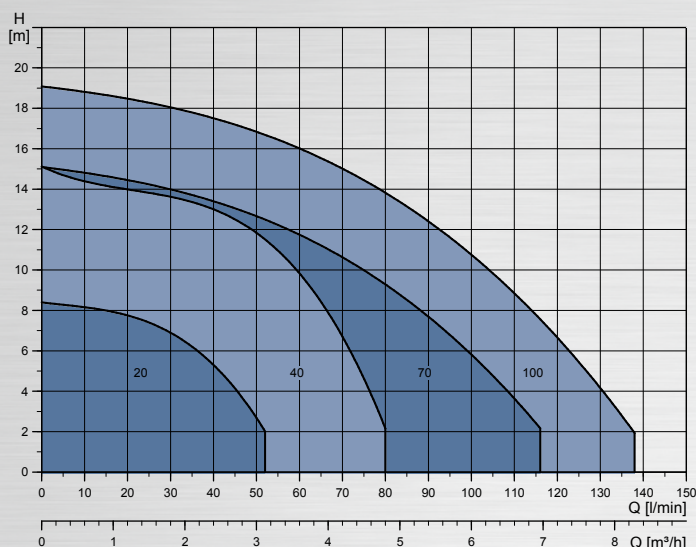

Pump capabilities:

Flow rate:	max 25 m ³ /h (420 l/min)
Head:	max 15 m
Motor:	0.1-0.75 kW
Liquid temp.:	0 °C to +60 °C
Pump sizes:	10

- **Motor**
Three-phase motor, available for global voltages
- **High-efficiency motor and hydraulic**
Low operational costs
- **Variable length**
A number of different immersible lengths are available for each pump size to cover various tank designs
- **Long bearing lifetime**
Maintenance-free
- **No shaft seal**
Prevents leakages
- **Bottom or top suction**
Suction option for different demands
- **Semi-open impeller**
Ensures free passage of solids and chips



The **MTD RANGE** – for filtering systems

Grundfos designed the MTD range of multi-stage immersible pumps especially for filtering systems and lifting stations in the machine tool industry. The medium-pressure pumps are available in flow range from 50 l/min to 300 l/min in different pressure and immersible length variants. Carefully selected materials ensure trouble-free operation and long life, and the MTD is also easy to service and clean.

MTD pumps are compact and efficiently transport liquid containing chips, fibres, and abrasive particles to the filtering unit. Semi-open impellers allow the passing of chips up to 10 mm, making the pumps ideal for removing liquid from any machining process, from boring and milling to grinding.

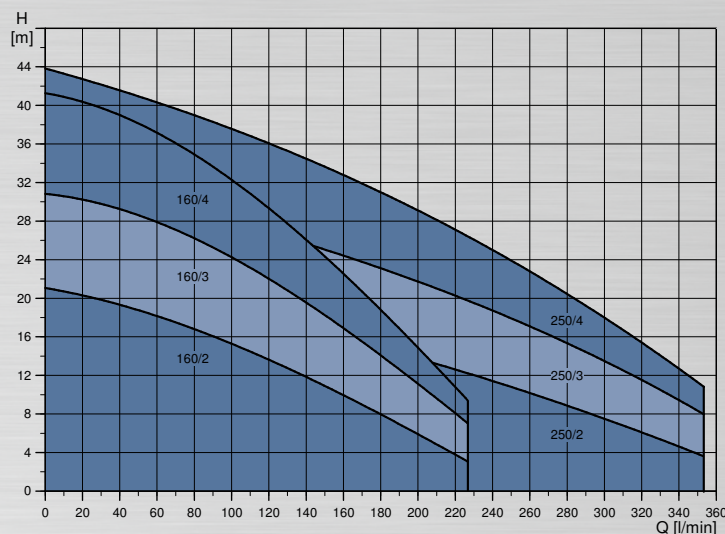

Pump capabilities:

Flow rate:	max 25 m ³ /h (420 l/min)
Head:	max 63 m
Motor:	1.5-4 kW
Liquid temp.:	0 °C to +60 °C
Pump sizes:	2

- **High-efficiency motor**
Standard IE3 motor and with an integrated frequency converter for IE5 motors (MTDE) available for global voltage with three-phase motors
- **Semi-open impeller**
Ensures free passage of solids and chips
- **Leakage-free solution**
Robust mechanical shaft seal keeps hydraulic efficiency high
- **Long lifetime**
Maintenance free
- **High quality materials**
Impeller, chamber and pump house are made of cast iron for durability, and all parts are electro-coated to protect the pump against corrosion
- **Easy installation**
Installation is easy and requires no special tools. The tank-mounting flange dimensions means straightforward replacement of non-Grundfos products

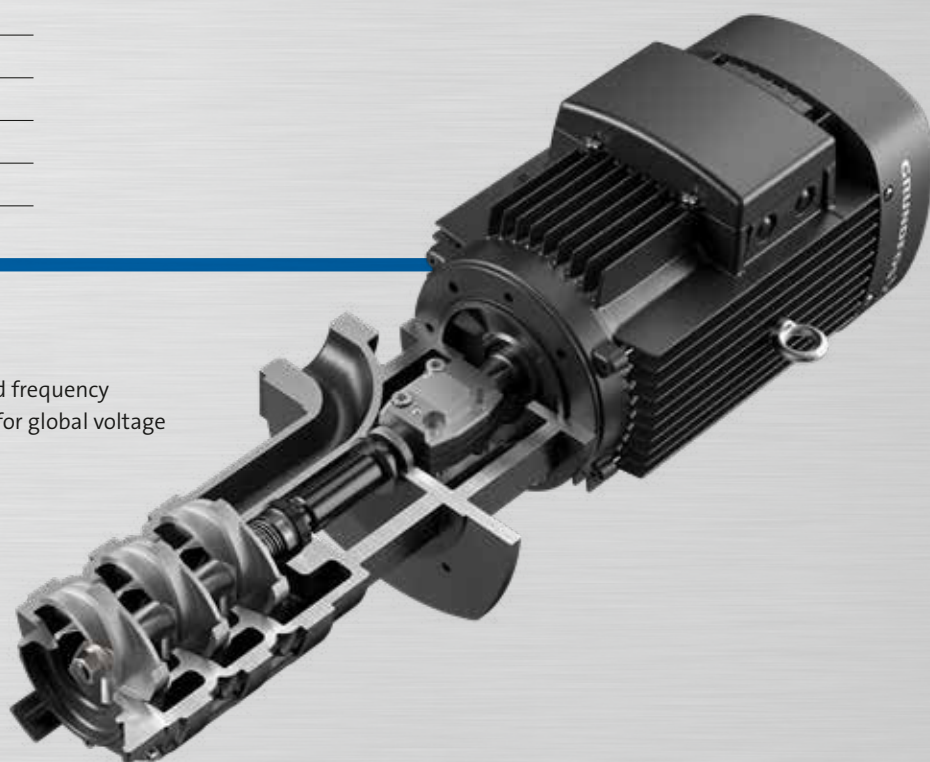

APPROVALS

Meets current motor efficiency requirements applicable in your market such as the global MEPS (Minimum Energy Performance Standards) for the motor

The **MTH RANGE** – with integrated motor

The MTH range of immersible pumps with the motor and pump in one unit is very compact, increasing the ease of installation. Available in cast iron or stainless steel, the MTH range can be supplied in different immersible lengths for varying flow and pressure requirements. The MTH pump comes with dual frequency 50/60 Hz as standard.

The MTH range is ideal for machine tool, wash & clean and chiller applications.

Pump capabilities:

Flow rate: max 25 m³/h (417 l/min)

Head: max 100 m

Motor: 0.55-4 kW

Liquid temp.: -10 °C to +90 °C

Pump sizes: 5

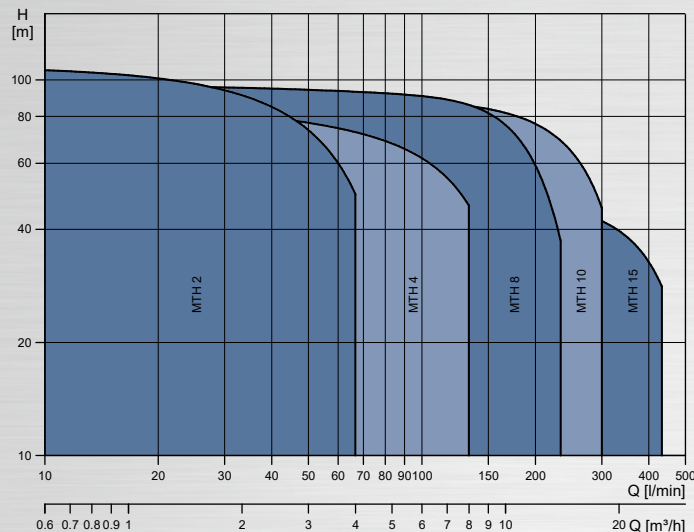

- Motor**
 Standard IE3 motor available for global voltage with single and three-phase motors. Motor protection directly from Klaxon or PTC
- Seal solution**
 Grundfos offers a wide range of mechanical shaft seals with different seal faces such as Silicon Carbide, Carbon and Tungsten Carbide to handle almost any industrial liquid. Drainage back to solution is standard for the MTH range (see page 6)
- Materials**
 Available in cast iron or stainless steel, depending on the application
- Variable length**
 To reach the exact depth of tank, the immersible length can be extended up to 334 mm, depending on pump size
- Inlet**
 Fitted with a suction strainer that prevents large solid particles from entering and damaging the pump. The size of the passage in the strainer and the impeller depends on the pump size. The special priming screw allows for liquid levels down to 25 mm
- Pipe connections**
 Internal thread: Rp, NPT



APPROVALS

Meets current motor and pump efficiency requirements applicable in your market such as the global MEPS (Minimum Energy Performance Standards) for the motor and the Ecodesign requirements for rotodynamic water pumps defined by the Minimum Efficiency Index (MEI)

PARTNERSHIP AND SUPPORT THAT MATCHES THE **QUALITY** OF THE PUMP

Choosing Grundfos as your pump solution partner means you get the benefit of our expertise, cutting-edge technology and customised solutions tailored to your application. Installed on top of the tank, this impressive range of high quality, compact pumps can be customised to your needs.

Grundfos Product Center

The Grundfos Product Center online tool lets you size pumps, browse the Grundfos product catalogue, find appropriate replacement pumps and find pumps for handling specific liquids.

- Search in the way that meets your needs by application, pump design or pump family
- Experience faster sizing thanks to a new intelligent “Quick Size” function
- Documentation includes pump curves, technical specs, CAD drawings, available spare parts, installation videos, and much more
- Optimised for your PC, tablet or smartphone

As a registered user you will have access to saved preferences, products and projects and recent browsing history.

Visit www.product-selection.grundfos.com



Global reach and local support

Grundfos is a truly global company and is never far away. Our unique global set-up provides you with benefits, including:

- Technical assistance to size your pumping system
- Expert know-how and support in your local language
- Web-based tools
- Fast spare parts delivery on every continent

Contact your Grundfos sales representative for further information or help matching a Grundfos immersible pump solution to your industry application.

High **EFFICIENCY** motors

Grundfos MG motors are rated IE3 efficiency as standard with motor protection from Klixon, PTC and PT100. Grundfos MG motors distinguish themselves from standard motors in the market in many ways:

- Optimal lifetime – motor designed to fit pump load
- Wide voltage ranges for both 50 Hz and 60 Hz
- Low noise levels
- Meet or exceed global Minimum Energy Performance Standards (MEPS)
- A range of customised options available on request
- Global availability through Grundfos companies

MGE MOTORS FOR A CONNECTED SOLUTION

The Grundfos MGE motor with integrated frequency converter can operate at different speeds to optimise pump performance for applications ranging from low speed to over-synchronous speed. Immersible pumps with an MGE motor enable you to read data straight from the pump HMI panel or remotely using the Grundfos GO Remote app from your smartphone.

The MGE is a dedicated motor-drive system for pumps. Pumps equipped with MGE motors overcome application challenges and save energy in a variety of pump installations in order to reach the lowest costs possible and ensure a robust solution:

- Built-in protection against mains supply disturbances, environment and motor load
- MGE is designed to mitigate bearing currents
- No cooling fans in drive (wear part)
- Operating temperature between -20 °C and 60 °C allows for installation almost anywhere within high margins in control rooms, resulting in longer product service life

Four application control modes:

- Constant pressure
- Constant differential temperature
- Constant flow
- Constant curve

MANAGE YOUR SYSTEM WITH CIM/CIU COMMUNICATION INTERFACES

The innovative communication Interface Module (CIM) and the Communication Interface Unit (CIU) enable data communication via open and interoperable Networks. The series of Grundfos CIM/CIU communication interfaces offer ease of installation and commissioning, user-friendliness and great value for money in the long term. All modules are based on standard functional profiles for an easy integration into the network and easy understanding of data points.

- Modbus RTU
- Modbus TCP
- BACnet MS/TP
- BACnet IP
- LONWorks
- PROFIBUS DP
- PROFINET IO
- EtherNet/IP
- 3G/4G cellular data connection and SMS
- Grundfos iSOLUTIONS Cloud/Grundfos Remote Management

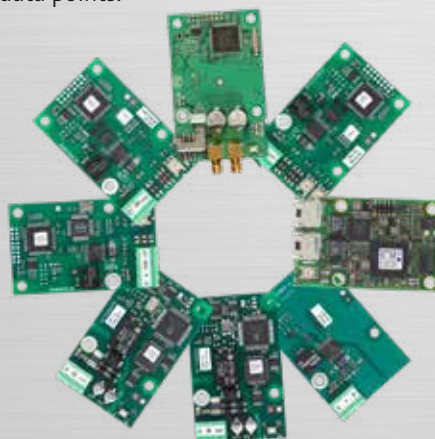

GRUNDFOS GO REMOTE

Grundfos GO Remote for iOS and Android ensures easy and quick commissioning, monitoring and servicing of pumps with MGE motors. Or control from the pump's HMI panel.



PUMP HMI PANEL AVAILABLE IN THREE VARIANTS

Use also the HMI panel to read data directly on the pump:



Basic (HMI100)

- Grundfos EYE
- Wireless communication



Standard (HMI200)

- Grundfos EYE
- Wireless communication
- Start/Stop button for local operation with indicator light
- Setpoint indicator and adjustment



Advanced (HMI300)

- Grundfos EYE
- Wireless communication
- Start/Stop button for local operation
- Full colour display
- Full graphical monitoring and configuration

MOTOR VARIANTS

Grundfos can supply motors that meet special supply voltages, extreme operating conditions, special motor protection, specific approvals and special motor design.

• ATEX approved

A full range of special explosion-proof and dust ignition-proof motors is available with ATEX-approved pumps

• Heating units

Anti-condensation heating can be supplied by a built-in heating unit

• Multi-plug

Our motors are available with a multi-plug (Harting® plug) according to HAN 10 ES for fast mains connections

• Thermal protection

Motors with a built-in bimetallic thermal protector (PTO) or a temperature dependent resistor (PTC) are available. Motors from 3 kW and over have PTC as standard

• Certificates

Certificates for noise, vibration, performance and efficiency levels are available

• Over or undersize motors

For use where the viscosity or density is different from that of water, installations where the altitude exceeds 1000 m or where the ambient temperature is very high

• Terminal box position

The motor can be mounted on the pump head in steps of 90 °C

• Special voltage

A wide range of supply voltages within single and three-phase as well as dual voltage can be supplied.

• Enclosure class

Enclosure class IP 55 is standard on Grundfos motors. Enclosure class IP 65, IP 54 and IP 44 are available as options





GRUNDFOS INDUSTRIAL SOLUTIONS

Grundfos has developed and produced high-quality industrial pumps for more than half a century. Throughout our long history, our focus has always been on product performance and reliability. We strive to provide our customers with the best possible solution, regardless of the application. This dedication to customer needs makes us a preferred pump partner for industries all over the world.

9907373 0919/INDUSTRY/401301-BrandBox

The name Grundfos, the Grundfos logo, and be think innovate are registered trademarks owned by Grundfos Holding A/S or Grundfos A/S, Denmark. All rights reserved worldwide.