

GSD Submersible High Power Slurry Pumps



The GSD Series pump is a heavy-duty slurry pump that delivers high head and high volume discharge. It is designed and built for continuous operation under the rough conditions often found at mega-construction sites and mines.

The GSD Series is a submersible three-phase high power, high head and high volume heavy-duty slurry pump driven by a 4-pole motor. It is equipped with a high-chromium cast iron agitator that assists smooth suction of the settled matters. The pump parts such as the impeller and the suction cover are made of wear-resistant materials. The side discharge, spiral design allows smoother passage of the sucked solid matters. The motor is cooled by a water jacket that assures efficient motor cooling even when it operates with its motor exposed to air. The pump incorporates seal pressure relief ports that prevent the pumping pressure from applying to the shaft seal.

Features

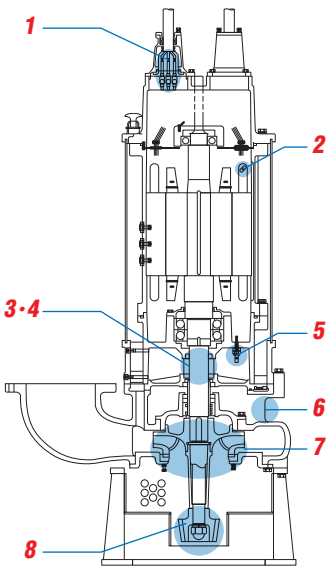

1. Anti-wicking Cable Entry prevents water incursion due to capillary wicking should the power cable be damaged or the end submerged.

2. Miniature Thermal Protectors react to excessive heat caused by dry-running. The bimetal strip opens to cause the control panel to shut the power supply.

3. Dual Inside Mechanical Seal eliminates problems like spring failure and ensures a long service life. Isolated in the oil chamber where a clean, non-corrosive and abrasion-free lubricating environment is maintained.

4. Oil Lifter (Patented) provides lubrication and cooling of the seal faces down to 1/3 of normal oil level, thus maintaining a stable shaft sealing effect and prolonging seal life longer.

5. Leakage Sensor detects flooding into the oil chamber that may occur in a worst case scenario. When flooding is detected, signals are sent to operate the indicator lamps through the external control panel.

6. Seal Pressure Relief Ports protect the mechanical seal from pump pressure. They also protect the seal face by discharging wear particles.

7. Adjustable Impeller Clearance Equipped with a high-chromium cast iron impeller and mouth ring. Even if the performance drops due to wearing out of the impeller and/or mouth ring, it can be improved by adjusting impeller clearance.

8. Agitator Mechanism consists of a shaft-mounted agitator and a dedicated strainer. The agitator made of high-chromium cast iron resists wear caused by abrasive particles, and it suspends solids to assist in pumping sediments in combination with the strainer.

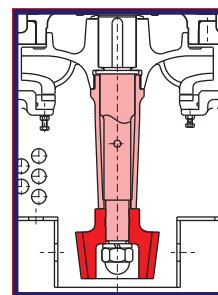
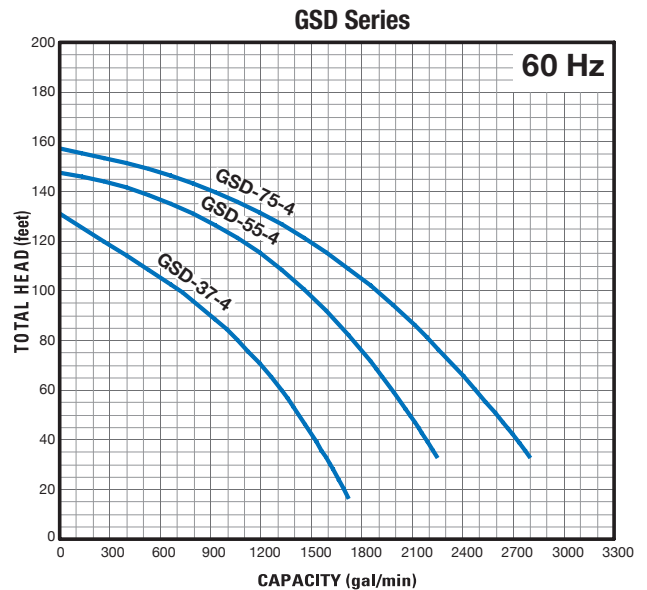

Agitator

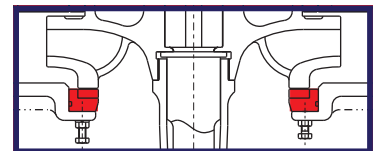

Suction Plate

Specifications

MODEL	MOTOR SPECIFICATIONS				PUMP SPECIFICATIONS					DIMENSIONS		
	Motor Output (HP)	Phase	Rated Current (A)		RPM	Discharge Size (in.)	Maximum Capacity (GPM)	Maximum Head (ft.)	Dimension (in.)		Continuous Running Water Level (in.)	Pump Weight (lbs.)
			460V	575V					Diameter	Height		
GSD-37-4	50	Three	63	49.5	1740	8	1717	131	36	62 5/16	18 7/8	1290
GSD-55-4	75	Three	97	76	1775	10	2245	148	41 5/16	75 7/8	20 1/8	2440
GSD-75-4	100	Three	128	101	1775	10	2800	157	41 5/16	75 7/8	20 1/8	2690

