



PUMP & FILTRATION SYSTEMS ›



Industrial Gear Pumps





Industrial Gear Pumps

Gear pumps transport a wide variety of media in industrial production processes in general, in the chemical industry as well as in the pharmaceutical and food industries. The suitable gear pumps and pump systems can be found in MAAG's wide range of products by plant manufacturers and producers and processors of plastics.

The range of requirements in terms of viscosity, pressure, temperature and corrosivity of the media being conveyed is very wide in the industrial sector.

Our portfolio of industrial gear pumps has exactly the required application depth and, thanks to a sophisticated modular system we can even meet the most difficult requirements reliably.

Thanks to our wide know-how in applications and our very own production, we can optimally design and manufacture the pump tailored to your process.

About us

» The MAAG Group is a broadly diversified global solutions provider with integrated and customizable systems in process technology for the polymer, chemical, petrochemical, pharmaceutical and food industries. Its Pump & Filtration Systems, Pelletizing & Pulverizing Systems, Recycling Systems and Digitalization divisions consolidate the many years of experience and in-depth know-how of the AUTOMATIK, ETTLINGER, GALA, MAAG, REDUCTION, SCHEER and XANTEC product brands. The MAAG Group currently employs over 1,100 people at production sites in Switzerland, Germany, Italy, the USA, and China. Additional sales and service centers in France, Malaysia, India, Thailand and Brazil ensure close attention to customers' needs. «

Applications for highly specific media

Carbon Fibres

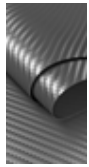

MAAG pumps typically serve as Dope feed/transfer pumps in processing the carbon fibres. Considering the Polyacrylonitrile (PAN) in DMAc Solution, with about 20% of PAN in 80% solvent like DMAc (Dimethylacetamide) or DMSO (Dimethylsulfoxide), also consisting other components and small amounts of water, the mixture has to be pumped through a tiny injector into a chamber where the solvent evaporates and a solid fibre is left out. For this purpose, MAAG pumps are designed to convey and dose the solution with high efficiency.

Spandex



For this application, MAAG pumps are used as spinning or dosing pumps. Spandex or elastane is a synthetic stretchy chemical fibre known for its exceptional elasticity. It exhibits properties similar to rubber, but is more solid and significantly more durable. Possessing viscosity of up to 1,000,000 mPas, the entire process requires a short dwelling time and is carried out under nitrogen (N₂) because the medium reacts to oxygen. MAAG pumps, with their special inlet and seal design, fulfills the necessary requirements of all stages.

Gum Base



Processing of Gum bases (Elastomers, Resins, Waxes, Fats, Emulsifiers, Fillers and Antioxidants) involves several stages such as melting of gum base, mixing with additives and rolling of finished gum. Here, MAAG pumps typically serve, as transfer pumps or as booster pumps in each stage.

Vinyl Alcohol



The production of Ethylene vinyl alcohol copolymer (EVOH) is a two-step process of polymerization and saponification. Ethylene and vinyl acetate are polymerized using an initiator/activator complex. MAAG pumps serve as a transfer pumps for all stages in the process.

Hot Melt - Resin



For Hot melt adhesives used primarily for packaging, textiles, labels, tapes, pressure sensitive applications and other disposable products like stamps, MAAG provides metering/transfer/loading pumps or Booster pumps; for instance, in front of a spray nozzle.

Lubrication and refinery products



MAAG offers customized solutions for simple applications such as grease lubrication, liquid oil, atomized oil (oil mist) or in demanding applications for refinery products like hydrocarbons, unrefined petroleum also in presence of hard particles with special bearings, special sealing designs and materials.

Molten Sulfur



Its production is ever increasing in refineries, natural gas plants, sulphuric acid plants, chemical production such as rubber additives or even in food products. It is also rapidly reaching new industries. Hence, safe handling of molten sulfur and the associated hydrogen sulfide emissions is becoming critical. MAAG pumps usually aid as High Temperature transfer pumps for such precarious applications.

Flavours & Fragrances



Usually a mixture of raw products (fruits, herbs, etc.) and a base solvent (alcohol, acids, etc.). When it comes to manufacturing aromas, it's all about the highly accurate dosing of low-viscosity scent and aroma components. MAAG pumps serve as low viscous distillate removal and corrosive residue removal pumps or serve as dosing pumps to accurately dose flavor additives into perfume.

Food & Pharma



MAAG can offer food-compliant pump executions with stainless steel housings/shafts, ceramic bearings and FDA certified sealings. With their good priming capability, MAAG pumps are well suitable in the pharmaceutical process where the temperatures vary widely, media have low viscosity and accuracy of flow rates is extremely important.



Our promise to you

Technology

MAAG is known worldwide as a pioneer and technology leader in the development and manufacturing of gear pump systems and solutions.

MAAG has always focused on keeping its technology up-to-date and tailor it to meet the needs of individual customers. We promise to go beyond your expectations in this regard.

Innovation

The result of our values and aspiration for customer satisfaction made our industrial pumps come alive. We are confident that the new optimized design, materials used, opens new doors in the application ranges. We promise that this innovation takes the flexibility and maintenance to the next level and ease the efforts put in by the customer in a pump's lifetime.

Quality

Our customer satisfaction has been our top-most priority. Hence, we dedicate a major part of our resources in maintaining and enhancing the quality time-to-time. We promise better standards of quality with our innovations.

Applications at site

MAAG industrial gear pumps are used in various phases in production or media transfer. Gear pumps convey the media from one production phase to the next and therefore are required to work continuously and with reliability. They need to withstand high pressures, high temperatures and highly corrosive materials but at the same time with the highest possible safety for operation.

Unloading from truck to storage silos for various product range

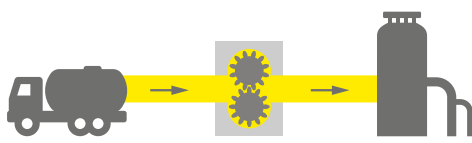

Extraction from the container baths to the purifiers

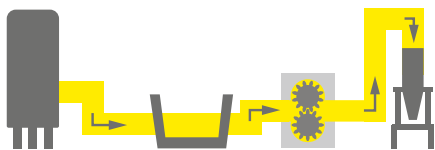

Loading the storage silos from different phases of production

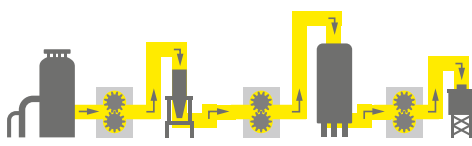

Unloading from the marine tankers to the process areas

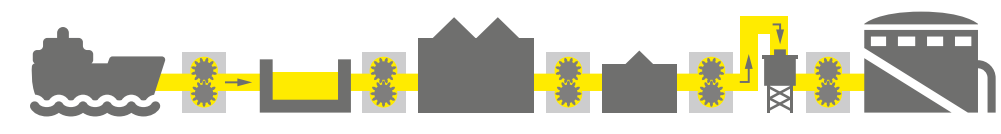





Our pump benefits

- Easy maintenance and replacement of internal parts
- Low NPSHr
- Corrosion resistance
- Extensive portfolio of seals
- In-house manufacturing of all core components
- Low shear
- Reliability and long life
- Precise displacement volume
- Energy efficient
- Dosing accuracy
- Less pulsation during pumping phase
- Wider range of temperature, pressure and viscosity

Our portfolio at a glance

Gear pumps made by MAAG – a sturdy and reliable solution.

Pump	Available with Quick Cleaning Kit™				
	dosix™	flexinox™	cinox/ therminox	cinox V/ therminox V	refinex/ refitherm
High Chemical Resistance					
Example media					
🧪 Chemicals					
Acids	●	●	●		
Solvents	●	●	●		
Additives	●	●	●		
Watery media, cooling media, Detergents	●	●	●		
Paints varnishes	●	●	●		●
Flavours and fragrances	●	●	●		
Molten sulfur	●	●	●		
General	●	●	●		
🔪 Resin					
Polyurethane, Isocyanate		●	●		
Polyurethane, Polyol					●
Adhesives, Hotmelt		●		●	●
Epoxy Resin		●	●	●	●
General		●	●	●	●
🧴 Plastics					
Spandex				●	
Carbon Fibres precursor		●	●		
Prepolymers, oligomers and monomers				●	
Cellulose derivatives and pulps		●	●		
PVA / EVOH		●	●		
General		●	●	●	
🏭 Refinery products & Lubrication					
Petrochemical products					●
Fuels					●
Bitumen, asphalt					●
Waxes and paraffins					●
Lube oil					●
Mineral oils and fats					●
Silicons					●
General					●
🍷 Food & Pharma					
Food	●	●	●		
Pharmaceutical products	●	●	●		
Gum base		●	●	●	
General	●	●	●		

Application/Media:  Chemicals  Resin  Plastics  Food & Pharma  Refinery products & Lubrication

dosix™ and flexinox™



Corrosion-resistant gear pumps and dosing pumps for chemical processes

cinox®-V and therminox®-V



Stainless steel discharge pumps for chemical processes

cinox® and therminox®



Corrosion-resistant gear pumps for chemical processes

refinex® and refitherm®



Cast steel gear pumps for refinery and petrochemical processes

hydrolub®



Grey cast iron gear pumps for industrial processes

hydrolub

Low





dosix™ 14 series

Corrosion-resistant micro pumps
for chemical processes



Dosix 14 micro-pump series is the smallest corrosion-resistant conveying MAAG unit, especially designated for very small and precise throughputs; their three-piece configuration facilitates maintenance and replacement of internal parts, such as gears and bearings. This is a new state of the art development to place MAAG as one of the pioneers in the dosing market. These pumps can be configured with several component combinations to adapt to challenging process parameters and they come in three different sizes: 14/14, 14/8 and 14/4 – optimized for the required flow capacities and other process parameters.

Your benefits

- Wide viscosity, temperature and pressure range
- High volumetric efficiency
- Precise displacement volume
- Low pulsation
- Corrosion-resistance
- Reliability and longevity
- Safety
- Easy replacement of internal parts
- Suitable for step-motors

Optimal for those media:



dosix™ 14 flow rate @ 0 bar ΔP

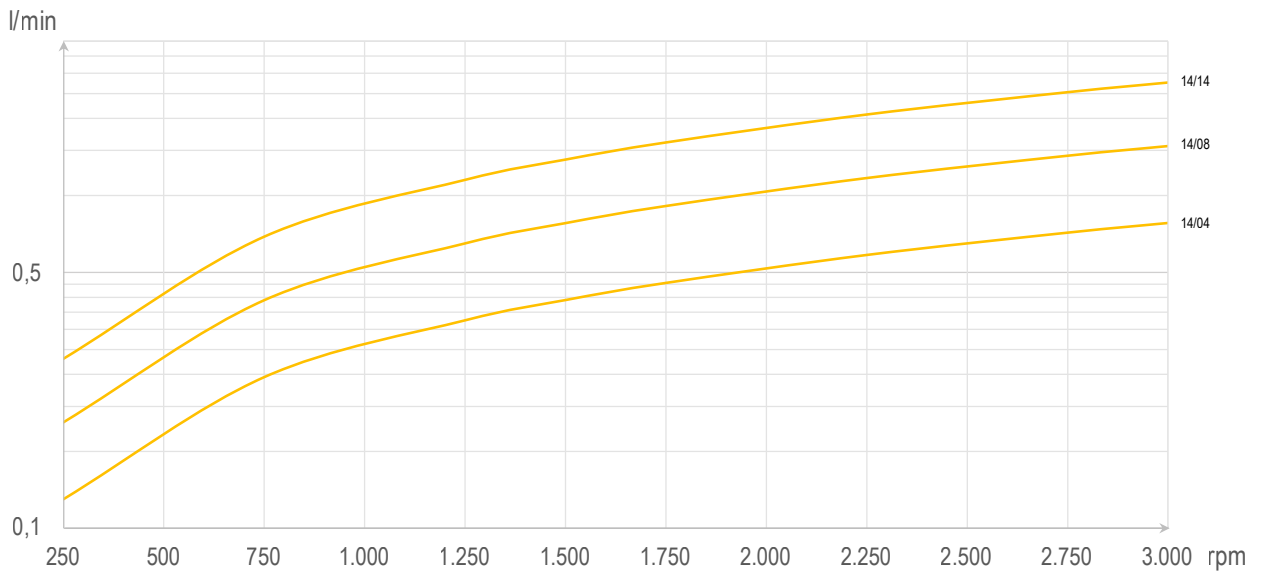



Application limits:

Viscosity:	0.3 to 500,000 mPas
Temperature:	-30 to 100 °C
Suction pressure:	Vacuum up to 50 bar
Discharge pressure:	Vacuum up to 60 bar
Flow rate¹⁾:	From 0.025 to 2,9 l/min

Technical specifications:

Housing:	▪ Stainless steel	
	▪ Hastelloy (upon request)	

Gear shafts:	▪ Stainless steel	
	▪ Ferralium (upon request)	
	▪ Hastelloy (upon request)	

Bearing:	▪ Zirconium Oxide ZrO ₂	
	▪ Synthetic carbon	
	▪ Ceramic SSiC	
	▪ Manganese Bronze	

Shaft seal:	▪ Single mechanical seal	
	▪ Magnetic coupling with single containment shell	

Connections:	▪ Threaded pipe fittings. Others on request.
---------------------	--

A range of typical pumping media

- Organic and inorganic chemicals
- Solvents
- Acids and alkalis
- Additives
- Cosmetic products
- Pharmaceutical products
- Flavours and Fragrances
- Distillation products

Accessories

- Motor flanges and base plates
- Threaded pipe fittings
- Dry-flex coupling
- Electric motors
- Frequency converters
- Step motors

Certificates¹⁾

- ATEX certificate
- 3.1 certificate
- Performance test certificates

Options

- Special modifications for demanding applications
- Customizable

¹⁾ Other certificates and conformities upon request.



dosix™ 20 series

Corrosion-resistant dosing pumps
for chemical processes



MAAG dosing gear pumps are corrosion-resistant and electrically heatable conveying units, especially designated for the small throughputs; their three-piece configuration facilitates maintenance and replacement of internal parts, such as gears and bearings. Thanks to the wide range of components and materials available, dosix™ pumps can be configured to suit customers specific requirements and therefore, are far superior to standard pumps in terms of performance and reliability.

Your benefits

- Wide viscosity, temperature and pressure range
- High efficiencies due to tolerances being modified in line with applications
- Precise displacement volume
- Low pulsation
- Corrosion-resistance
- Reliability and longevity
- Safety
- Easy replacement of internal parts
- Suitable for step-motors

Optimal for those media:



dosix™ 20 flow rate @ 0 bar ΔP

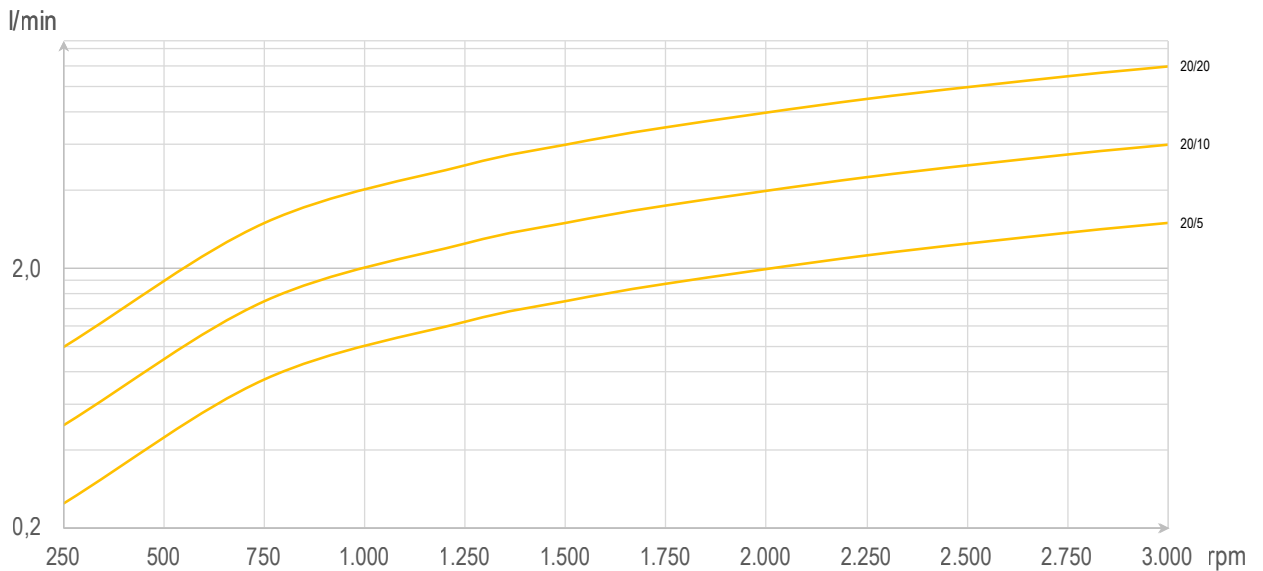

Application limits:

Viscosity:	0.3 to 500,000 mPas
Temperature:	-30 to 320 °C
Suction pressure¹⁾:	Vacuum up to 25 bar
Discharge pressure:	Vacuum up to 100 bar
Flow rate:	From 0.1 to 12 l/min

Technical specifications:

Housing:	▪ Stainless steel
	▪ Hastelloy



Gear shafts:	▪ Stainless steel
	▪ Ferralium
	▪ Hastelloy
	▪ Ceramics
	▪ Technopolymer (upon request)
	▪ Titanium (upon request)



Bearing²⁾:	▪ Zirconium Oxide ZrO ₂
	▪ Synthetic carbon
	▪ Ceramic SiC
	▪ Tegodyn NiAg
	▪ Manganese Bronze



Shaft seal:	▪ Single or double mechanical seal
	▪ Packing seal
	▪ Magnetic coupling with single or double containment shell



Connections:	▪ SAE, CETOP, DIN and ANSI flanges
---------------------	------------------------------------

Heating:	▪ Electrical heating by cartridges on request
-----------------	---

A range of typical pumping media

- Organic and inorganic chemicals
- Solvents
- Acids and alkalis
- Additives
- Cosmetic products
- Pharmaceutical products
- Food extracts and flavourings

Accessories

- Stands, motor flanges and base plates
- Product flange connections
- Couplings
- Motors and gear reducers
- Frequency converters

Certificates³⁾

- ATEX certificate
- 3.1 certificate
- Performance test certificates

Options

- Bi-directional operation
- Special modifications for demanding applications
- Customizable

¹⁾ With special mag drive up to 100 bar.

²⁾ Other materials and designs available.

³⁾ Other certificates and conformities upon request.



flexinox™

Corrosion-resistant gear pumps for chemical processes



MAAG flexinox™ pumps are corrosion-resistant conveying units; they satisfy the stringent quality requirements of today's chemical processing industry and their three-piece configuration facilitates maintenance and replacement of internal parts, such as gears and bearings. They can be heated either electrically or with fluid. Thanks to the extensive range of components and materials available, MAAG gear pumps can be configured to suit customers specific requirements and therefore, are far superior to standard pumps in terms of performance and reliability.

Your benefits

- Wide viscosity, temperature and pressure range
- High efficiencies due to tolerances being modified in line with applications
- Precise displacement volume
- Self-priming
- Corrosion-resistance
- Reliability and longevity
- Safety
- Easy replacement of internal parts

Optimal for those media:



flexinox™ 22-45 flow rate @ 0 bar ΔP

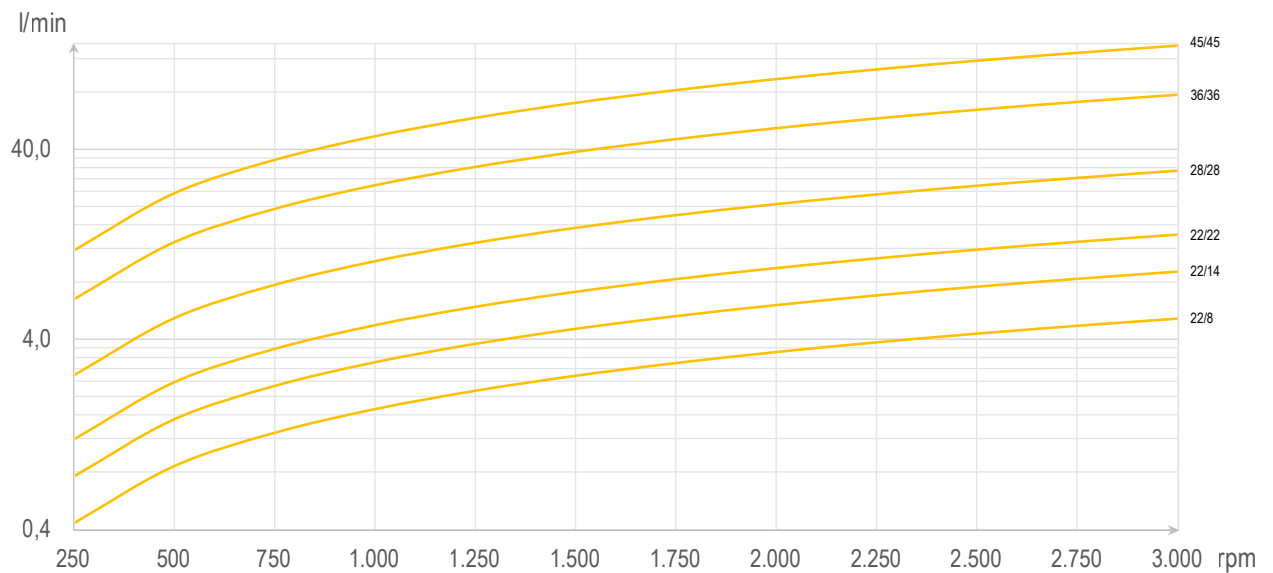

Application limits:

Viscosity:	0.3 to 1,000,000 mPas
Temperature:	-30 to 320 °C
Suction pressure:	Vacuum up to 65 bar
Discharge pressure:	Vacuum up to 150 bar
Flow rate:	From 0.4 to 139 l/min

Technical specifications:

Housing:	■ Stainless steel
	■ Hastelloy



Gear shafts:	■ Stainless steel
	■ Ferralium
	■ Hastelloy
	■ Ceramics
	■ Technopolymer (upon request)
	■ Titanium (upon request)



Bearing¹⁾:	■ Synthetic carbon
	■ Stainless steel with carbon inserts
	■ Ceramic SiC, ZrO ₂
	■ Tegodyn NiAg
	■ Bronze CuAl
	■ Hardened tool steel



Shaft seal:	■ Single or double mechanical seal
	■ Single or double mechanical balanced seal
	■ Packing seal
	■ Sealing ring in a wide range of materials
	■ Sealing medium or heating medium connections available
	■ Magnetic coupling with single or double containment shell



Connections:	■ SAE, CETOP, DIN and ANSI flanges
---------------------	------------------------------------

Heating:	■ Electrical heating by cartridges on request
	■ Integrated channels for heating/cooling by steam or liquid

A range of typical pumping media

- Organic and inorganic chemicals
- Solvents
- Acids and alkalis
- Emulsions
- Sludges and condensates
- Prepolymers, oligomers, and monomers (PAN)
- Additives
- Resins
- Cellulose derivatives and pulps
- Silicones
- Waxes and paraffins
- Cosmetic products
- Pharmaceutical products
- Food extracts and flavourings
- Gum base
- Vegetable/animal oils and fats
- Molten Sulfur

Accessories

- Stands, motor flanges and base plates
- Product flange connections
- Couplings
- Motors and gear reducers
- Frequency converters
- Shaft seal systems (with buffer tanks)

Certificates²⁾

- ATEX certificate
- 3.1 certificate
- Performance test certificates

Options

- Bi-directional operation
- Special modifications for demanding applications
- Customizable

¹⁾ Other materials and designs available.

²⁾ Other certificates and conformities upon request.



cinox® therminox®

Corrosion-resistant gear pumps
for chemical processes



cinox® and therminox® gear pumps are corrosion resistant and heatable stainless steel conveying units that satisfy the stringent quality requirements of today's chemical processing industry. Whether the applications involve highly pure, corrosive, viscous or very hot media, MAAG pump systems hold the solution to meet every pumping challenge. cinox® and therminox® are especially suitable for medium-high flow rates.

Your benefits

- Wide viscosity, temperature and pressure range
- High efficiencies due to tolerances being modified in line with applications
- Precise displacement volume
- Self-priming
- Corrosion-resistance
- Reliability and longevity
- Safety

Optimal for those media:



cinox® therminox® 22-180 flow rate @ 0 bar ΔP

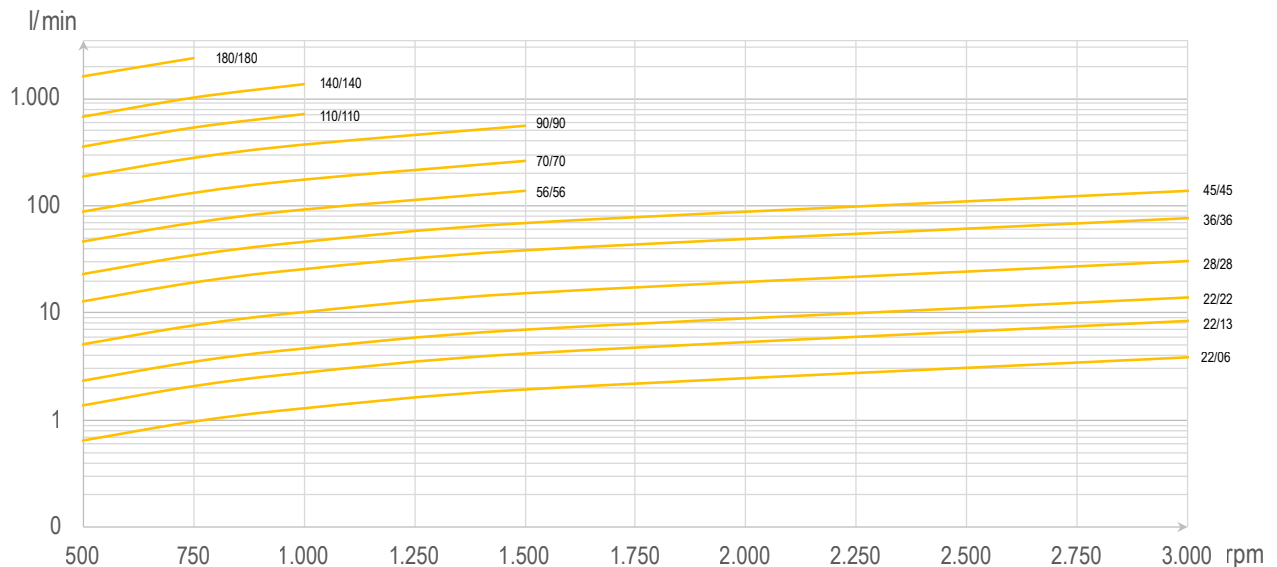

Application limits:

Viscosity:	0.3 to 4,000,000 mPas
Temperature:	-30 to 320 °C
Suction pressure:	Vacuum up to 65 bar
Discharge pressure:	Vacuum up to 200 bar
Flow rate¹⁾:	0.1 to 2,400 l/min

Technical specifications:

Housing:	■ Stainless steel
	■ Hastelloy



Gear shafts:	■ Stainless steel
	■ Ferralium
	■ Hastelloy
	■ Ceramic SSiC
	■ Technopolymer (upon request)



Bearing²⁾:	■ Synthetic carbon
	■ Stainless steel with carbon inserts
	■ Ceramic SSiC, ZrO ₂
	■ Tegodyn NiAg
	■ Bronze CuAl
	■ Hardened tool steel



Shaft seal:	■ Single or double mechanical seal
	■ Single or double mechanical balanced seal
	■ Packing seal
	■ Sealing ring in a wide range of materials
	■ Sealing medium or heating medium connections available
	■ Magnetic coupling with single or double containment shell



Connections:	■ SAE, CETOP, DIN and ANSI flanges
---------------------	------------------------------------

Heating:	■ Electrical heating by cartridges optional for cinox®
	■ Integrated channels for heating/cooling by steam or liquids for therminox®

A range of typical pumping media

- Organic and inorganic chemicals
- Solvents
- Acids and alkalis
- Emulsions
- Sludges and condensates
- Prepolymers, oligomers, and monomers (PAN)
- Additives
- Resins
- Cellulose derivatives and pulps
- Silicones
- Waxes and paraffins
- Cosmetic products
- Pharmaceutical products
- Food extracts and flavourings
- Gum base
- Vegetable/animal oils and fats
- Molten Sulfur

Accessories

- Stands, motor flanges and base plates
- Product flange connections
- Couplings
- Motors and gear reducers
- Frequency converters
- Shaft seal systems (with buffer tanks)

Certificates³⁾

- ATEX certificate
- 3.1 certificate
- German Air Quality certificate (TA-Luft)
- Performance test certificates

Options

- Heated seals
- Bi-directional operation
- Special modifications for demanding applications

¹⁾ Higher flow rates upon request.

²⁾ Other materials and designs available.

³⁾ Other certificates and conformities upon request.



cinox[®]-V therminox[®]-V

Stainless steel discharge pumps for chemical processes



The pump models cinox[®]-V therminox[®]-V are discharge pumps. They have been designed for highly viscous fluids, which are gently extracted from reactors and degassing devices even when the inlet pressure is low, ensuring optimum filling characteristics and short dwell times. This new pump series combines the outstanding flow characteristics of the polymer pumps with the exacting requirements of the chemical industry.

Your benefits

- Optimum fill characteristics due to enlarged inlet and optimum inlet geometry
- Low pulsation
- High efficiencies thanks to application-specific clearances
- Reliability
- Longevity
- Safety

Optimal for those media:



cinox®-V therminox®-V 28-70 flow rate @ 0 bar ΔP

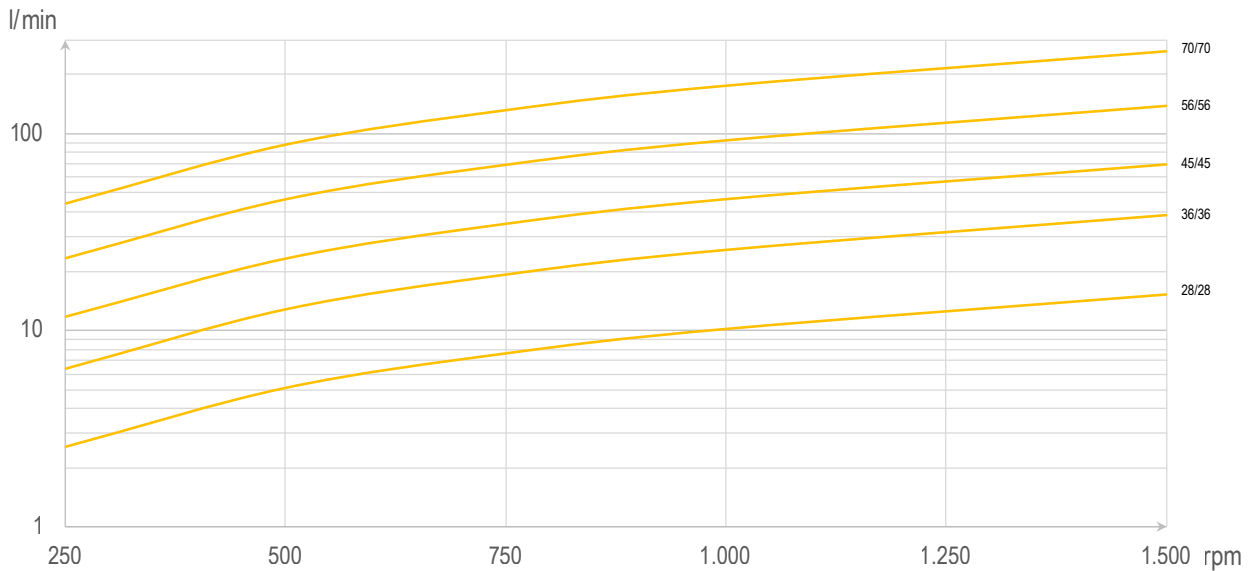

Application limits:

Viscosity:	0.3 to 4,000,000 mPas
Temperature:	-30 to 320 °C
Suction pressure:	Vacuum up to 16 bar
Discharge pressure:	Vacuum up to 200 bar
Flow rate¹⁾:	2.5 to 265 l/min

Technical specifications:

Housing: ■ Stainless steel



Gear shafts²⁾: ■ Stainless steel



Bearing²⁾: ■ Hardened tool steel



Shaft seal:

- Double mechanical seal
- Interlock or heater connections available
- Seal ring from a range of materials
- Packing gland throttled (optional spring loaded)



Connections: ■ Flanges (other optional) ANSI, DIN

Enlarged inlet: ■ Enlarged inlet geometry for low NPSH at high viscosities

A range of typical pumping media

- Prepolymers, oligomers, and monomers
- Dopes
- Spandex
- Resins
- Adhesives
- Silicones
- Waxes and paraffins
- Emulsifying agents
- Gum base

Accessories

- Product connecting flanges
- Motors and gear reducers
- Universal cardan shafts, hubs
- Frequency converters
- Sealing liquid system

Certificates³⁾

- ATEX certificate
- 3.1 certificate
- German Air Quality certificate (TA-Luft)
- Performance test certificates

Options

- Electrical heating
- Heated product flanges

¹⁾ Higher flow rates upon request.

²⁾ Other materials and designs available.

³⁾ Other certificates and conformities upon request.



refinex[®] refitherm[®]

Cast steel gear pumps for refineries
and petrochemical processes



Refinery and industrial plant applications are challenging. High process pressures and high temperatures are commonplace in such environments. Precisely in these environments MAAG gear pumps develop their full potential. Thanks to the extensive range of components and materials of constructions to choose from, MAAG gear pumps can be configured to suit customers specific requirements and therefore, are far superior to standard pumps in terms of performance and reliability.

Your benefits

- Wide viscosity, temperature, and pressure range
- High efficiencies (due to tolerances and small clearances being modified in line with applications)
- Precise displacement volume
- Self-priming
- Reliability and longevity
- Suitable for API 676

Optimal for those media:



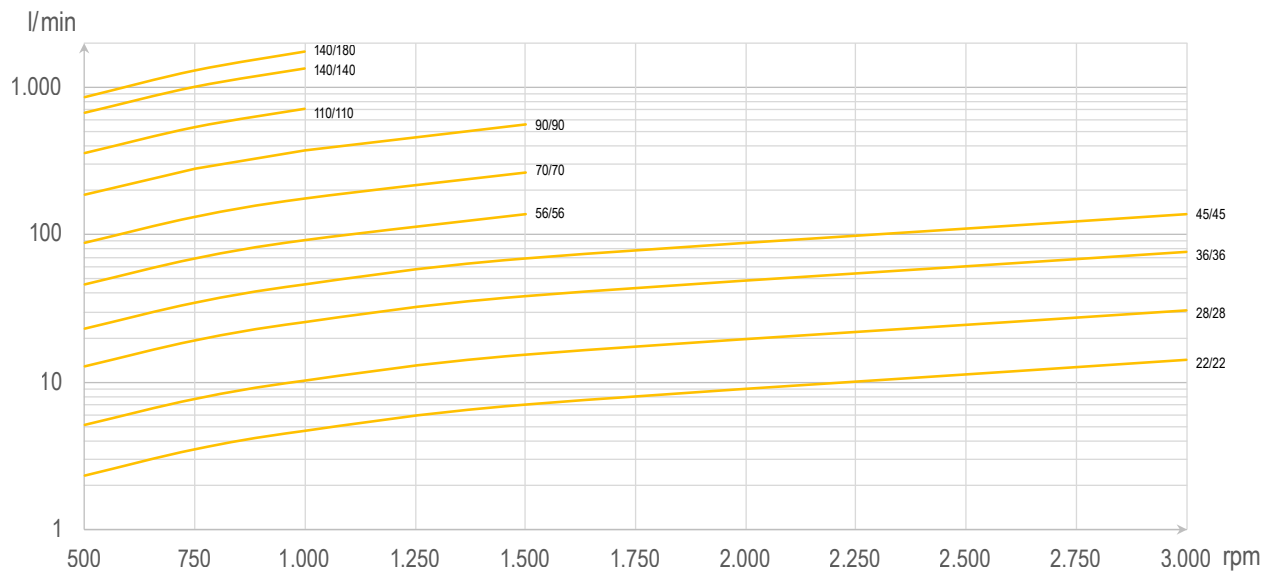

Application limits:

Viscosity:	0.3 to 4,000,000 mPas
Temperature:	-30 to 320 °C
Suction pressure:	Vacuum to 65 bar
Discharge pressure:	Vacuum to 300 bar
Flow rate¹⁾:	0.5 to 1,750 l/min

Technical specifications:

Housing: ■ Cast steel



Gear shafts: ■ Stainless steel
 ■ Nitrided steel (spur and helical)
 ■ Nitrided steel coated



Bearing²⁾: ■ Manganese bronze
 ■ Sintered iron
 ■ Synthetic carbon
 ■ Steel with carbon inserts
 ■ Nitrided steel
 ■ Nitrided steel coated
 ■ Hardened tool steel
 ■ Bronze – CuAl



Shaft seal: ■ Lip seals and packing
 ■ Single or double mechanical seal
 ■ External mechanical seal
 ■ Sealing medium or heating medium connections available
 ■ Magnetic coupling with single or double containment shell



Connections: ■ SAE, CETOP, DIN, and ANSI flanges

Heating: ■ Electrical heating by cartridges optional for refinex®
 ■ Integrated channels for heating / cooling by means of steam or liquids for refitherm®

A range of typical pumping media

- Emulsions
- Sludges and condensates
- Additives
- Resins
- Cellulose derivatives and pulps
- Silicones
- Adhesives and hot-melt adhesives
- Paints and varnishes
- Waxes and paraffins
- Fertilizers
- Mineral oils and fats
- Fuels
- Petrochemical products

Certificates³⁾

- ATEX certificate
- 3.1 certificate
- German Air Quality certificate (TA-Luft)
- Performance test certificates

Options

- Electrical heating
- Heated seals
- Bi-directional operation
- Special modifications for demanding applications

¹⁾ Higher flow rates upon request.

²⁾ Other materials and designs available.

³⁾ Other certificates and conformities upon request.



hydrolub®

Grey cast iron gear pumps
for industrial processes



Continuously operated equipment calls for reliable components. Whether in lubrication oil applications or in processing plants, a pump is required to work reliably and long-lasting. Thanks to the extensive range of components and pump sizes, hydrolub® can be configured to suit customers' specific requirements and therefore, are far superior to standard pumps in terms of performance.

Your benefits

- High efficiencies (due to tolerances and small clearances being modified in line with applications)
- Precise displacement volume
- Self-priming
- Reliability and longevity
- Safety
- Low pulsations for oil applications (helical gears)

Optimal for those media:



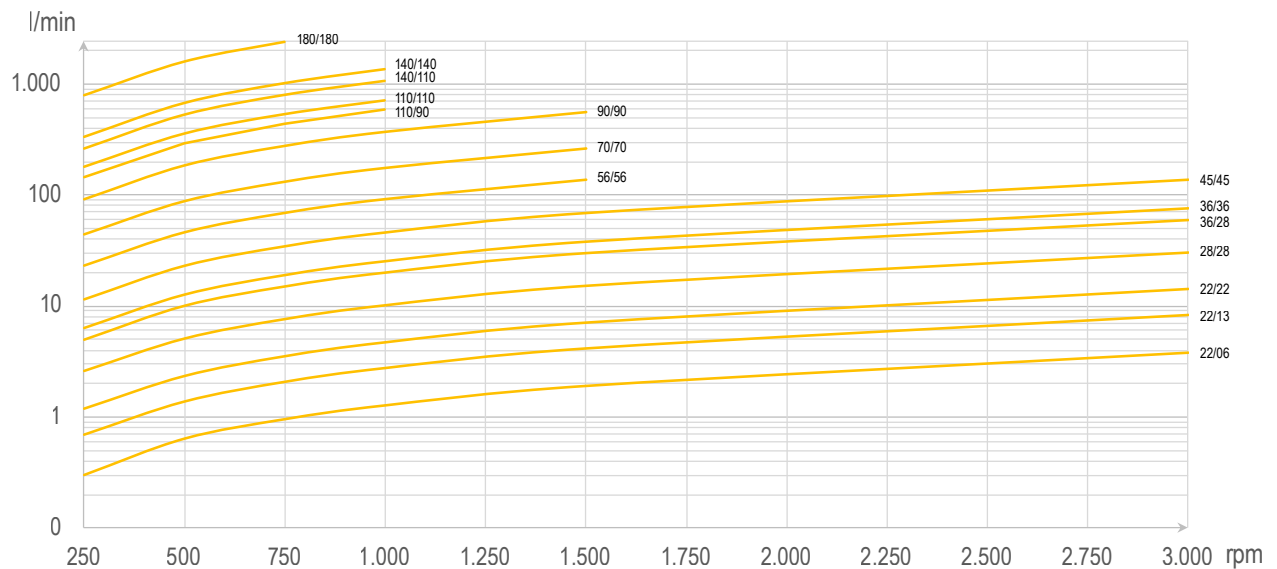

Application limits:

Viscosity:	0.3 to 4,000,000 mPas
Temperature:	-30 to 150 °C
Suction pressure:	Vacuum to 65 bar
Discharge pressure:	Vacuum to 120 bar
Flow rate:	0.1 to 2,400 l/min

A range of typical pumping media

- Silicones
- Paints and varnishes
- Waxes and paraffins
- Mineral oils and fats
- Fuels
- Petrochemical products
- Lube oil

Technical specifications:

Housing: ■ Pressure-resistant cast iron



Gear shafts: ■ Nitrided steel (spur, helical or coated)



Bearing²⁾:

- Manganese bronze
- Sintered iron
- Synthetic carbon
- Steel with carbon inserts
- Nitrided steel
- Nitrided steel coated
- Hardened tool steel
- Bronze – CuAl



Shaft seal:

- Lip seals and packing
- Single or double mechanical seal
- External mechanical seal
- Sealing medium or heating medium connections available
- Magnetic coupling with single or double containment shell



Connections: ■ SAE, CETOP, DIN, and ANSI flanges

Accessories

- Stands, motor flanges and base plates
- Product connecting flanges
- Couplings
- Motors and gear reducers
- Frequency converters
- Shaft seal systems

Certificates³⁾

- ATEX certificates
- 3.1 certificate
- German Air Quality certificate (TA-Luft)
- Performance test certificates

Options

- Heated seals
- Bi-directional rotation
- Special modifications for demanding applications
- Integrated safety valve on request

¹⁾ Other pump sizes and higher flow rates available.

²⁾ Other materials and designs available.

³⁾ Other certificates and conformities upon request.

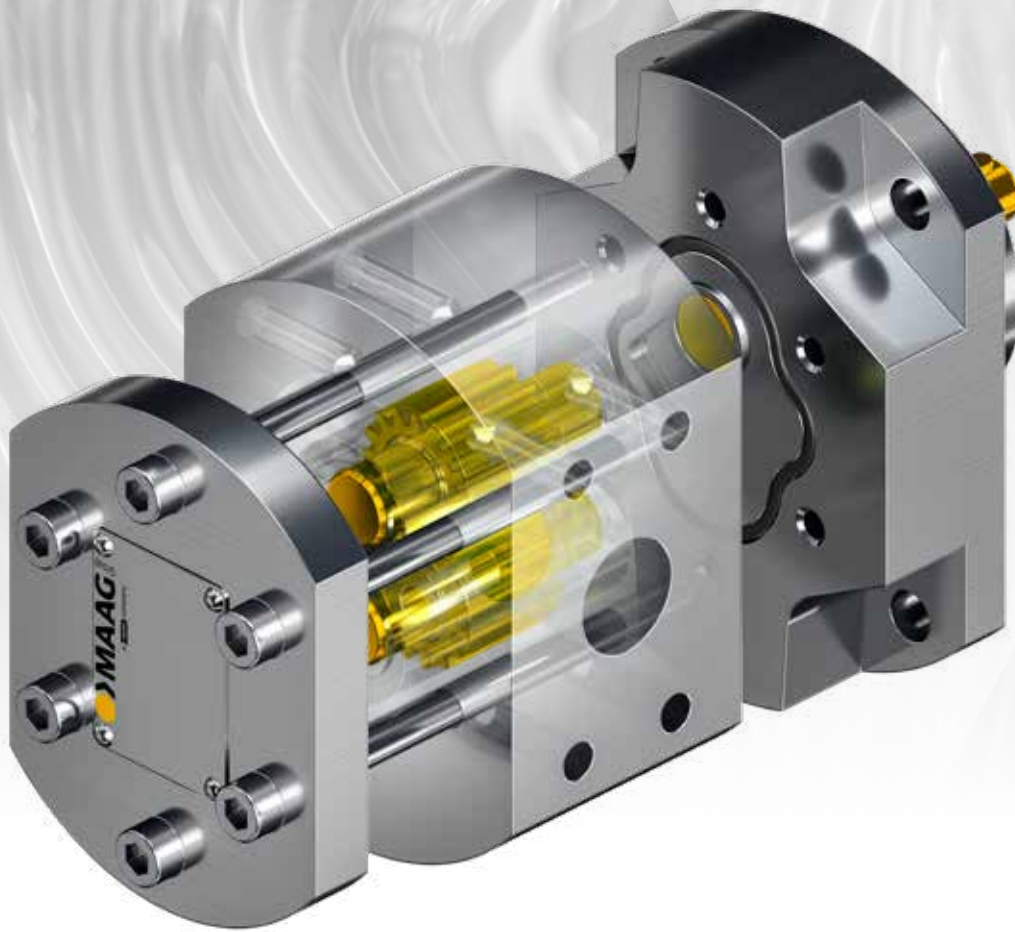

Quick Cleaning™ Kit

Kit for easier, quicker cleaning
of pump components



As the name suggests, this revolutionary pump version comes with a possibility for quick, easy, complete cleaning of the pump internals without disassembling the flange from the drive system. The Quick Cleaning can improve the production and maintenance style without affecting the overall performance. This feature can be selected as a whole or applied to the existing pump series FX and DX.

Your benefits

- Easy and fast replacement of internal parts
- Reliability and longevity
- Safety
- Easy pump disassembly on the plant

Optimal for those media:



Quick Cleaning™ Kit 14-20 flow rate @ 0 bar ΔP

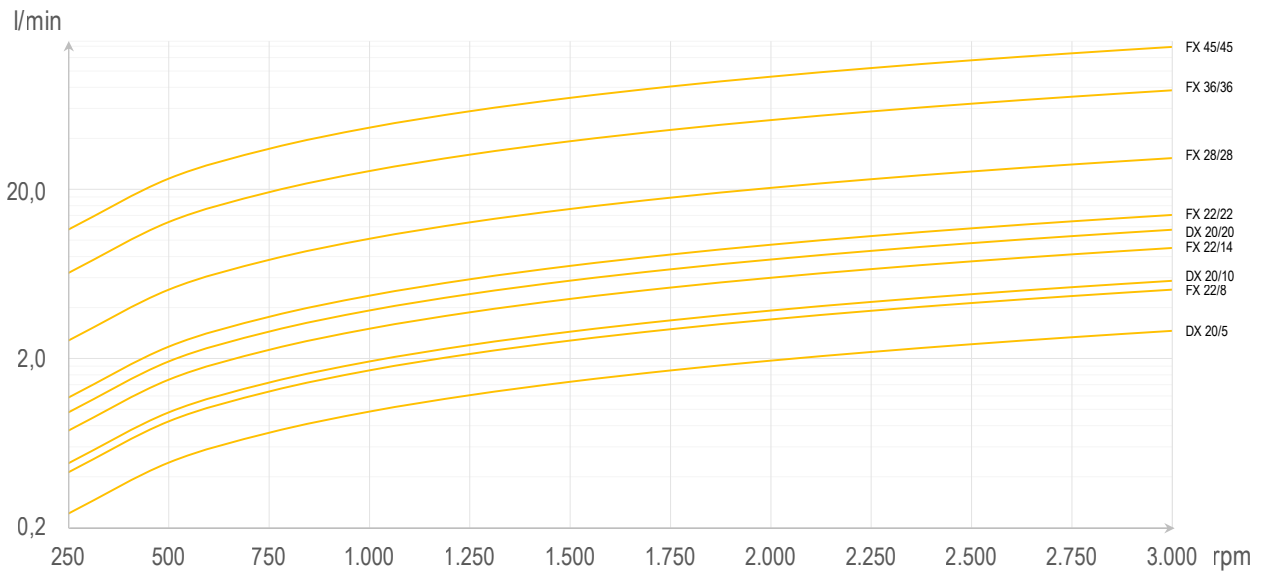

Application limits:

Viscosity:	0.3 to 1,000 mPas
Temperature:	-30 to 100 °C
Suction pressure:	Vacuum up to 15 bar
Discharge pressure:	Vacuum up to 45 bar
Flow rate:	From 0.1 to 139 l/min

Suitable for:

- Pump type:**
- Dosix series 20
 - Flexinox standard series



- Gear shafts:**
- Stainless steel
 - Ferralium
 - Hastelloy



- Bearing¹⁾:**
- Zirconium Oxide ZrO₂
 - Synthetic carbon
 - Ceramic SSiC
 - Tegodyn NiAg
 - Manganese Bronze



- Shaft seal:**
- Single mechanical seal for QC kit



- Connections:**
- SAE, CETOP, DIN and ANSI flanges

A range of typical pumping media

- Organic and inorganic chemicals
- Additives
- Cosmetic products
- Pharmaceutical products
- Food extracts and flavourings

Accessories

- All the accessories for DX and FX
- Couplings
- Motors and gear reducers
- Frequency converters

Certificates²⁾

- 3.1 certificate
- Performance test certificates

¹⁾ Other materials and designs available.

²⁾ Other certificates and conformities upon request.

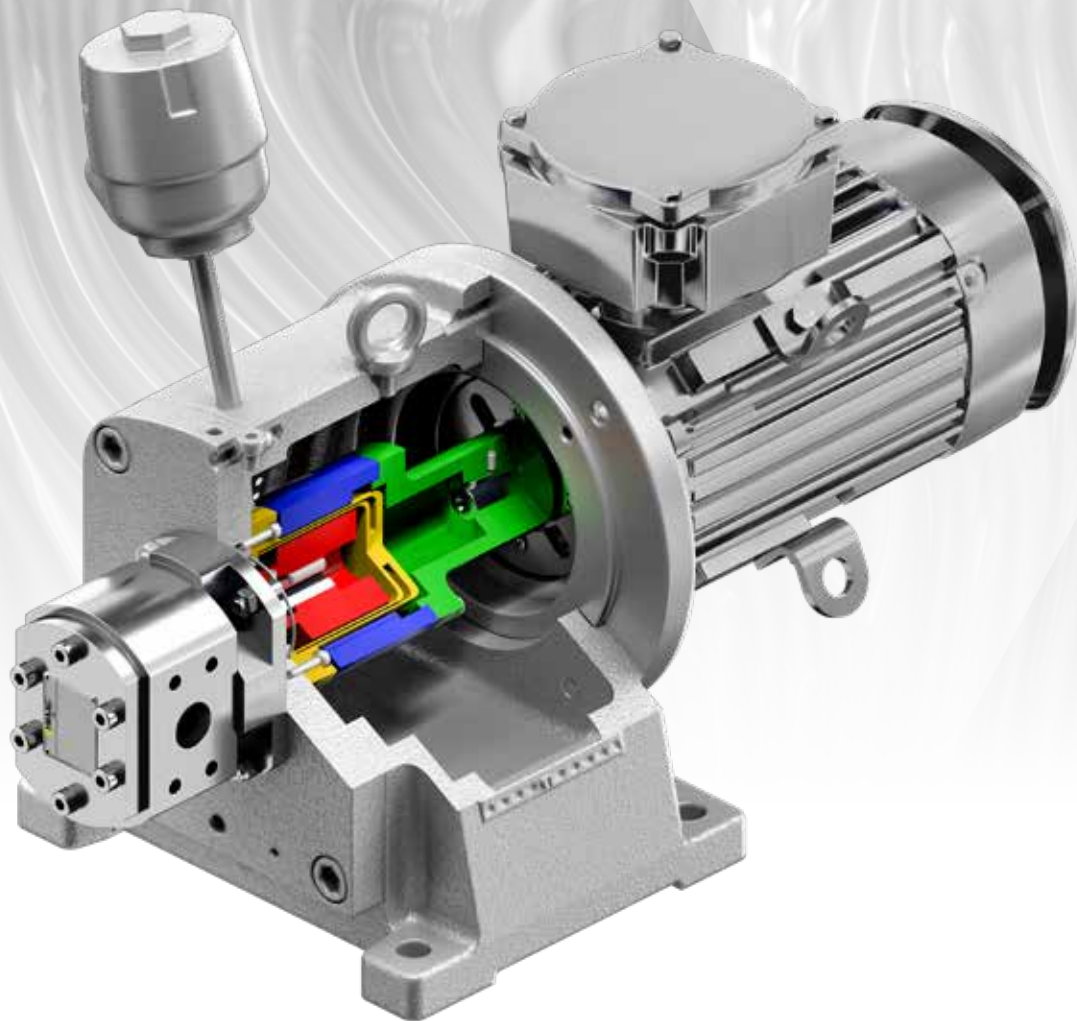

mag drive

Magnetic coupling for chemical and industrial processes



Magnetic drives are hermetically sealed thereby guaranteeing that environmentally hazardous, poisonous, and malodorous substances are pumped safely. The product chamber in the gear pump is completely separated from the environment by a containment shell. The torque is transferred from motor shaft to pump shaft without contact by means of heavy-duty permanent magnets. This design makes the magnetic couplings extremely safe and virtually maintenance-free.

Your benefits

- High suction pressures (standard to 25 bar, in special designs up to 100 bar)
- Hermetically-sealed design
- Optimized safety and leak sealing
- Long service life
- Virtually maintenance-free
- Low maintenance costs

Optimal for those media:



Application limits:

Viscosity:	1 to 5,000 mPas
Temperature:	-30 to 300 °C
Suction pressure:	<ul style="list-style-type: none"> ■ Vacuum to 25 bar ■ Special designs up to 100 bar available
Discharge pressure:	Vacuum to 100 bar

Typical pumping media and their characteristics

- Toxic: hydrochloric acids, benzene, coolants, phenol, molten sulfur
- Malodorous: nitric acid, acids, anhydrides, fats, thermal oils, flavorings
- Volatile: solvents, condensates
- Combustible: solvents, nitrate, explosive substances, blasting oils, nitroglycerin
- Highly pure: pharmaceutical products
- Crystallize on contact with air: isocyanates

Certificates¹⁾

- ATEX certificate
- 3.1 certificate
- Performance test certificates
- German Air certificate (TA-Luft)

Options

- Special designs for suction pressures up to 100 bar
- Temperature monitoring on containment shell
- Temperature, pressure or level monitoring of sealing liquid

Technical data:

Magnetic drive Type SMC (with a single containment shell):	SMC 45-04	SMC 45-8	SMC 60-07	SMC 60-14	SMC 60-22	SMC 75-30	SMC 110-50	SMC 110-80	SMC 135-135
Transferable torque in Nm:	4	8	7	14	22	30	50	80	135
Magnetic drive Type SMCD (with a dual containment shell):	-	-	SMCD 60-07	SMCD 60-14	SMCD 60-22	SMCD 75-30	SMCD 75-40	SMCD 110-50	SMCD 135-180
Transferable torque in Nm:	-	-	7	14	22	30	40	110	180

Pump size	Theoretical pumping capacities in l/min at 0 bar dp				Motor flange ø [mm]	Magnetic drive sizes ²⁾
	500	750	1,000	1,500		
14/04	0,13	0,19	0,26	0,39	160	SMC 45-04
14/08	0,26	0,39	0,52	0,78	160	SMC 45-04
14/14	0,46	0,68	0,91	1,36	160	SMC 45-04
20/05	0,48	0,72	0,96	1,44	200	SMC 60-07, SMCD 60-07
22/06	0,64	0,96	1,28	1,92	200	SMC 60-07, SMCD 60-07
22/08	0,85	1,27	1,7	2,55	200	SMC 60-07, SMCD 60-07
20/10	0,96	1,44	1,92	2,88	200	SMC 60-07, SMCD 60-07
22/13	1,39	2,09	2,78	4,17	200 250	SMC 60-07, SMCD 60-07 SMC 60-14, SMCD 60-14
22/14	1,5	2,25	3	4,5	200 250	SMC 60-07, SMCD 60-07 SMC 60-14, SMCD 60-14
20/20	1,92	2,88	3,84	5,76	200	SMC 60-07, SMCD 60-07
22/22	2,35	3,53	4,7	7,05	200 250	SMC 60-07, SMCD 60-07 SMC 60-14, SMCD 60-14
28/28	5,1	7,65	10,2	15,3	250	SMC 60-14, SMC 60-22, SMCD 60-14, SMCD 60-22
36/36	12,8	19,2	25,6	38,4	250 300	SMC 60-22, SMCD 60-22 SMC 75-30, SMC 110-50, SMCD 75-30, SMCD 110-50
45/45	23,2	34,7	46,3	69,5	300 350	SMC 75-30, SMC 110-50, SMCD 75-30, SMCD 110-50 SMC 110-80, SMC 135-135
56/56	46,3	69,5	92,6	138,9	300 350	SMC 75-30, SMC 110-50, SMCD 75-30, SMCD 110-50 SMC 110-80
70/70	88	132	176	264	350	SMC 110-80, SMCD 110-50, SMCD 135-180

¹⁾ Other certificates and conformities upon request.

²⁾ Other sizes upon request.

Service around the clock. Worldwide.

Face-to-face. Digital.

For MAAG Group, "service" is far more than just supplying spare parts. Contacting and supporting a wide range of customers, from small and specialized ones to large multinational manufacturers, has provided us with expert service knowledge found nowhere else in the industry.

Our experts within our fields of competence support our customers remote or face to face by presenting solutions that fit their unique requirements. We start with the important step of a comprehensive process analysis. Only if all individual components of a system are ideally matched and coordinated, minimized waste, reduced downtimes, improved product quality, optimized production and reduced energy costs can be achieved. Thanks to networked machines, we can use real-time data to perform predictive maintenance on the customer's plant and optimize its operation and service life. Even remote start-ups are already possible today.

With a very large number of machines and systems installed at over 25,000 customers worldwide, MAAG Group has over the past decades built up a high level of expertise in pump technology, filtration, pelletizing, pulverizing, and recycling that is unique in the world. With a high level of expertise in control system technology and data processing, the digitalization experts of the MAAG Group develop investment projects with their customers - from the first rough idea to the handover of the operational plant. Specialized consulting and process support is an essential part of MAAG Group's current range of products and services and its extensive global network of services.

MAAG Group maintains service centers in Germany, Switzerland, Italy, Malaysia, the USA, Brazil, China, Thailand, and India. With these worldwide locations and their associated proximity to customers, we have earned a reputation for providing prompt, reliable service to our customers – before, during, and after the purchase. In addition, an extensive inventory of wear and spare parts is always available for immediate shipment. Since all spare parts are manufactured to original specifications, our customers can always rely on their design, quality, and reliability to keep their systems running at peak performance.



MAAG Group
A ZF company

Learn more about the wide range of services offered by MAAG Group and our strong product brands AUTOMATIK, ETLINGER, GALA, MAAG, REDUCTION, SCHEER and XANTEC. We look forward to collaborate with you!

www.maag.com
welcome@maag.com
T + 41 44 27882-00



Your experts for Industrial Gear Pumps
Maag Italy s.r.l.
+39 02 5759321
MaagItaly@maag.com

-  Manufacturing
-  Sales
-  Service
-  Sharpening center
-  Test and development

Europe

Headquarters in Switzerland

Maag Pump Systems AG
 Oberglatt
 +41 44 27882-00
 welcome@maag.com



Germany

Maag Germany GmbH
 Grossostheim
 +49 6026 503-0
 info@maag.com



Maag Germany GmbH
 Xanten
 +49 2801 980-0
 maag.xan.info@maag.com



XanTec Steuerungs- und
 Edv Technik GmbH
 Kevelaer-Kervenheim
 +49 2825 93 94-0
 info@maag.com



Ettlinger
 Kunststoffmaschinen GmbH
 Königsbrunn
 +49 8231 34908-00
 info.ettlinger@maag.com



France

Maag Pump Systems SAS
 Villeurbanne
 +33 4 7268673-0
 MaagFrance@maag.com



Italy

Maag Italy s.r.l.
 Rozzano (MI)
 +39 02 5759321
 MaagItaly@maag.com



Americas

Brazil

Maag Automatik
 c/o Dover do Brasil
 Jundiai – SP
 +55 11 292366-00
 InfoBrazil@maag.com



USA

Ettlinger North America
 Atlanta, GA
 +1 770 703 8541
 info.ettlinger@maag.com



Maag Reduction, Inc.
 Charlotte, NC
 +1 704 716 9000
 MaagAmericas@maag.com



Maag Gala, Inc.
 Eagle Rock, VA
 +1 540 884 2589
 MaagAmericas@maag.com



Maag Reduction, Inc.
 Kent, Ohio
 +1 330 931 2225
 MaagAmericas@maag.com



Asia-Pacific

China

Maag-Automatik Plastics
 Machinery (Shanghai) Co., Ltd.
 Jiading District, Shanghai, 201802
 +86 21 8033 3200
 MaagChina@maag.com



Maag China Guangzhou Branch
 Huangpu District, Guangzhou
 510730
 +86 20 8985 0116
 MaagChina@maag.com



Maag Service (Taiwan) Ltd.
 Taipei City 106
 +886 2 2703 6336
 InfoTaiwan@maag.com



India

Maag Automatik
 c/o Dover India Pvt. Ltd.
 Vadodara, Gujarat
 +91 960 175286-4 (-5)
 MaagIndia@maag.com



Malaysia

Maag Service
 (Malaysia) Sdn. Bhd.
 Petaling Jaya Selangor
 +6 03 7842 2116
 InfoSEA@maag.com









Thailand

Maag Systems
 (Thailand) Limited
 A. Sriracha, Chonburi
 +66 38 190840
 Maag.BKK.Information
 @maag.com



You can find detailed information about our products in our print media at www.maag.com/brochures.



- PUMP & FILTRATION SYSTEMS >  **MAAG**
- PELLETIZING &  **GALA**  **AUTOMATIK**
- PULVERIZING SYSTEMS >  **SCHEER**  **REDUCTION**
- RECYCLING SYSTEMS >  **ETTLINGER**
- DIGITALIZATION >  **XANTEC**

www.maag.com

