

T-MAG

MAG DRIVE PUMPS



T-Mag™ MAG DRIVE PUMPS



AM • AMX

Magnetic Drive Pumps

Magnetic Drive pumps are seal-less pumps that use the technology of a drive magnet and inner magnet connected to an impeller to move fluid thru the pump. The drive magnet and inner magnet are separated by a rear casing or housing, creating a seal-less containment. Magnetic drive pumps prevent the leakage of fluid and even more importantly save you from the loss of potentially dangerous and costly liquids. With environmental concerns and EPA requirements more stringent than ever, seal-less pumps allow for zero fugitive emissions, allowing them to meet the necessary compliances. Due to their simplicity, magnetic drive pumps save maintenance time replacing seals and dealing with hazardous leaks. With only two moving parts, there is little chance for failure. Magnetic drive pumps are the answer for reliability and zero emissions.

Markets Served

Biofuels
Chemical Processing
Food and Beverage
General Industry
Pharmaceutical
Pulp and Paper
Primary Metals
Semiconductor
Wastewater
Water Treatment

Why a T-Mag Magnetic Drive Pump?

With over three decades of developing and fine-tuning magnetic drive pumps, T-Mag™ is the answer for reliability and cost-effective pumping solutions. T-Mag™ has made a name through numerous product innovations and patents that allow it to be one of the most reliable magnetic drive pumps on the market today. With two product patents featured on most of the product lines, T-Mag™ is able to withstand those harsh pumping applications. First, the patented Dry-run technology, which prevents heat build-up that often damages pump internals. Secondly, the patented Buffer system, which is designed to absorb system upsets and shock caused by harsh operating conditions. With innovations such as these, along with national distribution and service, T-Mag™ pumps are the answer for reliability.

Typical Services

Acetic Acid	Plating Chemicals
Bleach	Sodium Hydroxide
Caustic Soda	Sodium Hypochlorite
Chromic Acid	Sodium Sulfate
Hydrochloric Acid	Sulfuric Acid
Hydrofluoric Acid	Water
Hydrogen Peroxide	
Methanol	
Nitric Acid	
Phosphoric Acid	

Patented Dry-run Design

The revolutionized bearing design with dual-channel circulation on both inner and outer surfaces of the bearing contributes to rapid heat dissipation. The circulation leakage of the sealless pump is fully utilized to reinforce convectional heat transfer to thermally balance internal temperatures and prevent damage even under dry running conditions.



High Efficient Flow Design

The geometry of the impeller and casing are generated through a hydraulic design program. In addition, Computerized Fluid Dynamics (CFD) is used to control the fluid stream pattern, thus reducing hydraulic loss and increasing pump efficiency.

Integrated CAD/CAE System

Using fully computer aided design and analysis to assist product development, modern design concepts help T-Mag™ products reach the highest technical levels in industry.

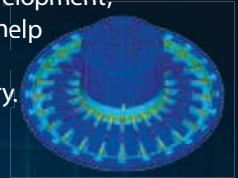

Flange Assembly

All models 1/2 HP and up come with RF type adjustable flanges. The orientation of the flange can be varied to match corresponding bolt holes to facilitate piping in stallation. The new design can also help to eliminate leakage problems caused by flange deformation.

High Performance Magnetic Coupling

We utilize magnetic field analysis to calculate magnetic torque and maximize magnet utilization to ensure sufficient torque margin to prevent decoupling.

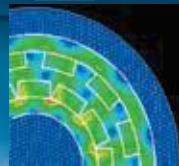

Patented Buffer System

Our innovate dynamic buffer is specially designed to absorb vibrations and shock caused by adverse operating conditions. At the same time, the dynamic buffer is self-adjusting, allowing a better face-to-face contact between the thrust ring and the wear ring, thus minimizing wear and prolonging service life.

NOTE: Buffer system and dry-run design are available on 1/2 HP (0.40 kw) through 5 HP (3.70 kw) models only.



Typical Mag Drive Flow Path

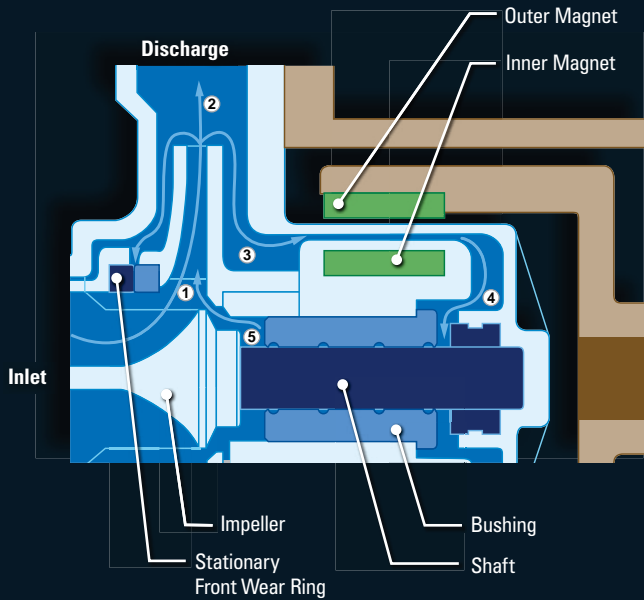

Patented Heat Dispersing Flow Path

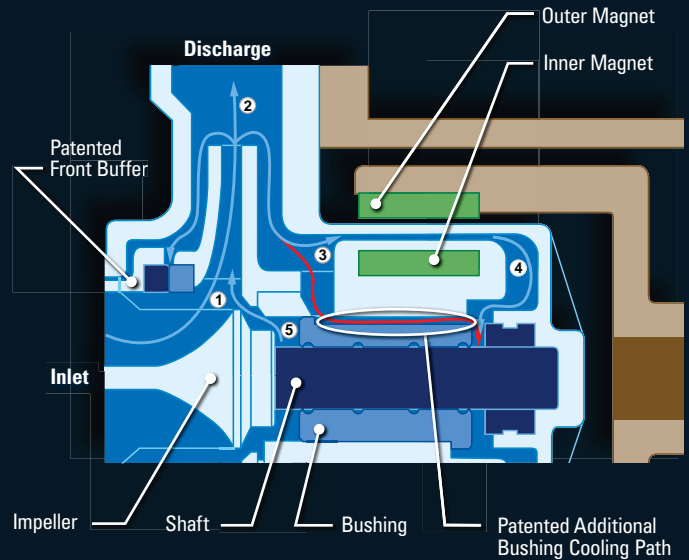

The T-Mag™ Mag-Drive pumps in the 1/2 HP (0.40 kw) through 5 HP (3.75 kw) sizes comes standard with a patented additional fluid flow path around the bushing. This additional path allows the process fluid, or air, to cool the bushing of the impeller from the outside, while continuing to offer the internal spiral cooling

channel offered on most magnetic drive centrifugal pumps today. This unique feature prevents the heat build-up that so often damages or completely disables the shaft bushing.



AM SERIES

T-Mag™

MAG DRIVE PUMPS

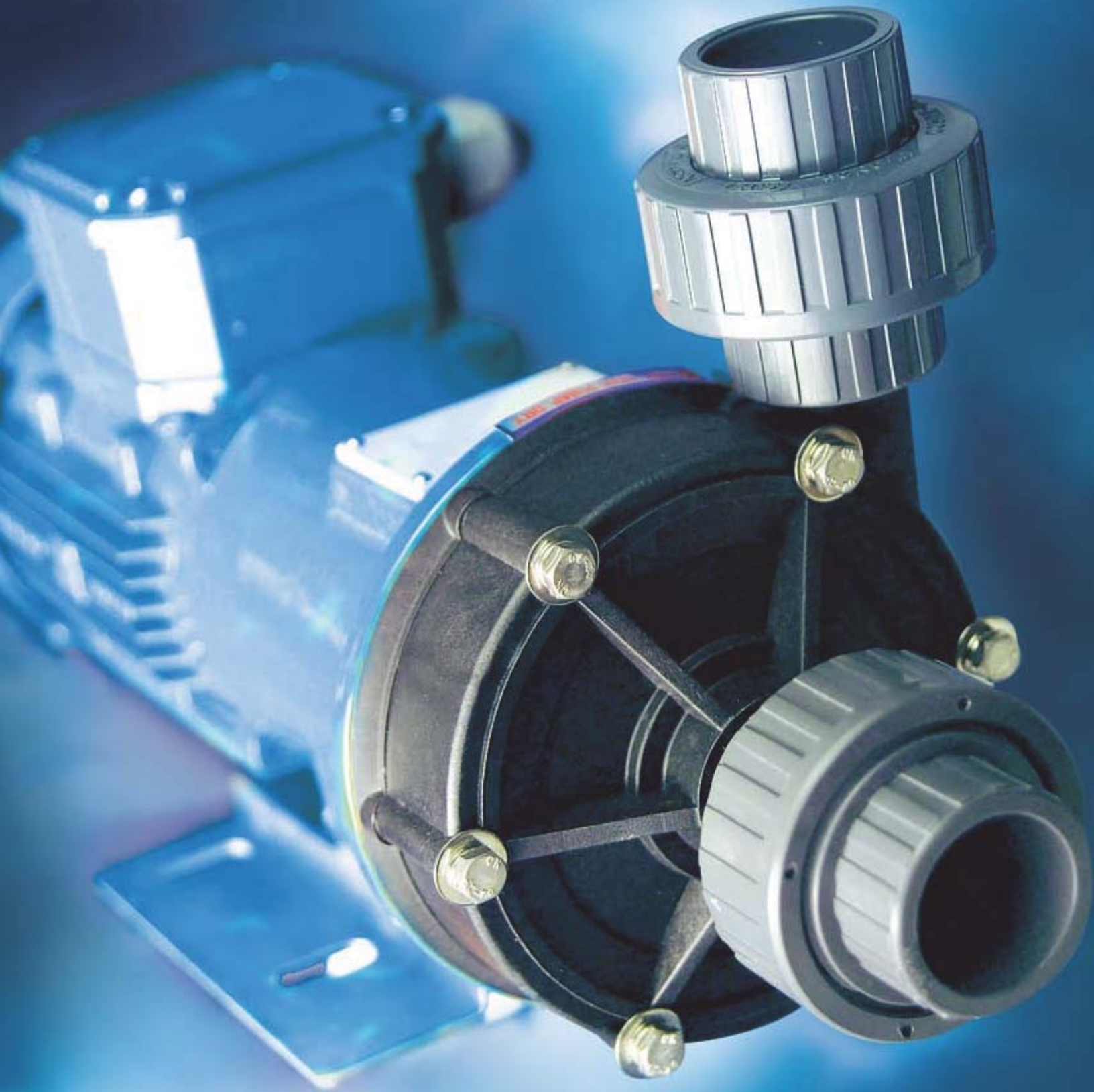

T-Mag™

MAG DRIVE PUMPS



TM1C - 1/12 HP (0.06 kW)

Dimensional Drawing:

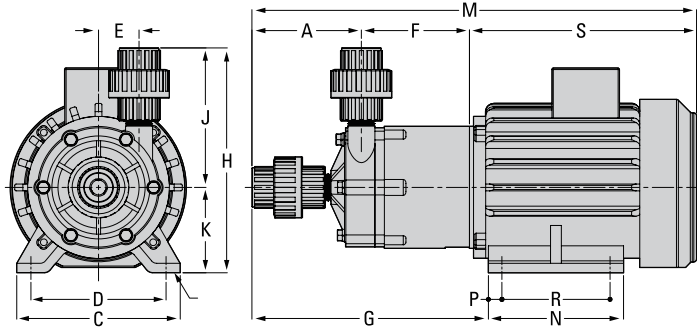

1/12 HP (0.06 kW) TM4H							
A	B	C	D	E	F	G	H
3.5(89)	5.1(130)	8.9(225)	7.7(195)	2.4(60)	5.6(142)	4.6(116)	11.3(286)

J	K	L	M	N	P	R	S
5.6(141)	4.6(118)	1.0(25)	18.4(467)	9.1(230)	1.0(25)	7.1(180)	9.3(236)

Note: The total length & weight of the pump will differ depending on the brand of the motor.

Temperature Limits:

- GF-Polypropylene: 32°F to 175°F (0°C to 79°C)
- PVDF: 10°F to 194°F (-12°C to 90°C)
- EPDM: -60°F to 280°F (-51°C to 138°C)
- Viton: -40°F to 350°F (-40°C to 177°C)

1/12 HP (0.06 kW) - 50 Hz, 2900rpm

TM1C

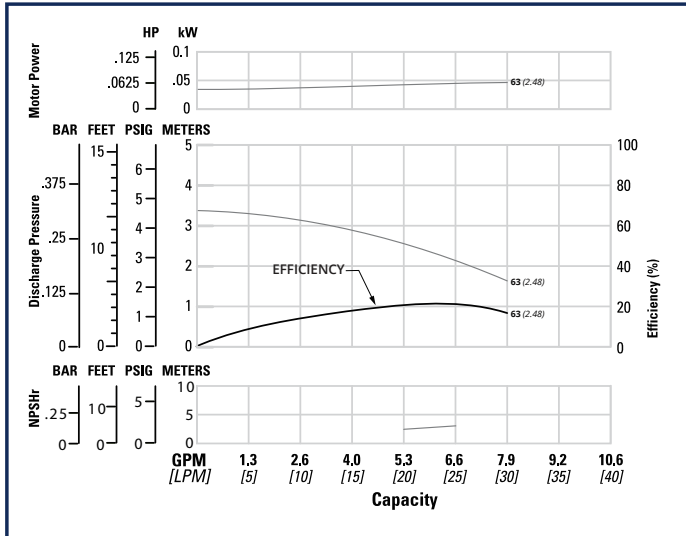

1/12 HP (0.06 kW) - 60 Hz, 3600rpm

TM1C

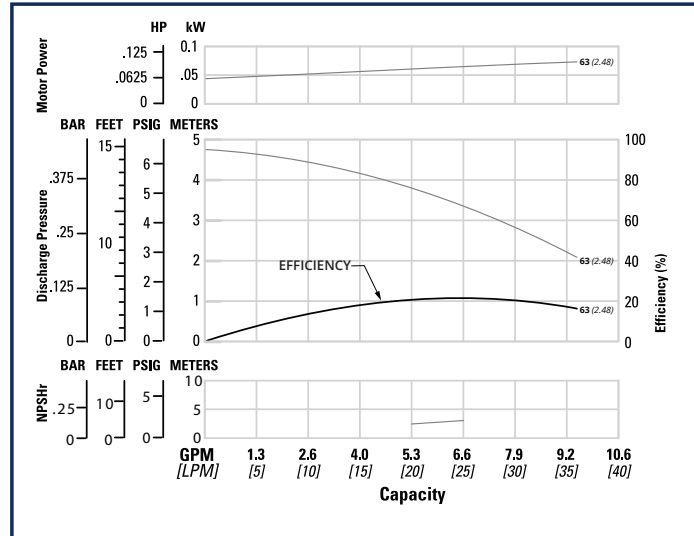

Specifications:

- Height 6.5" (166 mm)
- Width 4.8" (120 mm)
- Length..... 12.9" (329 mm)
- Ship Weight
 - GF-PP 10 lbs (5 kg)
 - PVDF 10 lbs (5 kg)
- Fluid Inlet..... 1/2" (13 mm)
- Fluid Discharge..... 1/2" (13 mm)

Rated Point:

- 50 Hz..... 4.8 gpm (18.0 lpm)
3.5 psig (0.24 bar)
- 60 Hz..... 5.3 gpm (20.0 lpm)
5.0 psig (0.34 bar)

All curves based upon pumping water at sea level, specific gravity 1.0, ambient temperature 68°F (20°C).

NOTE: Numbers shown to far right of all performance lines denote the diameter of the pump impeller [millimeters (inches)]. Consult factory for availability of impeller trim sizes other than shown.

T-Mag™ MAG DRIVE PUMPS



TM2F - 1/4 HP (0.19 kW)

Dimensional Drawing:

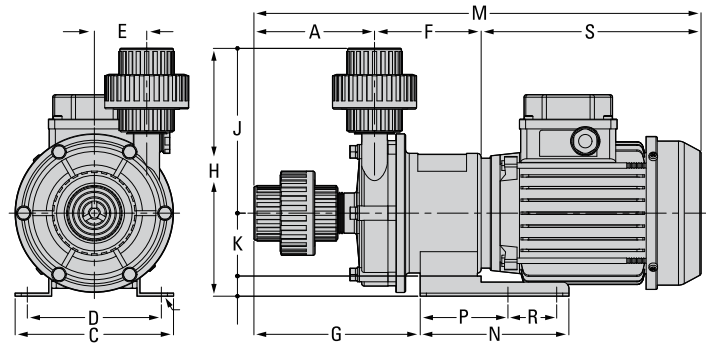

1/4 HP (0.19 kW) TM4H							
A	B	C	D	E	F	G	H
3.5(89)	5.1(130)	8.9(225)	7.7(195)	2.4(60)	5.6(142)	4.6(116)	11.3(286)
J	K	L	M	N	P	R	S
5.6(141)	4.6(118)	1.0(25)	18.4(467)	9.1(230)	1.0(25)	7.1(180)	9.3(236)

Note: The total length & weight of the pump will differ depending on the brand of the motor.

Temperature Limits:

- GF-Polypropylene: 32°F to 175°F (0°C to 79°C)
- CFR-ETFE: 0°F to 212°F (-17°C to 100°C)
- EPDM: -60°F to 280°F (-51°C to 138°C)
- Viton: -40°F to 350°F (-40°C to 177°C)

1/4 HP (0.19 kW) - 50 Hz, 2900rpm

TM2F

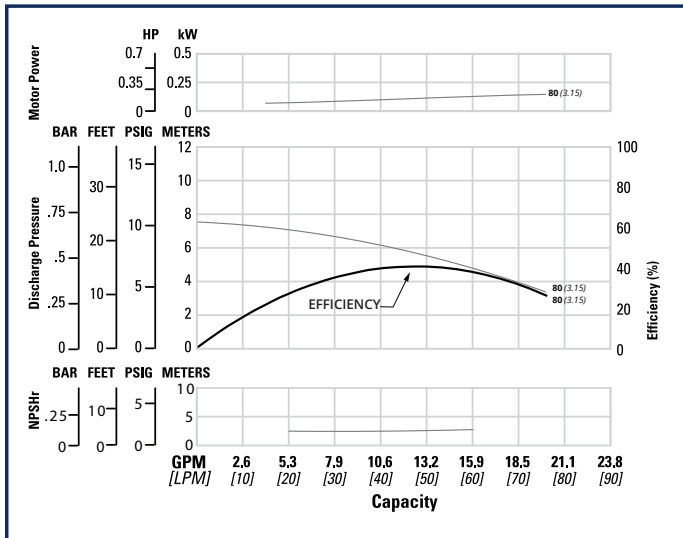

1/4 HP (0.19 kW) - 60 Hz, 3600rpm

TM2F

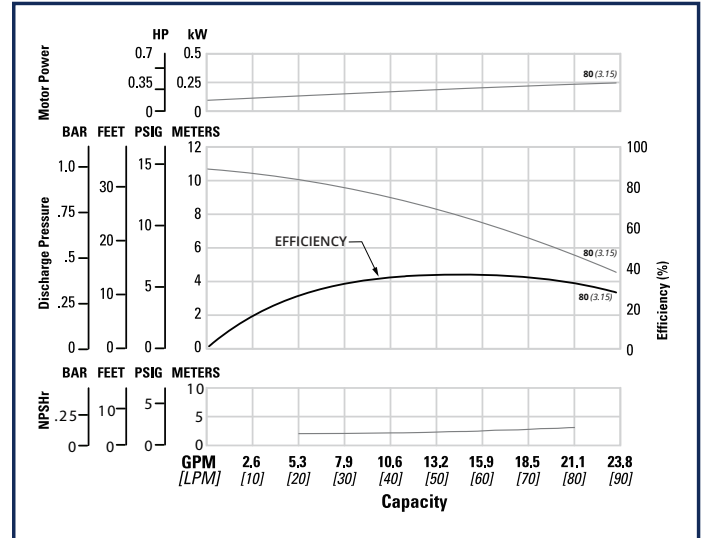

Specifications:

- Height..... 7.9" (203 mm)
- Width..... 5.1" (130 mm)
- Length..... 14.4" (367 mm)
- Ship Weight
 - GF-PP 20 lbs (10 kg)
 - CFR-ETFE 20 lbs (10 kg)
- Fluid Inlet..... 1" (25 mm)
- Fluid Discharge..... 1" (25 mm)

Rated Point:

- 50 Hz..... 15.9 gpm (60.0 lpm)
7.1 psig (0.49 bar)
- 60 Hz..... 15.9 gpm (60.0 lpm)
10.7 psig (0.74 bar)

All curves based upon pumping water at sea level, specific gravity 1.0, ambient temperature 68°F (20°C).

NOTE: Numbers shown to far right of all performance lines denote the diameter of the pump impeller [millimeters (inches)]. Consult factory for availability of impeller trim sizes other than shown.

T-Mag™ MAG DRIVE PUMPS

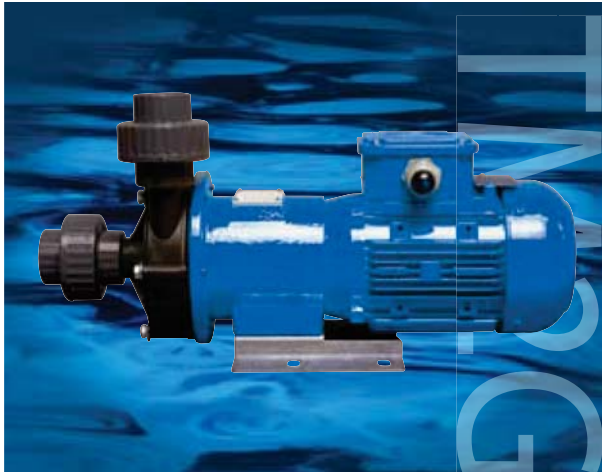

TM2G - 1/3 HP (0.25 kW)

Dimensional Drawing:

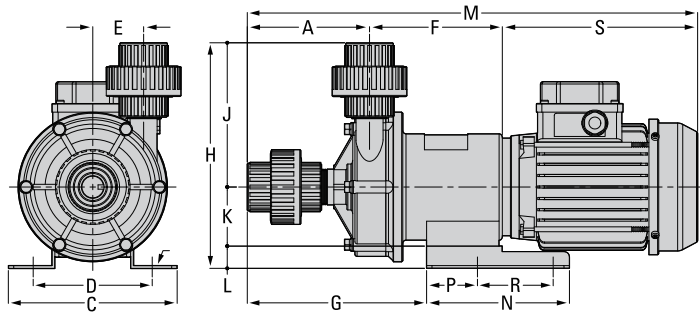

Temperature Limits:

- GF-Polypropylene: 32°F to 175°F (0°C to 79°C)
- CFR-ETFE: 0°F to 212°F (-17°C to 100°C)
- EPDM: -60°F to 280°F (-51°C to 138°C)
- Viton: -40°F to 350°F (-40°C to 177°C)

1/3 HP(0.25 kW) TM4H							
A	B	C	D	E	F	G	H
3.5 (89)	5.1 (130)	8.9 (225)	7.7 (195)	2.4 (60)	5.6 (142)	4.6 (116)	11.3 (286)
J	K	L	M	N	P	R	S
5.6 (141)	4.6 (118)	1.0 (25)	18.4 (467)	9.1 (230)	1.0 (25)	7.1 (180)	9.3 (236)

Note: The total length & weight of the pump will differ depending on the brand of the motor.

1/3 HP (0.25 kW) - 50 Hz, 2900rpm

TM2G

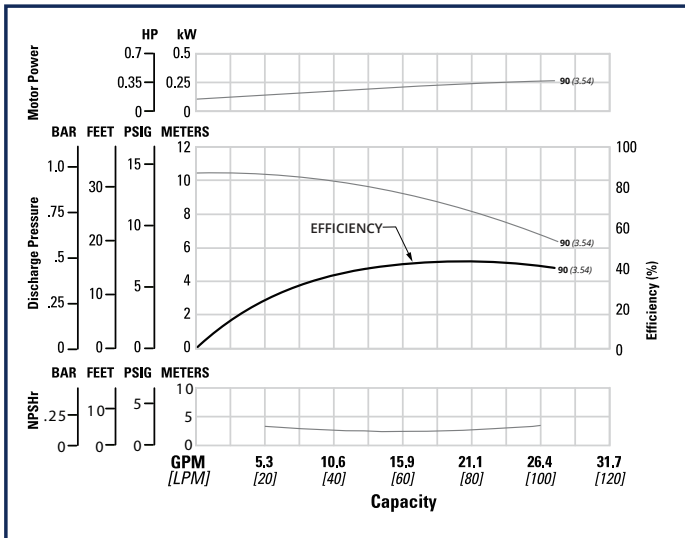

1/3 HP (0.25 kW) - 60 Hz, 3600rpm

TM2G

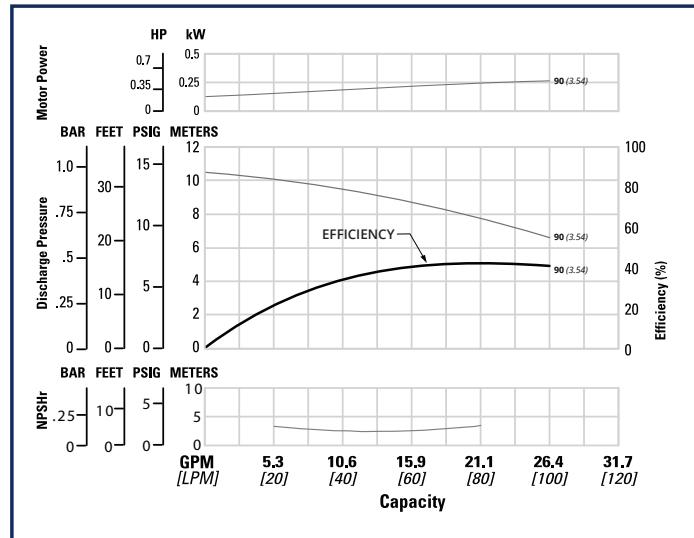

Specifications:

- Height..... 8.2" (208 mm)
- Width..... 6.1" (156 mm)
- Length..... 16.3" (416 mm)
- Ship Weight
 - GF-PP 24 lbs (11 kg)
 - CFR-ETFE 24 lbs (11 kg)
- Fluid Inlet..... 1" (25 mm)
- Fluid Discharge..... 1" (25 mm)

Rated Point:

- 50 Hz..... 21.1 gpm (80.0 lpm)
8.6 psig (0.59 bar)
- 60 Hz..... 21.1 gpm (80.0 lpm)
10.3 psig (0.71 bar)

All curves based upon pumping water at sea level, specific gravity 1.0, ambient temperature 68°F (20°C).

NOTE: Numbers shown to far right of all performance lines denote the diameter of the pump impeller [millimeters (inches)]. Consult factory for availability of impeller trim sizes other than shown.

T-Mag™

MAG DRIVE PUMPS

AMX SERIES



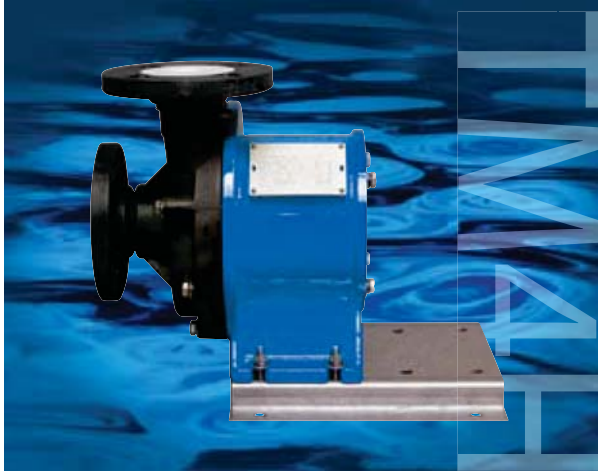

TM4H - 1/2 HP (0.40 kW)

Dimensional Drawing:

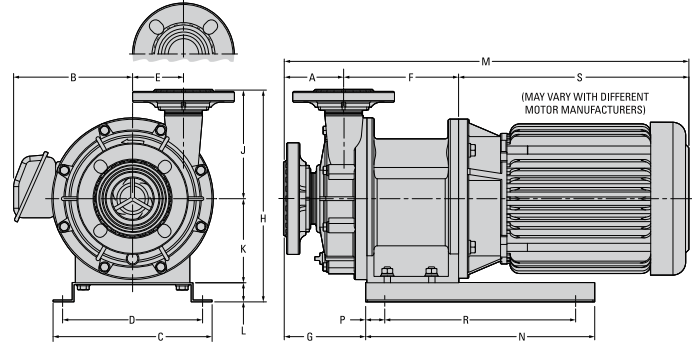

1/2 HP (0.40 kW) TM4H							
A	B	C	D	E	F	G	H
3.5 (89)	5.1 (130)	8.9 (225)	7.7 (195)	2.4 (60)	5.6 (142)	4.6 (116)	11.3 (286)
J	K	L	M	N	P	R	S
5.6 (141)	4.6 (118)	1.0 (25)	18.4 (467)	9.1 (230)	1.0 (25)	7.1 (180)	9.3 (236)

Note: The total length & weight of the pump will differ depending on the brand of the motor.

Temperature Limits:

- GF-Polypropylene: 32°F to 175°F (0°C to 79°C)
- CFR-ETFE: 0°F to 212°F (-17°C to 100°C)
- EPDM: -60°F to 280°F (-51°C to 138°C)
- Viton: -40°F to 350°F (-40°C to 177°C)

1/2 HP (0.40 kW) - 50 Hz, 2900rpm

TM4H

1/2 HP (0.40 kW) - 60 Hz, 3600rpm

TM4H

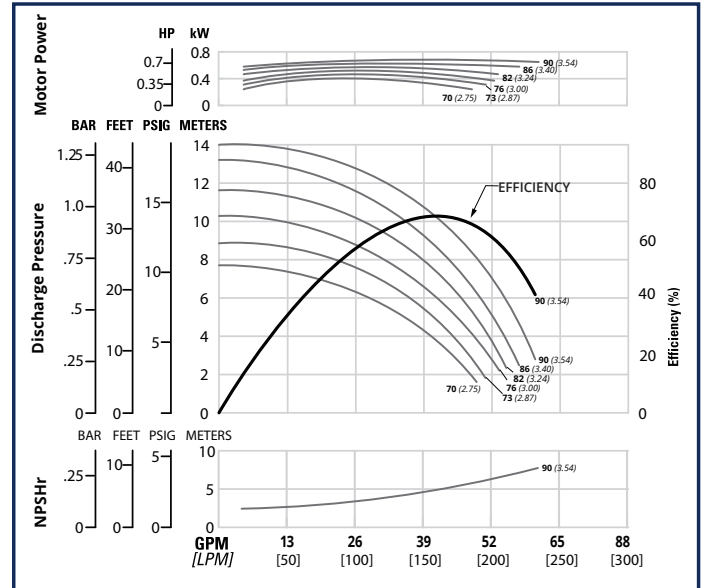
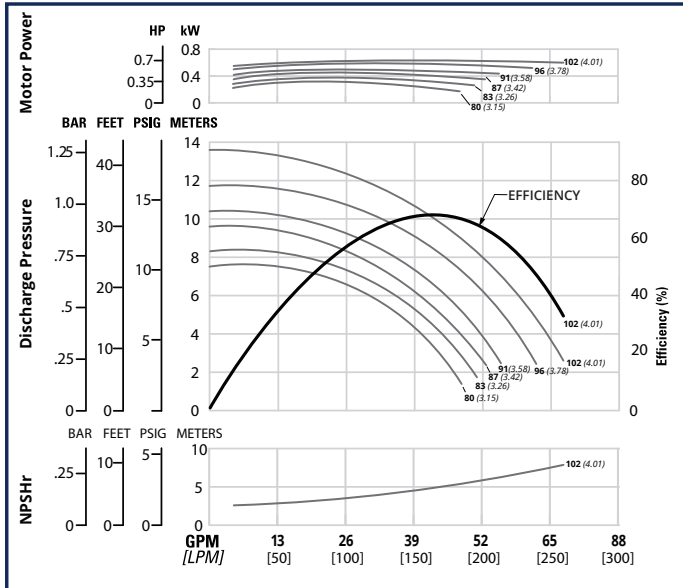

Specifications:

- Height..... 11.3" (286 mm)
- Width..... 10.2" (260 mm)
- Length..... 18.4" (467 mm)
- Ship Weight
 - GF-PP 40 lbs (18 kg)
 - CFR-ETFE 42 lbs (19 kg)
- Fluid Inlet..... 1-1/2" (38 mm)
- Fluid Discharge..... 1-1/2" (38 mm)

Rated Point:

- 50 Hz..... 43 gpm (195 lpm)
- 14.0 psig (0.96 bar)
- 60 Hz..... 43 gpm (195 lpm)
- 14.0 psig (0.96 bar)

All curves based upon pumping water at sea level, specific gravity 1.0, ambient temperature 68°F (20°C).

NOTE: Numbers shown to far right of all performance lines denote the diameter of the pump impeller [millimeters (inches)]. Consult factory for availability of impeller trim sizes other than shown.

T-Mag™ MAG DRIVE PUMPS



TM4K - 1 HP (0.75 kW)

Dimensional Drawing:

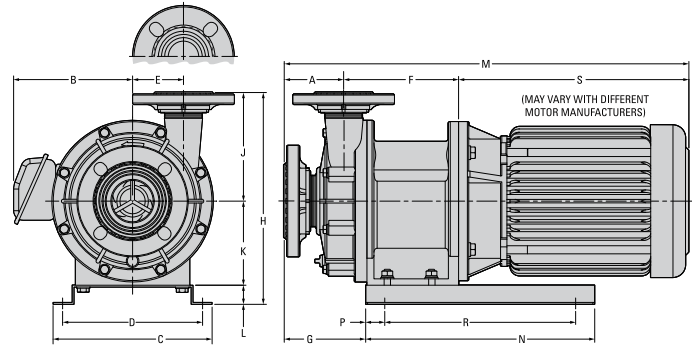

1 HP (0.75 kW) TM4K							
A	B	C	D	E	F	G	H
5.2(131)	5.6(142)	6.3(160)	5.1(130)	2.8(72)	5.7(146)	5.9(150)	10.1(256)
J	K	L	M	N	P	R	S
5.6(141)	3.3(85)	1.2(30)	18.9(481)	8.3(210)	1.4(35)	5.1(130)	9.1(232)

Note: The total length & weight of the pump will differ depending on the brand of the motor.

Temperature Limits:

- GF-Polypropylene: 32°F to 175°F (0°C to 79°C)
- CFR-ETFE: 0°F to 212°F (-17°C to 100°C)
- EPDM: -60°F to 280°F (-51°C to 138°C)
- Viton: -40°F to 350°F (-40°C to 177°C)

1 HP (0.75 kW) - 50 Hz, 2900rpm

TM4K

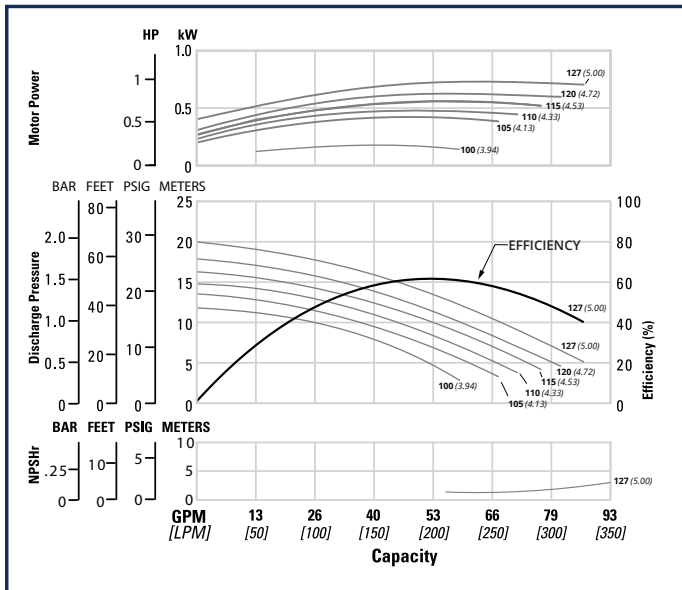

1 HP (0.75 kW) - 60 Hz, 3600rpm

TM4K

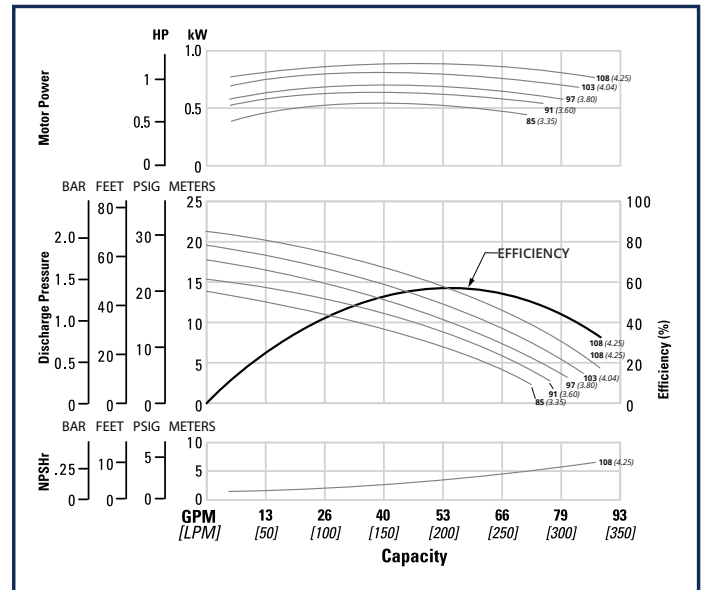

Specifications:

- Height..... 10.1" (256 mm)
- Width..... 11.2" (284 mm)
- Length..... 18.9" (481 mm)
- Ship Weight
 - GF-PP 53 lbs (24 kg)
 - CFR-ETFE 55 lbs (25 kg)
- Fluid Inlet..... 1-1/2" (38 mm)
- Fluid Discharge..... 1-1/2" (38 mm)

Rated Point:

- 50 Hz..... 45 gpm (204 lpm)
22.8 psig (1.57 bar)
- 60 Hz..... 53 gpm (240 lpm)
21.9 psig (1.51 bar)

All curves based upon pumping water at sea level, specific gravity 1.0, ambient temperature 68°F (20°C).

NOTE: Numbers shown to far right of all performance lines denote the diameter of the pump impeller [millimeters (inches)]. Consult factory for availability of impeller trim sizes other than shown.

T-Mag™ MAG DRIVE PUMPS



TM6L - 2 HP (1.50 kW)

Dimensional Drawing:

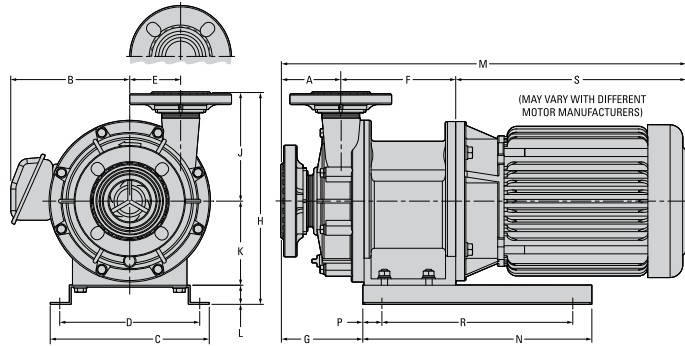

2 HP (1.5 kW) TM6L							
A	B	C	D	E	F	G	H
3.5(90)	16.1(155)	10.2(260)	8.0(204)	3.1(80)	6.3(160)	5.4(138)	11.1(281)
J	K	L	M	N	P	R	S
6.3(161)	3.5(90)	1.2(30)	22.2(564)	11.8(300)	0.8(20)	7.9(200)	12.2(311)

Note: The total length & weight of the pump will differ depending on the brand of the motor.

Temperature Limits:

- GF-Polypropylene: 32°F to 175°F (0°C to 79°C)
- CFR-ETFE: 0°F to 212°F (-17°C to 100°C)
- EPDM: -60°F to 280°F (-51°C to 138°C)
- Viton: -40°F to 350°F (-40°C to 177°C)

2 HP (1.50 kW) - 50 Hz, 2900rpm

TM6L

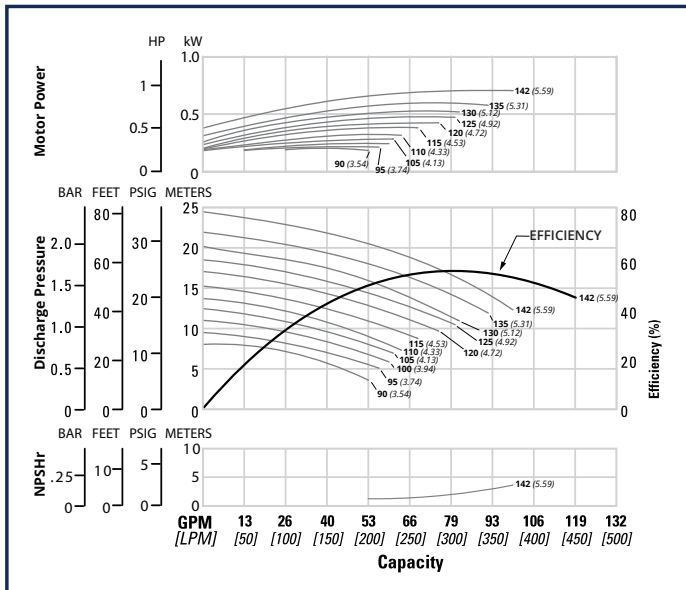

2 HP (1.50 kW) - 60 Hz, 3600rpm

TM6L

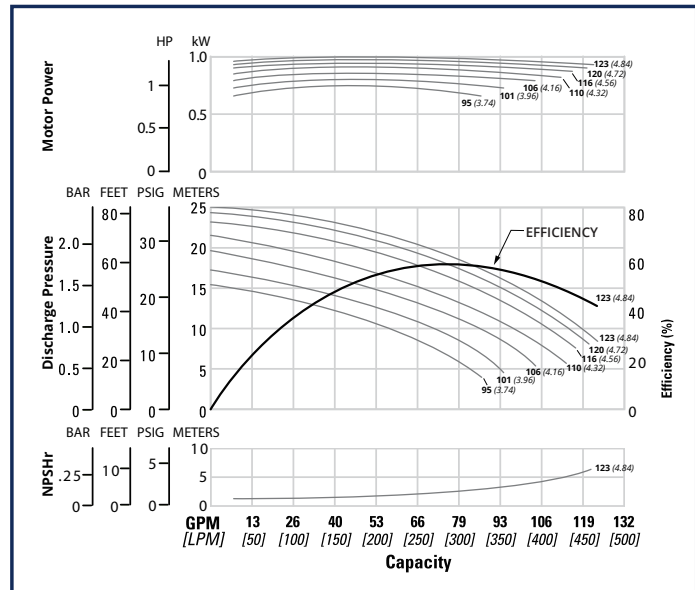

Specifications:

- Height..... 11.1" (281 mm)
- Width..... 12.0" (305 mm)
- Length..... 22.2" (564 mm)
- Ship Weight
 - GF-PP 77 lbs (35 kg)
 - CFR-ETFE 79 lbs (36 kg)
- Fluid Inlet..... 2" (51 mm)
- Fluid Discharge..... 1-1/2" (38 mm)

Rated Point:

- 50 Hz..... 75 gpm (340 lpm)
25.0 psig (1.72 bar)
- 60 Hz..... 85 gpm (386 lpm)
26.0 psig (1.79 bar)

All curves based upon pumping water at sea level, specific gravity 1.0, ambient temperature 68°F (20°C).

NOTE: Numbers shown to far right of all performance lines denote the diameter of the pump impeller [millimeters (inches)]. Consult factory for availability of impeller trim sizes other than shown.

T-Mag™ MAG DRIVE PUMPS



TM6M - 3 HP (2.20 kW)

Dimensional Drawing:

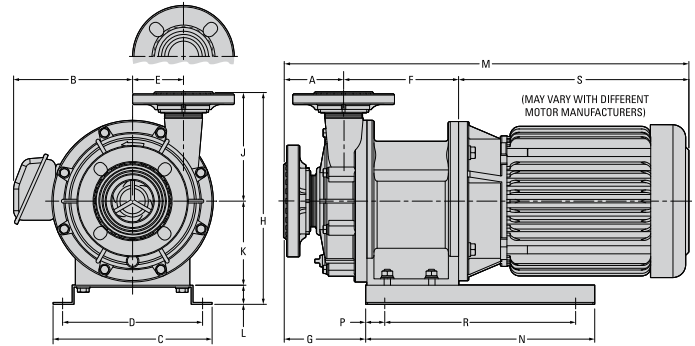

3 HP (2.20 kW) TM6M							
A	B	C	D	E	F	G	H
3.5(90)	6.1(155)	10.2(260)	8.0(204)	3.1(80)	6.3(160)	5.4(138)	11.1(281)
J	K	L	M	N	P	R	S
6.3(161)	3.5(90)	1.2(30)	22.2(564)	11.8(300)	0.8(20)	7.9(200)	12.2(311)

Note: The total length & weight of the pump will differ depending on the brand of the motor.

Temperature Limits:

- GF-Polypropylene: 32°F to 175°F (0°C to 79°C)
- CFR-ETFE: 0°F to 212°F (-17°C to 100°C)
- EPDM: -60°F to 280°F (-51°C to 138°C)
- Viton: -40°F to 350°F (-40°C to 177°C)

3 HP (2.20 kW) - 50 Hz, 2900rpm

TM6M

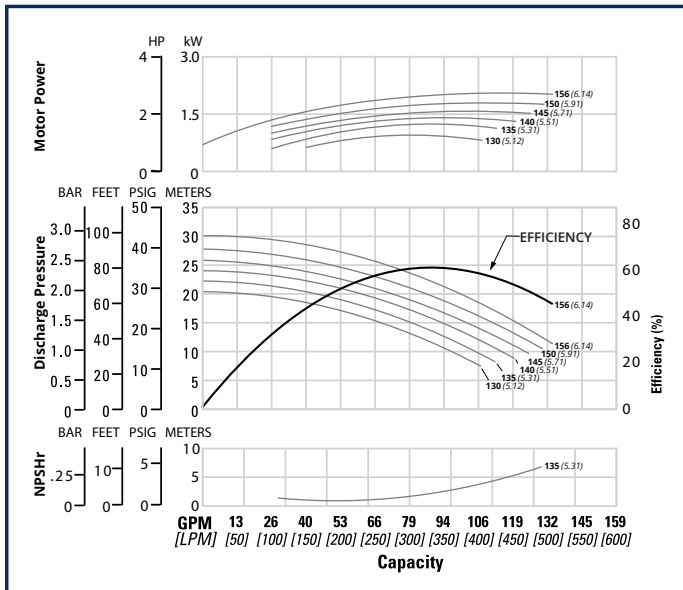

3 HP (2.20 kW) - 60 Hz, 3600rpm

TM6M

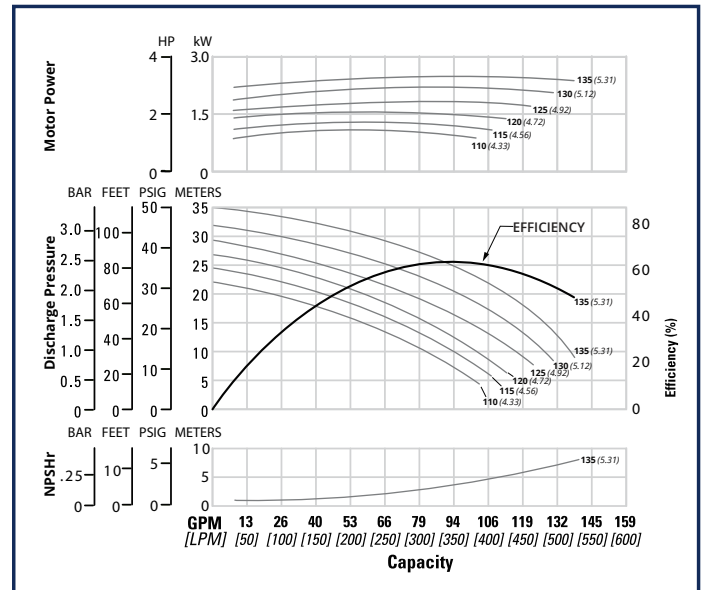

Specifications:

- Height..... 11.1" (281 mm)
- Width..... 12.0" (305 mm)
- Length..... 22.2" (564 mm)
- Ship Weight
 - GF-PP 82 lbs (37 kg)
 - CFR-ETFE 84 lbs (37 kg)
- Fluid Inlet..... 2" (51 mm)
- Fluid Discharge..... 1-1/2" (38 mm)

Rated Point:

- 50 Hz..... 77 gpm (350 lpm)
36.7 psig (2.53 bar)
- 60 Hz..... 96 gpm (409 lpm)
37.3 psig (2.57 bar)

All curves based upon pumping water at sea level, specific gravity 1.0, ambient temperature 68°F (20°C).

NOTE: Numbers shown to far right of all performance lines denote the diameter of the pump impeller [millimeters (inches)]. Consult factory for availability of impeller trim sizes other than shown.

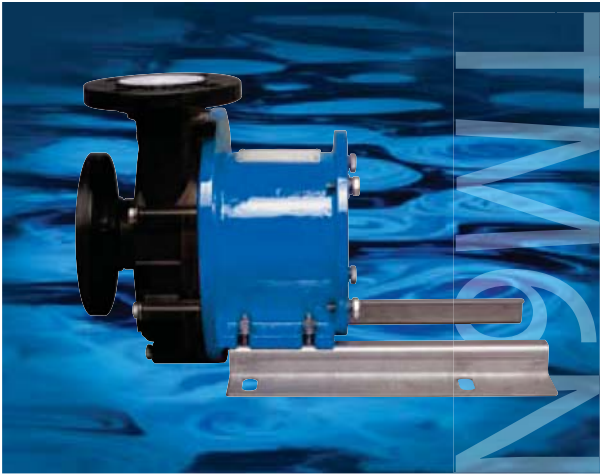

TM6N - 5 HP (3.70 kW)

Dimensional Drawing:

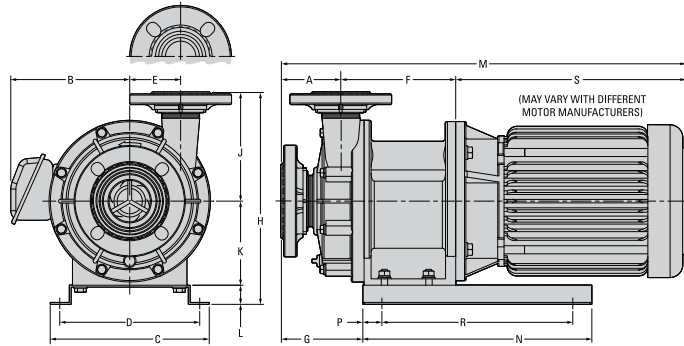

5 HP (3.70 kW) TM6N							
A	B	C	D	E	F	G	H
3.5(90)	7.4(187)	9.8(250)	8.7(220)	3.1(80)	6.9(175)	4.7(119)	12.7(323)

J	K	L	M	N	P	R	S
6.3(161)	5.2(132)	1.2(30)	24.7(627)	14.2(360)	1.2(30)	11.8(300)	14.3(362)

Note: The total length & weight of the pump will differ depending on the brand of the motor.

Temperature Limits:

- GF-Polypropylene: 32°F to 175°F (0°C to 79°C)
- CFR-ETFE: 0°F to 212°F (-17°C to 100°C)
- EPDM: -60°F to 280°F (-51°C to 138°C)
- Viton: -40°F to 350°F (-40°C to 177°C)

5 HP (3.70 kW) - 50 Hz, 2900rpm

TM6N

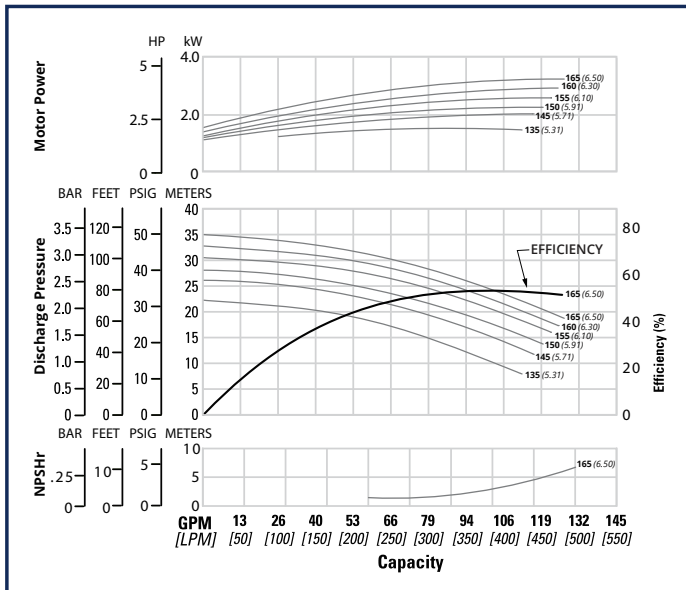

5 HP (3.70 kW) - 60 Hz, 3600rpm

TM6N

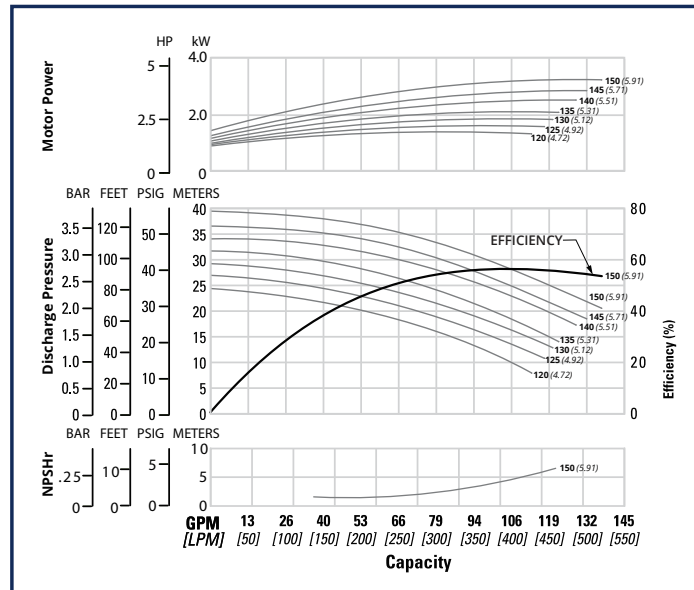

Specifications:

- Height..... 12.7" (323 mm)
- Width..... 13.3"(337 mm)
- Length..... 24.7" (627 mm)
- Ship Weight
 - GF-PP 117lbs (53 kg)
 - CFR-ETFE 119lbs (54 kg)
- Fluid Inlet..... 2" (51 mm)
- Fluid Discharge..... 1-1/2" (38 mm)

Rated Point:

- 50 Hz..... 100 gpm (454 lpm)
35.0 psig (2.41 bar)
- 60 Hz..... 105 gpm (477 lpm)
40.0 psig (2.75 bar)

All curves based upon pumping water at sea level, specific gravity 1.0, ambient temperature 68°F (20°C).

NOTE: Numbers shown to far right of all performance lines denote the diameter of the pump impeller [millimeters (inches)]. Consult factory for availability of impeller trim sizes other than shown.

T-Mag™ MAG DRIVE PUMPS



TM10N - 5 HP (3.70 kW)

Dimensional Drawing:

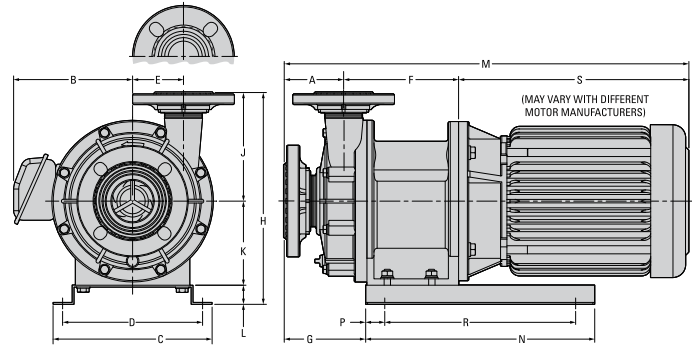

5 HP (3.70 kW) TM10N							
A	B	C	D	E	F	G	H
3.7(94)	7.4(187)	9.8(250)	8.7(220)	3.1(80)	7.1(180)	5.0(128)	12.7(323)
J	K	L	M	N	P	R	S
6.7(171)	5.2(132)	1.2(30)	25.0(636)	14.2(360)	1.2(30)	11.8(300)	14.3(362)

Note: The total length & weight of the pump will differ depending on the brand of the motor.

Temperature Limits:

- GF-Polypropylene: 32°F to 175°F (0°C to 79°C)
- CFR-ETFE: 0°F to 212°F (-17°C to 100°C)
- EPDM: -60°F to 280°F (-51°C to 138°C)
- Viton: -40°F to 350°F (-40°C to 177°C)

5 HP (3.70 kW) - 50 Hz, 2900rpm

TM10N

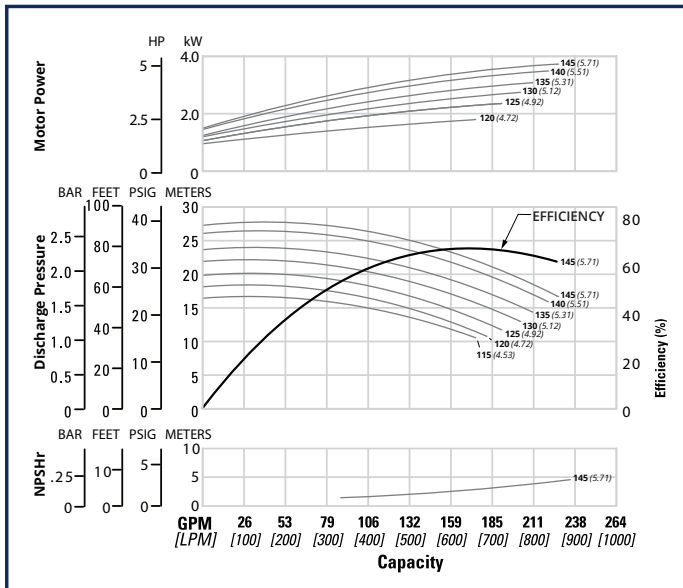

5 HP (3.70 kW) - 60 Hz, 3600rpm

TM10N

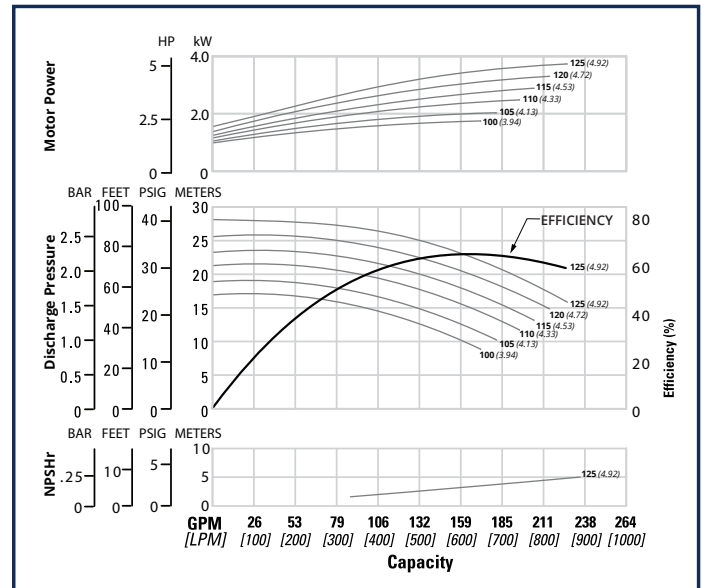

Specifications:

- Height..... 13.1" (333 mm)
- Width..... 13.7" (347 mm)
- Length..... 25.0" (636 mm)
- Ship Weight
 - GF-PP 117 lbs (53 kg)
 - CFR-ETFE 119 lbs (54 kg)
- Fluid Inlet..... 2-1/2" (64 mm)
- Fluid Discharge..... 2" (51 mm)

Rated Point:

- 50 Hz..... 150 gpm (681 lpm)
34.0 psig (2.49 bar)
- 60 Hz..... 159 gpm (722 lpm)
33.0 psig (2.34 bar)

All curves based upon pumping water at sea level, specific gravity 1.0, ambient temperature 68°F (20°C).

NOTE: Numbers shown to far right of all performance lines denote the diameter of the pump impeller [millimeters (inches)]. Consult factory for availability of impeller trim sizes other than shown.



21365 Gateway Court • Brookfield, WI 53045
(855) 848-TMAG (8624) Fax (262) 784-9749
sales@tmagpumps.com
www.tmagpumps.com

Your Authorized Distributor:
sales@tmagpumps.com

Printed in the U.S.A.

Copyright 2017, Anderson Process