

Series: <b>NKZ</b>	Discharge Bore: <b>80 - 150mm</b>	Motor Output / Pole: <b>2.2 - 11kW / 4-pole</b>
-----------------------	--------------------------------------	--



The NKZ-series is a submersible three-phase cast iron heavy-duty slurry pump driven by a 4-pole motor. It is equipped with an agitator that assists smooth suction of settled matters. The side discharge, spiral design allows smoother passage of the sucked solid matters. The motor is cooled by a water jacket that assures efficient motor cooling even when it operates with its motor exposed to air.

**Selection Table**

Model	Discharge Bore mm	Motor Output kW	Phase	Starting Method	Pole	Dry Weight kg
NKZ32.2	80	2.2	3-phase	Direct on Line	4	102
NKZ33.7	80	3.7	3-phase	Direct on Line	4	107
NKZ35.5	80	5.5	3-phase	Direct on Line	4	146
NKZ43.7	100	3.7	3-phase	Direct on Line	4	104
NKZ45.5	100	5.5	3-phase	Direct on Line	4	129
NKZ411	100	11	3-phase	Direct on Line	4	217
NKZ611	150	11	3-phase	Direct on Line	4	210

**Performance Curves**

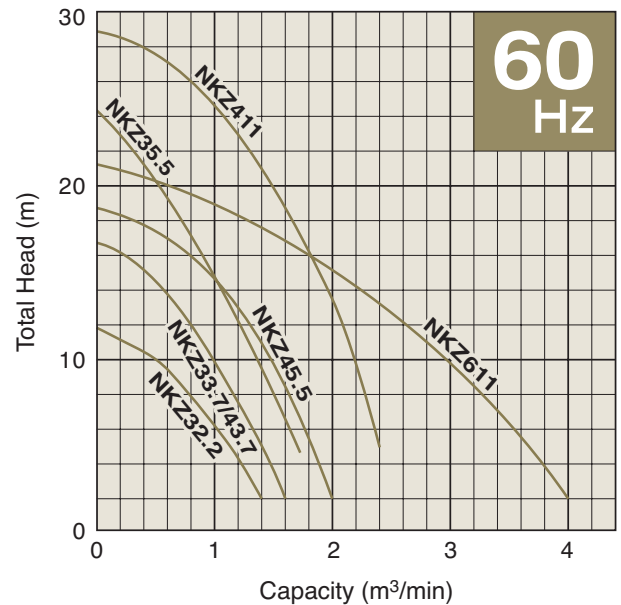
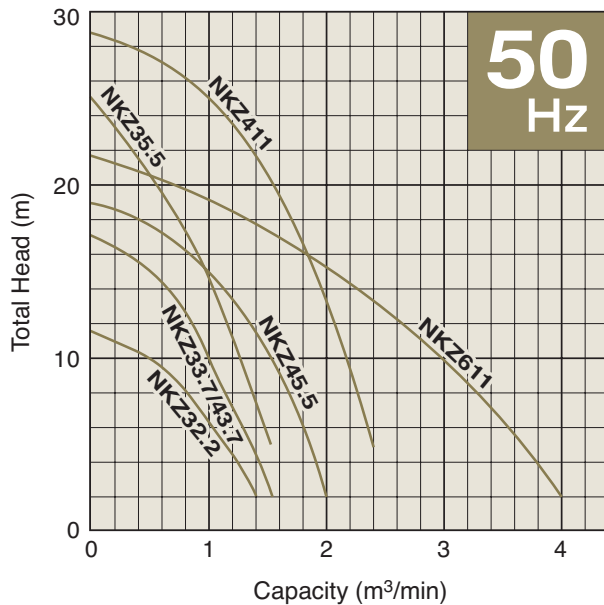

SPECIFICATIONS	Model	NKZ32.2							
		NKZ-series 2.2kW, 3-phase							
<p><b>Type of Pump</b> Submersible slurry pump for construction and foundation works, mining, and quarries, etc.</p> <p><b>Water Jacket</b> Equipped with a water jacket, around the motor frame. A portion of the pumped liquid is allowed to flow into the water jacket to cool the motor.</p> <p><b>Type of Fluid</b> Water containing sand, mud, and slurry</p> <p>Temperature: 0 to 40°C</p> <p><b>Discharge Bore &amp; Connection</b> 80mm, Hose Coupling</p> <p><b>Motor Output</b> 2.2kW</p> <p><b>Power Supply</b> Three-phase</p> <p><b>Starting Method</b> Direct on Line (Star-Delta available on special request)</p> <p><b>Motor</b> Continuous-duty rated, dry-type induction motor</p> <p>Insulation Class: F Degree of Protection: IP68</p> <p>No. of Poles &amp; Speed (Synchronous Speed) 4-pole, 1500/1800min<sup>-1</sup> (50/60Hz)</p> <p>Power Supply Voltages &amp; Rated Currents</p> <table border="0"> <tr> <td>50Hz</td> <td>60Hz</td> </tr> <tr> <td>380V – 5.7A</td> <td>220V – 9.7A</td> </tr> <tr> <td>400V – 5.5A</td> <td>380V – 5.5A</td> </tr> <tr> <td>415V – 5.5A</td> <td>440V – 4.9A</td> </tr> </table> <p><b>Power Cable</b> Sheath: Chloroprene rubber Standard Length: 8m 200 to 600V supply: 1 x 4 x 1.5mm<sup>2</sup>, O.D. 11.3mm (60245 IEC 66) or 1 x 4 x 2.0mm<sup>2</sup>, O.D. 14.4mm</p> <p><b>Dry Weight</b> (excluding cable) 102kg</p>	50Hz	60Hz	380V – 5.7A	220V – 9.7A	400V – 5.5A	380V – 5.5A	415V – 5.5A	440V – 4.9A	<p><b>Impeller</b> Semi-open impeller made of ductile cast iron</p> <p>Solids Passage 50Hz – <math>\phi</math>30mm 60Hz – <math>\phi</math>30mm</p> <p><b>Agitator</b> Ductile cast iron</p> <p><b>Cable Entry with Anti-Wicking Block</b> Watertight cable entry with strain-relief device. The anti-wicking block prevents water incursion due to capillary action should the power cable be damaged or the end submerged.</p> <p><b>Bearing</b> Permanently lubricated, deep-groove, double-shielded C3 ball bearings</p> <p><b>Shaft</b> 420 stainless steel</p> <p><b>Shaft Seal (Mechanical Seal)</b> Furnished with a double-face mechanical seal located in oil chamber. Both upper and lower seal faces always run in a clean environment.</p> <p>Upper Seal Face: SiC + SiC Lower Seal Face: SiC + SiC</p> <p><b>Oil Seal (Lip Seal)</b> Used as a “Dust Seal”, it protects the mechanical seal from abrasive particles.</p> <p><b>OIL LIFTER</b> Equipped in oil chamber. It forcibly supplies lubricating oil to the mechanical seal and continues to supply the oil to the upper seal faces even if lubricant falls below the rated volume.</p> <p>Type of Lubricating Oil &amp; Volume Turbine Oil (ISO VG32), 700ml</p> <p><b>Motor Protection Device</b> A circle thermal protector built in the motor housing. Directly cuts the motor circuit if excessive heat builds up or an overcurrent condition occurs in the motor.</p>
50Hz	60Hz								
380V – 5.7A	220V – 9.7A								
400V – 5.5A	380V – 5.5A								
415V – 5.5A	440V – 4.9A								
<p><b>Optional Accessory</b></p> <p><b>Male Threaded Coupling</b></p>	<p><b>Special Specifications</b></p> <p><b>High Temperature Liquids Version (60-80°C)</b></p>								

SPECIFICATIONS	Model	NKZ33.7	NKZ-series
			3.7kW, 3-phase

<p><b>Type of Pump</b> Submersible slurry pump for construction and foundation works, mining, and quarries, etc.</p> <p><b>Water Jacket</b> Equipped with a water jacket, around the motor frame. A portion of the pumped liquid is allowed to flow into the water jacket to cool the motor.</p> <p><b>Type of Fluid</b> Water containing sand, mud, and slurry</p> <p>Temperature: 0 to 40°C</p> <p><b>Discharge Bore &amp; Connection</b> 80mm, Hose Coupling</p> <p><b>Motor Output</b> 3.7kW</p> <p><b>Power Supply</b> Three-phase</p> <p><b>Starting Method</b> Direct on Line (Star-Delta available on special request)</p> <p><b>Motor</b> Continuous-duty rated, dry-type induction motor</p> <p>Insulation Class: F Degree of Protection: IP68</p> <p>No. of Poles &amp; Speed (Synchronous Speed) 4-pole, 1500/1800min<sup>-1</sup> (50/60Hz)</p> <p>Power Supply Voltages &amp; Rated Currents</p> <table border="0"> <tr> <td>50Hz</td> <td>60Hz</td> </tr> <tr> <td>380V – 8.8A</td> <td>220V – 15.4A</td> </tr> <tr> <td>400V – 8.6A</td> <td>380V – 8.7A</td> </tr> <tr> <td>415V – 8.4A</td> <td>440V – 7.6A</td> </tr> </table> <p><b>Power Cable</b> Sheath: Chloroprene rubber Standard Length: 8m 380 to 600V supply: 1 x 4 x 1.5mm<sup>2</sup>, O.D. 11.3mm (60245 IEC 66) or 1 x 4 x 2.0mm<sup>2</sup>, O.D. 14.4mm 200 to 240V supply: 1 x 4 x 2.5mm<sup>2</sup>, O.D. 12.4mm (60245 IEC 66) or 1 x 4 x 2.0mm<sup>2</sup>, O.D. 14.4mm</p> <p><b>Dry Weight (excluding cable)</b> 107kg</p>	50Hz	60Hz	380V – 8.8A	220V – 15.4A	400V – 8.6A	380V – 8.7A	415V – 8.4A	440V – 7.6A	<p><b>Impeller</b> Semi-open impeller made of ductile cast iron</p> <p>Solids Passage 50Hz – <math>\phi</math>30mm 60Hz – <math>\phi</math>30mm</p> <p><b>Agitator</b> Ductile cast iron</p> <p><b>Cable Entry with Anti-Wicking Block</b> Watertight cable entry with strain-relief device. The anti-wicking block prevents water incursion due to capillary action should the power cable be damaged or the end submerged.</p> <p><b>Bearing</b> Permanently lubricated, deep-groove, double-shielded C3 ball bearings</p> <p><b>Shaft</b> 420 stainless steel</p> <p><b>Shaft Seal (Mechanical Seal)</b> Furnished with a double-face mechanical seal located in oil chamber. Both upper and lower seal faces always run in a clean environment.</p> <p>Upper Seal Face: SiC + SiC Lower Seal Face: SiC + SiC</p> <p><b>Oil Seal (Lip Seal)</b> Used as a “Dust Seal”, it protects the mechanical seal from abrasive particles.</p> <p><b>OIL LIFTER</b> Equipped in oil chamber. It forcibly supplies lubricating oil to the mechanical seal and continues to supply the oil to the upper seal faces even if lubricant falls below the rated volume.</p> <p>Type of Lubricating Oil &amp; Volume Turbine Oil (ISO VG32), 700ml</p> <p><b>Motor Protection Device</b> A circle thermal protector built in the motor housing. Directly cuts the motor circuit if excessive heat builds up or an overcurrent condition occurs in the motor.</p>
50Hz	60Hz								
380V – 8.8A	220V – 15.4A								
400V – 8.6A	380V – 8.7A								
415V – 8.4A	440V – 7.6A								

<p><b>Optional Accessory</b></p> <p><b>Male Threaded Coupling</b></p>	<p><b>Special Specifications</b></p> <p><b>High Temperature Liquids Version (60-80°C)</b></p>
---	---

SPECIFICATIONS	Model	NKZ35.5	NKZ-series
			5.5kW, 3-phase

<p><b>Type of Pump</b> Submersible slurry pump for construction and foundation works, mining, and quarries, etc.</p> <p><b>Water Jacket</b> Equipped with a water jacket, around the motor frame. A portion of the pumped liquid is allowed to flow into the water jacket to cool the motor.</p> <p><b>Type of Fluid</b> Water containing sand, mud, and slurry</p> <p>Temperature: 0 to 40°C</p> <p><b>Discharge Bore &amp; Connection</b> 80mm, Hose Coupling</p> <p><b>Motor Output</b> 5.5kW</p> <p><b>Power Supply</b> Three-phase</p> <p><b>Starting Method</b> Direct on Line (Star-Delta available on special request)</p> <p><b>Motor</b> Continuous-duty rated, dry-type induction motor</p> <p>Insulation Class: F Degree of Protection: IP68</p> <p>No. of Poles &amp; Speed (Synchronous Speed) 4-pole, 1500/1800min<sup>-1</sup> (50/60Hz)</p> <p>Power Supply Voltages &amp; Rated Currents</p> <table border="0"> <tr> <td>50Hz</td> <td>60Hz</td> </tr> <tr> <td>380V – 12.5A</td> <td>220V – 21.0A</td> </tr> <tr> <td>400V – 12.1A</td> <td>380V – 11.8A</td> </tr> <tr> <td>415V – 11.7A</td> <td>440V – 10.5A</td> </tr> </table> <p><b>Power Cable</b> Sheath: Chloroprene rubber Standard Length: 8m 380 to 600V supply: 1 x 4 x 2.5mm<sup>2</sup>, O.D. 12.4mm (60245 IEC 66) or 1 x 4 x 3.5mm<sup>2</sup>, O.D. 16.8mm 200 to 240V supply: 1 x 4 x 4mm<sup>2</sup>, O.D. 13.8mm (60245 IEC 66) or 1 x 4 x 3.5mm<sup>2</sup>, O.D. 16.8mm</p> <p><b>Dry Weight</b> (excluding cable) 146kg</p>	50Hz	60Hz	380V – 12.5A	220V – 21.0A	400V – 12.1A	380V – 11.8A	415V – 11.7A	440V – 10.5A	<p><b>Impeller</b> Semi-open impeller made of high-chromium cast iron</p> <p>Solids Passage 50Hz – <math>\phi</math>20mm 60Hz – <math>\phi</math>20mm</p> <p><b>Agitator</b> Ductile cast iron</p> <p><b>Cable Entry with Anti-Wicking Block</b> Watertight cable entry with strain-relief device. The anti-wicking block prevents water incursion due to capillary action should the power cable be damaged or the end submerged.</p> <p><b>Bearing</b> Permanently lubricated, deep-groove, double-shielded C3 ball bearings</p> <p><b>Shaft</b> 420 stainless steel</p> <p><b>Shaft Seal (Mechanical Seal)</b> Furnished with a double-face mechanical seal located in oil chamber. Both upper and lower seal faces always run in a clean environment.</p> <p>Upper Seal Face: SiC + SiC Lower Seal Face: SiC + SiC</p> <p><b>Oil Seal (Lip Seal)</b> Used two as a "Dust Seal", it protects the mechanical seal from abrasive particles.</p> <p><b>OIL LIFTER</b> Equipped in oil chamber. It forcibly supplies lubricating oil to the mechanical seal and continues to supply the oil to the upper seal faces even if lubricant falls below the rated volume.</p> <p>Type of Lubricating Oil &amp; Volume Turbine Oil (ISO VG32), 1200ml</p> <p><b>Motor Protection Device</b> A circle thermal protector built in the motor housing. Directly cuts the motor circuit if excessive heat builds up or an overcurrent condition occurs in the motor.</p>
50Hz	60Hz								
380V – 12.5A	220V – 21.0A								
400V – 12.1A	380V – 11.8A								
415V – 11.7A	440V – 10.5A								

<p><b>Optional Accessory</b></p> <p><b>Male Threaded Coupling</b></p>	<p><b>Special Specifications</b></p> <p><b>High Temperature Liquids Version (60-80°C)</b></p>
---	---

SPECIFICATIONS	Model	NKZ43.7	NKZ-series
			3.7kW, 3-phase

<p><b>Type of Pump</b> Submersible slurry pump for construction and foundation works, mining, and quarries, etc.</p> <p><b>Water Jacket</b> Equipped with a water jacket, around the motor frame. A portion of the pumped liquid is allowed to flow into the water jacket to cool the motor.</p> <p><b>Type of Fluid</b> Water containing sand, mud, and slurry</p> <p>Temperature: 0 to 40°C</p> <p><b>Discharge Bore &amp; Connection</b> 100mm, Hose Coupling</p> <p><b>Motor Output</b> 3.7kW</p> <p><b>Power Supply</b> Three-phase</p> <p><b>Starting Method</b> Direct on Line (Star-Delta available on special request)</p> <p><b>Motor</b> Continuous-duty rated, dry-type induction motor</p> <p>Insulation Class: F Degree of Protection: IP68</p> <p>No. of Poles &amp; Speed (Synchronous Speed) 4-pole, 1500/1800min<sup>-1</sup> (50/60Hz)</p> <p>Power Supply Voltages &amp; Rated Currents</p> <table border="0"> <tr> <td>50Hz</td> <td>60Hz</td> </tr> <tr> <td>380V – 8.8A</td> <td>220V – 15.4A</td> </tr> <tr> <td>400V – 8.6A</td> <td>380V – 8.7A</td> </tr> <tr> <td>415V – 8.4A</td> <td>440V – 7.6A</td> </tr> </table> <p><b>Power Cable</b> Sheath: Chloroprene rubber Standard Length: 8m 380 to 600V supply: 1 x 4 x 1.5mm<sup>2</sup>, O.D. 11.3mm (60245 IEC 66) or 1 x 4 x 2.0mm<sup>2</sup>, O.D. 14.4mm 200 to 240V supply: 1 x 4 x 2.5mm<sup>2</sup>, O.D. 12.4mm (60245 IEC 66) or 1 x 4 x 2.0mm<sup>2</sup>, O.D. 14.4mm</p> <p><b>Dry Weight (excluding cable)</b> 104kg</p>	50Hz	60Hz	380V – 8.8A	220V – 15.4A	400V – 8.6A	380V – 8.7A	415V – 8.4A	440V – 7.6A	<p><b>Impeller</b> Semi-open impeller made of ductile cast iron</p> <p>Solids Passage 50Hz – <math>\phi</math>30mm 60Hz – <math>\phi</math>30mm</p> <p><b>Agitator</b> Ductile cast iron</p> <p><b>Cable Entry with Anti-Wicking Block</b> Watertight cable entry with strain-relief device. The anti-wicking block prevents water incursion due to capillary action should the power cable be damaged or the end submerged.</p> <p><b>Bearing</b> Permanently lubricated, deep-groove, double-shielded C3 ball bearings</p> <p><b>Shaft</b> 420 stainless steel</p> <p><b>Shaft Seal (Mechanical Seal)</b> Furnished with a double-face mechanical seal located in oil chamber. Both upper and lower seal faces always run in a clean environment.</p> <p>Upper Seal Face: SiC + SiC Lower Seal Face: SiC + SiC</p> <p><b>Oil Seal (Lip Seal)</b> Used as a “Dust Seal”, it protects the mechanical seal from abrasive particles.</p> <p><b>OIL LIFTER</b> Equipped in oil chamber. It forcibly supplies lubricating oil to the mechanical seal and continues to supply the oil to the upper seal faces even if lubricant falls below the rated volume.</p> <p>Type of Lubricating Oil &amp; Volume Turbine Oil (ISO VG32), 700ml</p> <p><b>Motor Protection Device</b> A circle thermal protector built in the motor housing. Directly cuts the motor circuit if excessive heat builds up or an overcurrent condition occurs in the motor.</p>
50Hz	60Hz								
380V – 8.8A	220V – 15.4A								
400V – 8.6A	380V – 8.7A								
415V – 8.4A	440V – 7.6A								

<p><b>Optional Accessory</b></p> <p><b>Male Threaded Coupling</b></p>	<p><b>Special Specifications</b></p> <p><b>High Temperature Liquids Version (60-80°C)</b></p>
---	---

SPECIFICATIONS	Model	NKZ45.5	
		NKZ-series 5.5kW, 3-phase	
<p><b>Type of Pump</b> Submersible slurry pump for construction and foundation works, mining, and quarries, etc.</p> <p><b>Water Jacket</b> Equipped with a water jacket, around the motor frame. A portion of the pumped liquid is allowed to flow into the water jacket to cool the motor.</p> <p><b>Type of Fluid</b> Water containing sand, mud, and slurry  Temperature: 0 to 40°C</p> <p><b>Discharge Bore &amp; Connection</b> 100mm, Hose Coupling</p> <p><b>Motor Output</b> 5.5kW</p> <p><b>Power Supply</b> Three-phase</p> <p><b>Starting Method</b> Direct on Line (Star-Delta available on special request)</p> <p><b>Motor</b> Continuous-duty rated, dry-type induction motor  Insulation Class: F Degree of Protection: IP68  No. of Poles &amp; Speed (Synchronous Speed) 4-pole, 1500/1800min<sup>-1</sup> (50/60Hz)  Power Supply Voltages &amp; Rated Currents 50Hz                      60Hz 380V – 12.5A          220V – 21.0A 400V – 12.1A          380V – 11.8A 415V – 11.7A          440V – 10.5A</p> <p><b>Power Cable</b> Sheath: Chloroprene rubber Standard Length: 8m 380 to 600V supply: 1 x 4 x 2.5mm<sup>2</sup>, O.D. 12.4mm (60245 IEC 66) or 1 x 4 x 3.5mm<sup>2</sup>, O.D. 16.8mm 200 to 240V supply: 1 x 4 x 4mm<sup>2</sup>, O.D. 13.8mm (60245 IEC 66) or 1 x 4 x 3.5mm<sup>2</sup>, O.D. 16.8mm</p> <p><b>Dry Weight</b> (excluding cable) 129kg</p>		<p><b>Impeller</b> Semi-open impeller made of ductile cast iron  Solids Passage 50Hz – <math>\phi</math>30mm 60Hz – <math>\phi</math>30mm</p> <p><b>Agitator</b> Ductile cast iron</p> <p><b>Cable Entry with Anti-Wicking Block</b> Watertight cable entry with strain-relief device. The anti-wicking block prevents water incursion due to capillary action should the power cable be damaged or the end submerged.</p> <p><b>Bearing</b> Permanently lubricated, deep-groove, double-shielded C3 ball bearings</p> <p><b>Shaft</b> 420 stainless steel</p> <p><b>Shaft Seal (Mechanical Seal)</b> Furnished with a double-face mechanical seal located in oil chamber. Both upper and lower seal faces always run in a clean environment.  Upper Seal Face: SiC + SiC Lower Seal Face: SiC + SiC</p> <p><b>Oil Seal (Lip Seal)</b> Used as a “Dust Seal”, it protects the mechanical seal from abrasive particles.</p> <p><b>OIL LIFTER</b> Equipped in oil chamber. It forcibly supplies lubricating oil to the mechanical seal and continues to supply the oil to the upper seal faces even if lubricant falls below the rated volume.  Type of Lubricating Oil &amp; Volume Turbine Oil (ISO VG32), 1100ml</p> <p><b>Motor Protection Device</b> A circle thermal protector built in the motor housing. Directly cuts the motor circuit if excessive heat builds up or an overcurrent condition occurs in the motor.</p>	
<p><b>Optional Accessory</b> Male Threaded Coupling</p>		<p><b>Special Specifications</b> High Temperature Liquids Version (60-80°C)</p>	

SPECIFICATIONS	Model	NKZ411	
		NKZ-series 11kW, 3-phase	
<p><b>Type of Pump</b> Submersible slurry pump for construction and foundation works, mining, and quarries, etc.</p> <p><b>Water Jacket</b> Equipped with a water jacket, around the motor frame. A portion of the pumped liquid is allowed to flow into the water jacket to cool the motor.</p> <p><b>Type of Fluid</b> Water containing sand, mud, and slurry  Temperature: 0 to 40°C</p> <p><b>Discharge Bore &amp; Connection</b> 100mm, Hose Coupling</p> <p><b>Motor Output</b> 11kW</p> <p><b>Power Supply</b> Three-phase</p> <p><b>Starting Method</b> Direct on Line (Star-Delta available on special request)</p> <p><b>Motor</b> Continuous-duty rated, dry-type induction motor  Insulation Class: F Degree of Protection: IP68  No. of Poles &amp; Speed (Synchronous Speed) 4-pole, 1500/1800min<sup>-1</sup> (50/60Hz)  Power Supply Voltages &amp; Rated Currents 50Hz                      60Hz 380V – 23.0A          220V – 40.5A 400V – 22.5A          380V – 22.5A 415V – 22.5A          440V – 20.0A</p> <p><b>Power Cable</b> Sheath: Chloroprene rubber Standard Length: 8m 380 to 600V supply: 1 x 4 x 4mm<sup>2</sup>, O.D. 13.8mm (60245 IEC 66) or 1 x 4 x 5.5mm<sup>2</sup>, O.D. 19.8mm 200 to 240V supply: 1 x 4 x 6mm<sup>2</sup>, O.D. 19.0mm (60245 IEC 66) or 1 x 4 x 8mm<sup>2</sup>, O.D. 21.7mm</p> <p><b>Dry Weight (excluding cable)</b> 217kg</p>	<p><b>Impeller</b> Semi-open impeller made of high-chromium cast iron  Solids Passage 50Hz – <math>\phi</math>20mm 60Hz – <math>\phi</math>20mm</p> <p><b>Agitator</b> Ductile cast iron</p> <p><b>Cable Entry with Anti-Wicking Block</b> Watertight cable entry with strain-relief device. The anti-wicking block prevents water incursion due to capillary action should the power cable be damaged or the end submerged.</p> <p><b>Bearing</b> Permanently lubricated, deep-groove, double-shielded C3 ball bearings</p> <p><b>Shaft</b> 420 stainless steel</p> <p><b>Shaft Seal (Mechanical Seal)</b> Furnished with a double-face mechanical seal located in oil chamber. Both upper and lower seal faces always run in a clean environment.  Upper Seal Face: SiC + SiC Lower Seal Face: SiC + SiC</p> <p><b>Oil Seal (Lip Seal)</b> Used two as a "Dust Seal", it protects the mechanical seal from abrasive particles.</p> <p><b>OIL LIFTER</b> Equipped in oil chamber. It forcibly supplies lubricating oil to the mechanical seal and continues to supply the oil to the upper seal faces even if lubricant falls below the rated volume.  Type of Lubricating Oil &amp; Volume Turbine Oil (ISO VG32), 2500ml</p> <p><b>Motor Protection Device</b> A circle thermal protector built in the motor housing. Directly cuts the motor circuit if excessive heat builds up or an overcurrent condition occurs in the motor.</p>		
<p><b>Optional Accessory</b> Male Threaded Coupling</p>	<p><b>Special Specifications</b> High Temperature Liquids Version (60-80°C)</p>		

SPECIFICATIONS	Model	NKZ611	
		NKZ-series 11kW, 3-phase	
<p><b>Type of Pump</b> Submersible slurry pump for construction and foundation works, mining, and quarries, etc.</p> <p><b>Water Jacket</b> Equipped with a water jacket, around the motor frame. A portion of the pumped liquid is allowed to flow into the water jacket to cool the motor.</p> <p><b>Type of Fluid</b> Water containing sand, mud, and slurry  Temperature: 0 to 40°C</p> <p><b>Discharge Bore &amp; Connection</b> 150mm, Hose Coupling</p> <p><b>Motor Output</b> 11kW</p> <p><b>Power Supply</b> Three-phase</p> <p><b>Starting Method</b> Direct on Line (Star-Delta available on special request)</p> <p><b>Motor</b> Continuous-duty rated, dry-type induction motor  Insulation Class: F Degree of Protection: IP68  No. of Poles &amp; Speed (Synchronous Speed) 4-pole, 1500/1800min<sup>-1</sup> (50/60Hz)  Power Supply Voltages &amp; Rated Currents 50Hz                      60Hz 380V – 23.0A          220V – 40.5A 400V – 22.5A          380V – 22.5A 415V – 22.5A          440V – 20.0A</p> <p><b>Power Cable</b> Sheath: Chloroprene rubber Standard Length: 8m 380 to 600V supply: 1 x 4 x 4mm<sup>2</sup>, O.D. 13.8mm (60245 IEC 66) or 1 x 4 x 5.5mm<sup>2</sup>, O.D. 19.8mm 200 to 240V supply: 1 x 4 x 6mm<sup>2</sup>, O.D. 19.0mm (60245 IEC 66) or 1 x 4 x 8mm<sup>2</sup>, O.D. 21.7mm</p> <p><b>Dry Weight (excluding cable)</b> 210kg</p>	<p><b>Impeller</b> Semi-open impeller made of ductile cast iron  Solids Passage 50Hz – <math>\phi</math>30mm 60Hz – <math>\phi</math>30mm</p> <p><b>Agitator</b> Ductile cast iron</p> <p><b>Cable Entry with Anti-Wicking Block</b> Watertight cable entry with strain-relief device. The anti-wicking block prevents water incursion due to capillary action should the power cable be damaged or the end submerged.</p> <p><b>Bearing</b> Permanently lubricated, deep-groove, double-shielded C3 ball bearings</p> <p><b>Shaft</b> 420 stainless steel</p> <p><b>Shaft Seal (Mechanical Seal)</b> Furnished with a double-face mechanical seal located in oil chamber. Both upper and lower seal faces always run in a clean environment.  Upper Seal Face: SiC + SiC Lower Seal Face: SiC + SiC</p> <p><b>Oil Seal (Lip Seal)</b> Used as a “Dust Seal”, it protects the mechanical seal from abrasive particles.</p> <p><b>OIL LIFTER</b> Equipped in oil chamber. It forcibly supplies lubricating oil to the mechanical seal and continues to supply the oil to the upper seal faces even if lubricant falls below the rated volume.  Type of Lubricating Oil &amp; Volume Turbine Oil (ISO VG32), 2500ml</p> <p><b>Motor Protection Device</b> A circle thermal protector built in the motor housing. Directly cuts the motor circuit if excessive heat builds up or an overcurrent condition occurs in the motor.</p>		
<p><b>Optional Accessory</b> <b>Male Threaded Coupling</b></p>		<p><b>Special Specifications</b> <b>High Temperature Liquids Version (60-80°C)</b></p>	



**DIMENSIONS**

Model

**NKZ32.2 to NKZ611**

**NKZ-series**

**80 - 150mm**

C. W. L. : Continuous Running Water Level

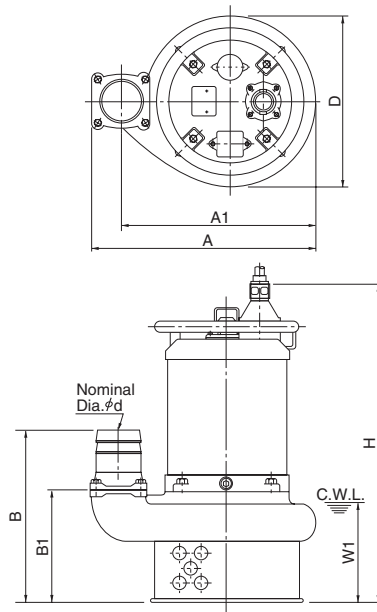

Unit: mm

Model	d	A	A1	B	B1	D	H	W1
NKZ32.2	80	466	404	372	249	368	719	225
NKZ33.7	80	466	404	372	249	368	719	225
NKZ35.5	80	491	430	386	263	400	798	220
NKZ43.7	100	466	404	387	249	368	719	225
NKZ45.5	100	482	420	382	244	382	759	220
NKZ411	100	546	485	421	283	413	885	240
NKZ611	150	618	519	458	265	449	842	240