

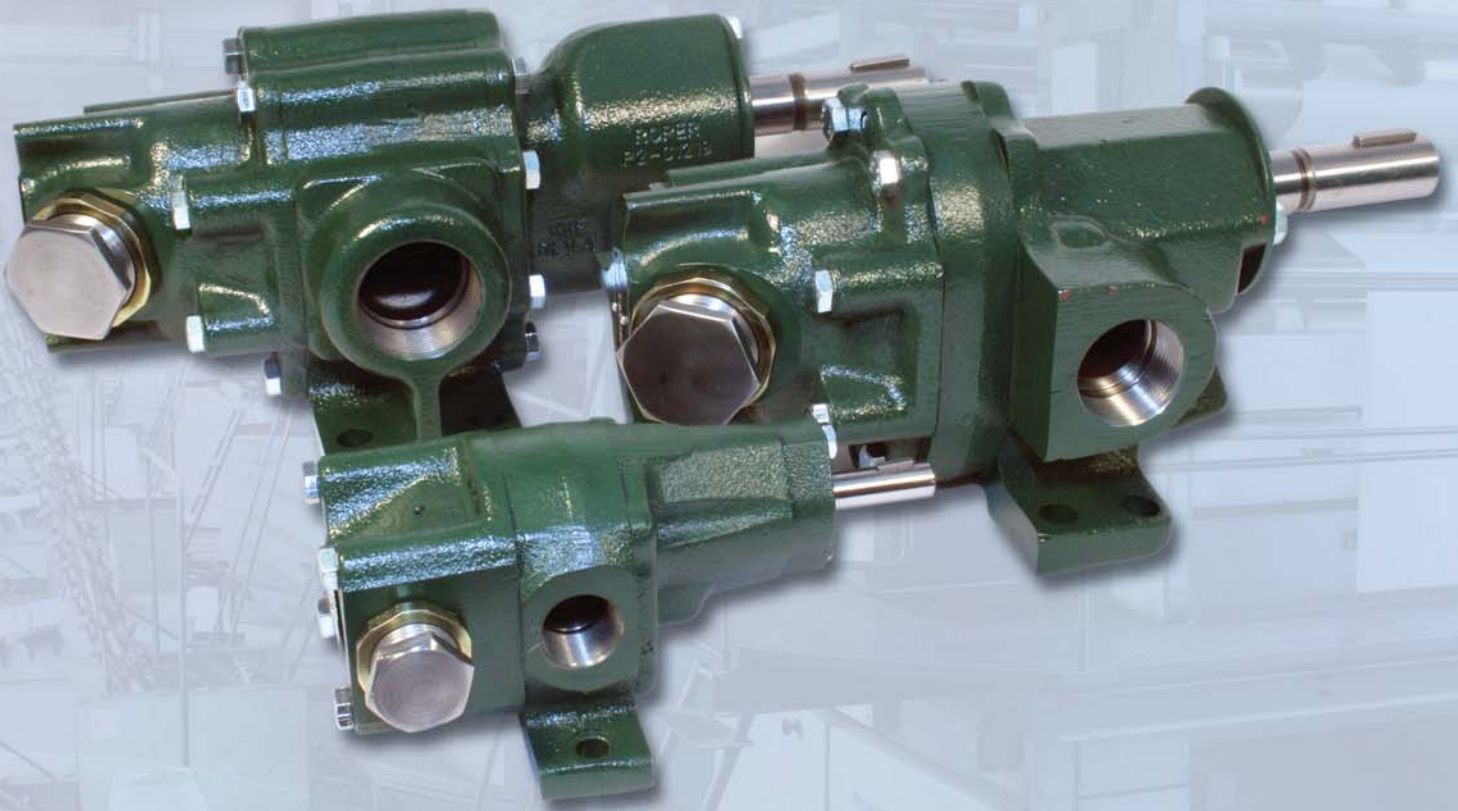













THE LEADING FORCE behind liquids™ since 1857

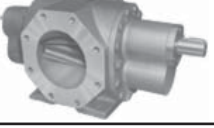

A Series General Purpose Pumps

General Purpose Pumps for Pressure Lubrication,
Hydraulic Service, Fuel Supply and General Transfer

The Roper Pump Family of Gear Pumps

		Typical Applications	Primary Features
	3600	<ul style="list-style-type: none"> Mix, circulate, and transfer viscous liquids Gasoline, asphalt, molasses Ink, roofing compounds, oils 	<ul style="list-style-type: none"> Precise tolerances for maximum efficiency Direct drive or built-on gear reducers Bi-directional rotation* Configurations available for close coupled drive and close coupled hydraulic drive
	Z	<ul style="list-style-type: none"> Industrial applications requiring a special mechanical seal 	<ul style="list-style-type: none"> ANSI Flanges Many parts interchangeable with 3600 Series Direct drive or built-on gear reducers Bi-directional rotation* Configurations available for close coupled drive and close coupled hydraulic drive
	3800	<ul style="list-style-type: none"> Oilfields including light & heavy crude oil Kerosene mixtures, condensates and hot oils 	<ul style="list-style-type: none"> Sealed ball bearings Quadruple grease purged lip seals Helical gears for quiet operation Bi-directional rotation*
	Bulk	<ul style="list-style-type: none"> Fuels, solvents, petrochemicals Residual fuel oils, molasses, resins Tankers, barges, process plants, refineries 	<ul style="list-style-type: none"> Large ports (6" and 8" available) allow more efficient transfer of fluids Thru port design allows for lower inlet and outlet losses
	5600	<ul style="list-style-type: none"> Hydroseeding Grouting, seal coating, oil and sand Wastewater, waste oil, sludge, slurries Brine, paper pulp, fertilizer feeds 	<ul style="list-style-type: none"> Rubber covered gears Bi-directional rotation Abrasive applications; up to pea size particles
	A	<ul style="list-style-type: none"> Pressure lubrication Hydraulic service General transfer applications 	<ul style="list-style-type: none"> Operates at motor speeds Bi-directional rotation* Close coupled capability
	2835	<ul style="list-style-type: none"> Roofing Compounds Molasses Feed Supplements 	<ul style="list-style-type: none"> Operates at standard motor speeds Large ports allow easier fluid entry Built-in relief valve
	V	<ul style="list-style-type: none"> Hazardous liquid transfer "Zero leakage" applications due to environmental concerns Chemical and petroleum applications 	<ul style="list-style-type: none"> Mag-drive, sealless design eliminates seal repair costs and down time C-face mount eliminates misalignment Bi-directional rotation and self-priming
	F	<ul style="list-style-type: none"> Hydraulic power for lifts, machine actuation, fuel burners, and blenders General transfer of oil and petroleum fluids 	<ul style="list-style-type: none"> 2 inlet ports, 2 outlet ports allows multiple piping arrangements (except F150 - F300) High Pressure Range Maintain pump without pipe removal
	ROC	<ul style="list-style-type: none"> Chemical processing Pharmaceutical industry Injection or transfer of acids & solvents 	<ul style="list-style-type: none"> Stainless steel construction Bi-directional rotation* Mag-drive, sealless option (X5-03 only)
	9622	<ul style="list-style-type: none"> Chemical and transport applications Corrosive liquid transfer 	<ul style="list-style-type: none"> 316SS Housing 17-4 PH SST Gears / Shafts Built-in Relief Valve
	PC	<ul style="list-style-type: none"> Viscous, abrasive and solids-containing liquids Transfer of wastewater sludge, polymers, grouts, paints and adhesives 	<ul style="list-style-type: none"> Pulsation free pumping High suction lift capabilities Ideal for shear sensitive liquids

*Pump reconfiguration may be required.

A Series General Purpose Pumps

General Purpose Pumps for Pressure Lubrication,
Hydraulic Service, Fuel Supply and General Transfer

Up to 59 GPM • Up to 300 PSI

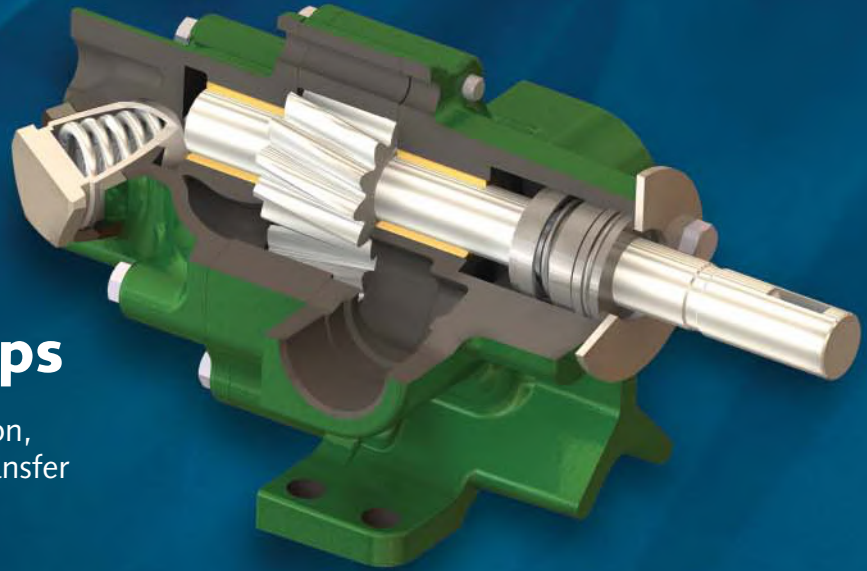

Roper A Series pumps are adaptable to a wide range of applications pumping clean fluids, such as pressure lubrication, hydraulic service, fuel supply or general liquid transfer.

These pumps are designed to operate at standard motor speeds, with provisions for flange or foot mounting. The internal bearings are lubricated by the fluid being pumped. With only two moving parts, the pumps run quietly.

They are manufactured and assembled with close tolerances, and regularly tested to insure dependable performance. Factory assembled for clockwise rotation (facing the pump drive shaft end), most may be reassembled for operation with equal efficiency in a counter-clockwise rotation.

MATERIALS OF CONSTRUCTION

Standard Fitted

Housing.....	Cast Iron
Gears.....	Ductile Iron* Hardened Steel**
Bearings.....	Bronze
Idler Shafts	Ductile Iron* Steel**
Drive Shafts.....	Hardened Steel

Optional Materials

Housing.....	Ductile Iron***
Bearings.....	Iron, Carbon

*06 and larger sizes. **03 and smaller sizes.

*** In 005, 01 and 02 sizes

FEATURES

- Designed to operate at standard motor speeds
- Bi-directional rotation

Quiet-Running Helical Gears

Accurate machining insures:

- proper meshing
- reduced friction and vibration
- quiet, efficient operation
- long life

Long-Lasting Bearing Surfaces

- Bearings are special wear-resistant, high-lead bronze. (Iron and carbon bearings are available.)
- Four heavy duty sleeve bearings give positive support to pumping gears and insure long, efficient service.

Precise, Rugged, Maintenance-Friendly Design

- All castings are cast iron.
- Precise manufacturing tolerances provide minimum clearances for maximum pumping efficiency.
- Large, hardened steel dowel pins insure positive alignment between the faceplate, case, and backplate.

THE LEADING FORCE behind liquids™ since 1857

Capacities & Nomenclature

A SERIES NOMENCLATURE

Model	1 - Foot Mounted	25 - Baseplate Mounted
	2 - Foot Mounted with Relief Valve	26 - Baseplate Mounted with Relief Valve
	17 - Flange Mounted	33 - Close Coupled
	18 - Flange Mounted with Relief Valve	34 - Close Coupled with Relief Valve
Seal Option	AL - Lip Seal	
	AM - Mechanical Seal	
	AP - Packed Box	
	AE - Mechanical Seal (AE Series Only)	
Size* [AL, AM, AP]	005 - 0.05 Gal/100 Rev [0.19 L/100 Rev]	12 - 1.3 Gal/100 Rev [4.92 L/100 Rev]
	01 - 0.1 Gal/100 Rev [0.38 L/100 Rev]	16 - 1.7 Gal/100 Rev [6.44 L/100 Rev]
	02 - 0.2 Gal/100 Rev [0.76 L/100 Rev]	21 - 2.2 Gal/100 Rev [8.33 L/100 Rev]
	03 - 0.3 Gal/100 Rev [1.14 L/100 Rev]	27 - 2.7 Gal/100 Rev [10.22 L/100 Rev]
	06 - 0.6 Gal/100 Rev [2.27 L/100 Rev]	32 - 3.3 Gal/100 Rev [12.49 L/100 Rev]
	08 - 0.9 Gal/100 Rev [3.41 L/100 Rev]	40 - 4.2 Gal/100 Rev [15.90 L/100 Rev]
Size [AE Series]	19 - 1.9 Gal/100 Rev [7.19 L/100 Rev]	54 - 5.4 Gal/100 Rev [20.44 L/100 Rev]
	29 - 2.9 Gal/100 Rev [10.98 L/100 Rev]	75 - 7.5 Gal/100 Rev [28.39 L/100 Rev]

*Size: approximate theoretical flow rate [not including slip]

EXAMPLE: 17AM32	17 Model	AM Seal Option	32 Size	Type 1 Internal Construction
EXAMPLE: 2AE54	2 Model	AE Seal Option	54 Size	Type 1 Internal Construction

SIZE 005 THROUGH 02

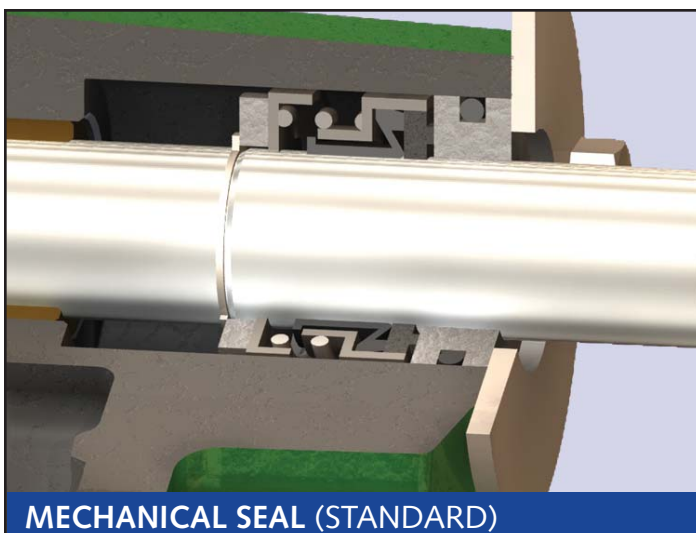
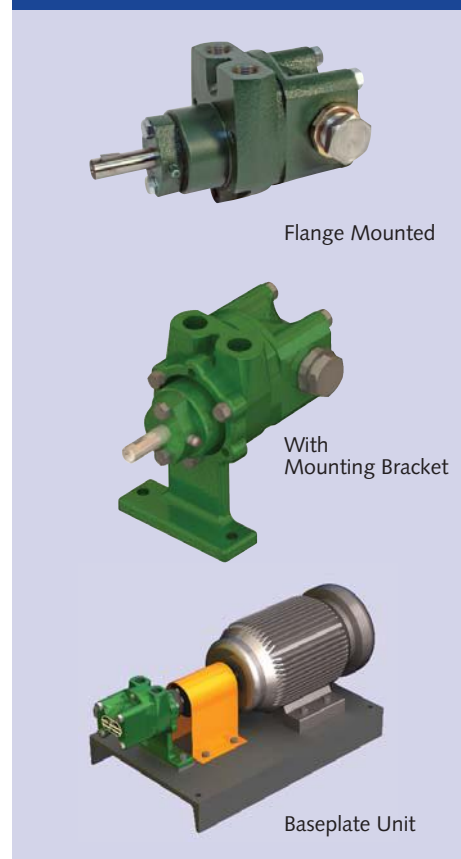

Mechanical seals are for those applications where product leakage is unacceptable. The mechanical seal uses less power than the packed box and, under proper conditions, has a longer service life. It does not require adjustment. Our standard mechanical seal is an elastomeric bellows type seal, with a temperature limit of 212°F (100°C). Special fitting is available for higher temperature applications.

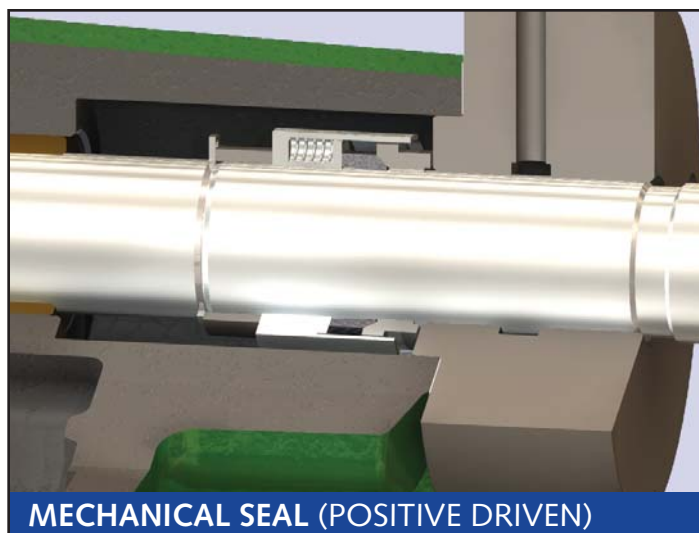

These are positive driven seals with a PTFE wedge, for use where corrosive and/or viscous liquids are being processed. Wedge construction of the secondary sealing element virtually eliminates leakage. These seals have a temperature limit of 450°F (232°C). Special fitting is available for higher temperature applications.

Pump Seals

SIZE 03



Flange Mounted



Foot Mounted

SIZE 06 THROUGH 40



Foot Mounted

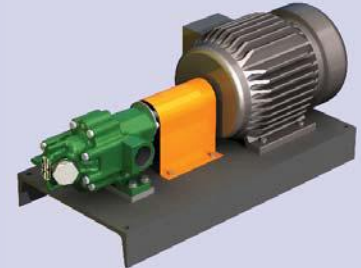

Baseplate Mounted

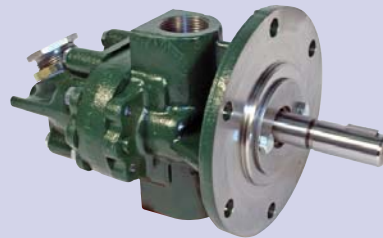

Flange Mounted



Close Coupled to NEMA "C" Motor

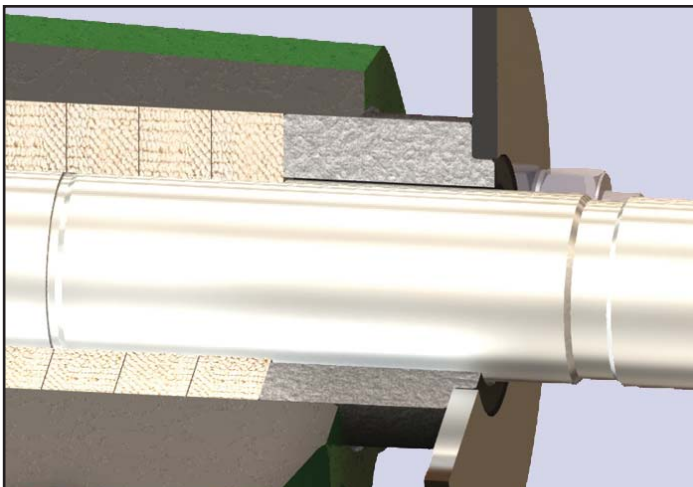

PACKED BOX

The packed box seal is suited for general purpose applications. The standard packing has a temperature limit of 250°F (121°C), with special fitting available for higher temperature applications. The gland should be adjusted to allow slight seepage.

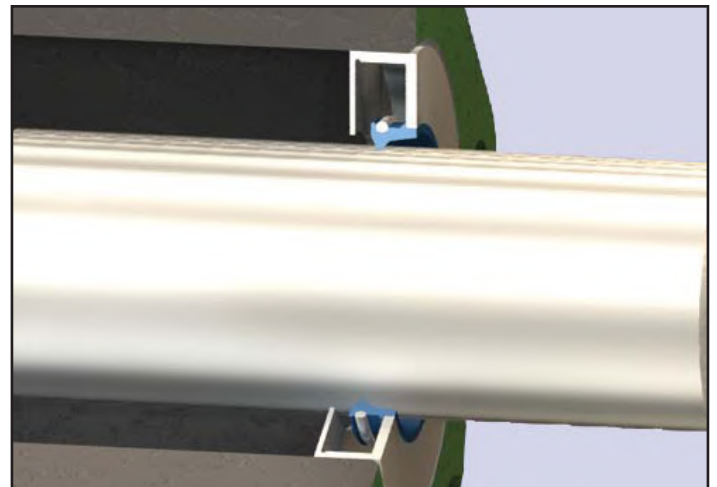

LIP SEAL

The lip seal is suitable for low pressure sealing of lubricating fluids. The standard seal has a temperature limit of 212°F (100°C). Special fitting is available for higher temperature applications. Available in CW rotation only and 100 psi maximum discharge.

A Series Performance Charts

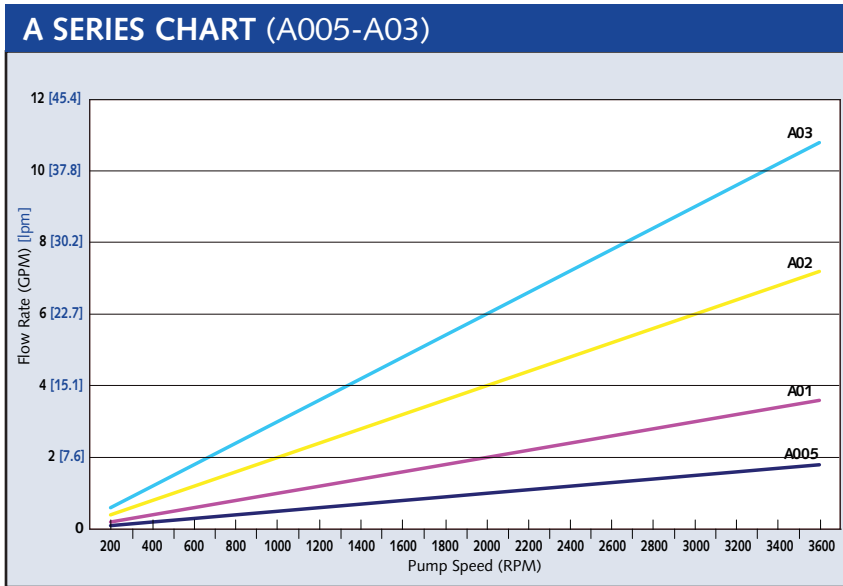

Performance figures show maximum horsepower requirements for minimum rated gallons per minute at the various speeds, viscosities and pressures. The charts are intended as a guide for conditions at the pump. In determining the proper conditions of operation for the pump, many factors must be considered including inlet conditions, liquid characteristics, and temperature.

If there is any question concerning these charts or the recommended operating conditions, please consult your Roper distributor, district representative, or the home office.

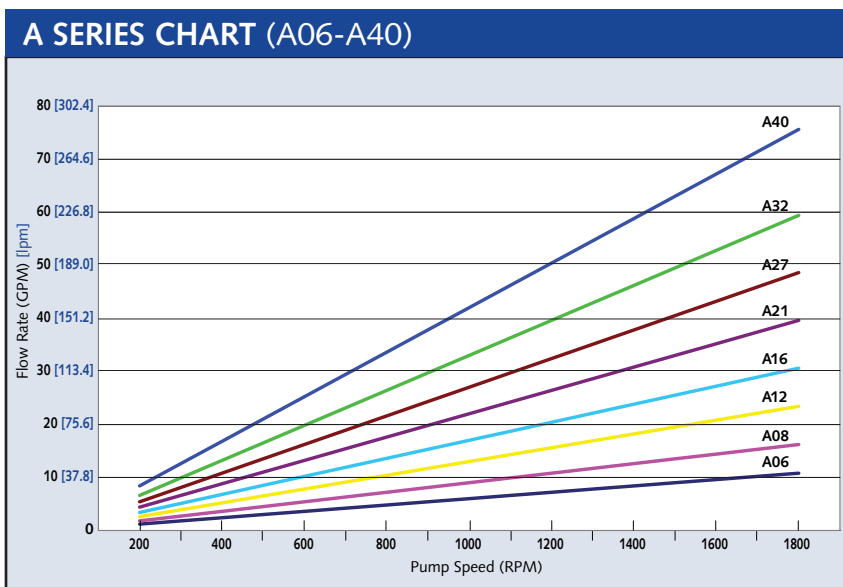

SIZE	RPM		3600 RPM				
	PSI [bar]	SSU	30	100	1000	5000	30
005	50	GPM [l/min]	1.62 [6.1]	1.78 [6.7]	1.83 [6.9]	1.83 [6.9]	0.7 [2.6]
	3.5	HP [kW]	0.41 [0.3]	0.32 [0.2]	0.53 [0.4]	0.84 [0.6]	0.17 [0.1]
	150	GPM [l/min]	1.3 [4.9]	1.71 [6.5]	1.83 [6.9]	1.83 [6.9]	0.38 [1.4]
	10.3	HP [kW]	0.8 [0.6]	0.47 [0.4]	0.64 [0.5]	0.95 [0.7]	0.33 [0.2]
01	50	GPM [l/min]	3.4 [12.9]	3.55 [13.4]	3.59 [13.6]	3.59 [13.6]	1.6 [6.1]
	3.5	HP [kW]	0.36 [0.3]	0.4 [0.3]	0.7 [0.5]	1.1 [0.8]	0.14 [0.1]
	150	GPM [l/min]	2.99 [11.3]	3.44 [13.0]	3.59 [13.6]	3.59 [13.6]	1.19 [4.5]
	10.3	HP [kW]	0.8 [0.6]	0.68 [0.5]	0.91 [0.7]	1.28 [1.0]	0.32 [0.2]
02	50	GPM [l/min]	7.01 [26.5]	7.35 [27.8]	7.53 [28.5]	7.55 [28.6]	3.23 [12.2]
	3.5	HP [kW]	0.48 [0.4]	0.52 [0.4]	0.82 [0.6]	1.19 [0.9]	0.2 [0.1]
	150	GPM [l/min]	6.26 [23.7]	7.09 [26.8]	7.48 [28.3]	7.54 [28.5]	2.48 [9.4]
	10.3	HP [kW]	1.15 [0.9]	1.03 [0.8]	1.26 [0.9]	1.63 [1.2]	0.5 [0.4]
03	50	GPM [l/min]	10.42 [39.4]	11.05 [41.8]	11.41 [43.2]	11.49 [43.5]	4.66 [17.6]
	3.5	HP [kW]	0.7 [0.5]	0.68 [0.5]	0.94 [0.7]	1.29 [1.0]	0.34 [0.3]
	150	GPM [l/min]	9.3 [35.2]	10 [37.9]	11.32 [42.9]	11.45 [43.3]	3.66 [13.9]
	10.3	HP [kW]	1.6 [1.2]	1.6 [1.2]	1.61 [1.2]	1.96 [1.5]	0.85 [0.6]
03	50	GPM [l/min]	9.3 [35.2]	10 [37.9]	11.32 [42.9]	11.45 [43.3]	3.66 [13.9]
	3.5	HP [kW]	1.6 [1.2]	1.6 [1.2]	1.61 [1.2]	1.96 [1.5]	0.85 [0.6]
	150	GPM [l/min]	9.3 [35.2]	10 [37.9]	11.32 [42.9]	11.45 [43.3]	3.66 [13.9]
	10.3	HP [kW]	1.6 [1.2]	1.6 [1.2]	1.61 [1.2]	1.96 [1.5]	0.85 [0.6]

SIZE	RPM		1800 RPM			
	PSI [bar]	SSU	30	100	1000	5000
06	50	GPM [l/min]	10.6 [40.1]	10.9 [41.3]	11.2 [42.4]	11.2 [42.4]
	3.5	HP [kW]	0.88 [0.7]	0.88 [0.7]	1.33 [1.0]	2.08 [1.6]
	100	GPM [l/min]	9.8 [37.1]	10.4 [39.4]	11 [41.6]	11.1 [42.0]
	6.9	HP [kW]	1.21 [0.9]	1.21 [0.9]	1.66 [1.2]	2.41 [1.8]
08	50	GPM [l/min]	15.5 [58.7]	15.8 [59.8]	16.1 [60.9]	16.1 [60.9]
	3.5	HP [kW]	1.7 [1.3]	1.7 [1.3]	1.7 [1.3]	2.1 [1.6]
	100	GPM [l/min]	14.6 [55.3]	15.3 [57.9]	15.9 [60.2]	16 [60.6]
	6.9	HP [kW]	2.2 [1.6]	2.2 [1.6]	2.2 [1.6]	2.6 [1.9]
12	50	GPM [l/min]	21.4 [81.0]	22.2 [84.0]	23 [87.1]	23.2 [87.8]
	3.5	HP [kW]	1.7 [1.3]	1.8 [1.3]	2.3 [1.7]	2.7 [2.0]
	100	GPM [l/min]	19.9 [75.3]	21.4 [81.0]	22.7 [85.9]	23 [87.1]
	6.9	HP [kW]	2.3 [1.7]	2.5 [1.9]	3 [2.2]	3.4 [2.5]
16	50	GPM [l/min]	27.8 [105.2]	29.2 [110.5]	30.4 [115.1]	30.8 [116.6]
	3.5	HP [kW]	2.1 [1.6]	2.3 [1.7]	2.6 [1.9]	3.4 [2.5]
	100	GPM [l/min]	25.7 [97.3]	28 [106.0]	30 [113.6]	30.6 [115.8]
	6.9	HP [kW]	3 [2.2]	3.2 [2.4]	3.5 [2.6]	4.3 [3.2]
21	50	GPM [l/min]	34.5 [130.6]	36.6 [138.5]	38.5 [145.7]	39.1 [148.0]
	3.5	HP [kW]	2.7 [2.0]	2.8 [2.1]	3 [2.2]	4.1 [3.1]
	100	GPM [l/min]	31.7 [120.0]	35 [132.5]	37.9 [143.5]	38.8 [146.9]
	6.9	HP [kW]	3.8 [2.8]	3.9 [2.9]	4.1 [3.1]	5.3 [4.0]
27	50	GPM [l/min]	42.6 [161.3]	45.5 [172.2]	48.1 [182.1]	48.8 [184.7]
	3.5	HP [kW]	3.3 [2.5]	3.3 [2.5]	3.5 [2.6]	4.9 [3.7]
	100	GPM [l/min]	39.3 [150.0]	43.4 [164.3]	47.3 [179.0]	48.4 [183.2]
	6.9	HP [kW]	4.7 [3.5]	4.7 [3.5]	4.9 [3.7]	6.3 [4.7]
32	50	GPM [l/min]	50.8 [192.3]	54.3 [205.5]	57.6 [218.0]	58.5 [221.4]
	3.5	HP [kW]	3.9 [2.9]	3.9 [2.9]	4.1 [3.1]	5.7 [4.3]
	100	GPM [l/min]	46.9 [179.0]	51.8 [196.1]	56.7 [214.6]	58.1 [219.9]
	6.9	HP [kW]	5.6 [4.2]	5.8 [4.3]	6.3 [4.7]	7.5 [5.6]
40	50	GPM [l/min]	66.5 [251.7]	70.3 [266.1]	73.7 [279.0]	74.7 [282.8]
	3.5	HP [kW]	4.6 [3.4]	4.8 [3.6]	5.8 [4.3]	6.1 [4.6]
	100	GPM [l/min]	61.3 [230.0]	67.3 [254.8]	72.7 [275.2]	74.1 [280.5]
	6.9	HP [kW]	6.9 [5.1]	6.9 [5.1]	7.9 [5.9]	11.2 [8.4]
40	50	GPM [l/min]	66.5 [251.7]	70.3 [266.1]	73.7 [279.0]	74.7 [282.8]
	3.5	HP [kW]	4.6 [3.4]	4.8 [3.6]	5.8 [4.3]	6.1 [4.6]
	150	GPM [l/min]	64.6 [244.5]	71.9 [272.2]	73.8 [279.4]	73.8 [279.4]
	10.3	HP [kW]	9.1 [6.8]	10.1 [7.5]	13.4 [10.0]	13.4 [10.0]

1800 RPM			1200 RPM				900 RPM				720 RPM			
100	1000	5000	30	100	1000	5000	30	100	1000	5000	30	100	1000	5000
0.87 [3.3] 0.14 [0.1]	0.91 [3.4] 0.21 [0.2]	0.91 [3.4] 0.34 [0.3]	0.39 [1.5] 0.06 [0.0]	0.56 [2.1] 0.06 [0.0]	0.61 [2.3] 0.13 [0.1]	0.61 [2.3] 0.21 [0.2]	0.24 [0.9] 0.05 [0.0]	0.41 [1.6] 0.05 [0.0]	0.45 [1.7] 0.09 [0.1]	0.45 [1.7] 0.15 [0.1]	0.15 [0.6] 0.04 [0.0]	0.32 [1.2] 0.04 [0.0]	0.36 [1.4] 0.06 [0.0]	0.36 [1.4] 0.12 [0.1]
0.79 [3.0] 0.21 [0.2]	0.91 [3.4] 0.26 [0.2]	0.91 [3.4] 0.39 [0.3]		0.48 [1.8] 0.1 [0.1]	0.61 [2.3] 0.15 [0.1]	0.61 [2.3] 0.24 [0.2]		0.33 [1.2] 0.08 [0.1]	0.45 [1.7] 0.11 [0.1]	0.45 [1.7] 0.18 [0.1]		0.24 [0.9] 0.06 [0.0]	0.36 [1.4] 0.09 [0.1]	0.36 [1.4] 0.14 [0.1]
	0.9 [3.4] 0.34 [0.3]	0.91 [3.4] 0.47 [0.4]		0.39 [1.5] 0.15 [0.1]	0.61 [2.3] 0.2 [0.1]	0.61 [2.3] 0.3 [0.2]		0.24 [0.9] 0.12 [0.1]	0.44 [1.7] 0.15 [0.1]	0.45 [1.7] 0.22 [0.2]			0.35 [1.3] 0.12 [0.1]	0.36 [1.4] 0.17 [0.1]
1.75 [6.6] 0.16 [0.1]	1.79 [6.8] 0.26 [0.2]	1.79 [6.8] 0.39 [0.3]	1 [3.8] 0.09 [0.1]	1.15 [4.4] 0.09 [0.1]	1.19 [4.5] 0.15 [0.1]	1.19 [4.5] 0.26 [0.2]	0.7 [2.6] 0.06 [0.0]	0.85 [3.2] 0.06 [0.0]	0.89 [3.4] 0.1 [0.1]	0.89 [3.4] 0.18 [0.1]	0.52 [2.0] 0.05 [0.0]	0.67 [2.5] 0.05 [0.0]	0.71 [2.7] 0.07 [0.1]	0.71 [2.7] 0.13 [0.1]
1.64 [6.2] 0.29 [0.2]	1.79 [6.8] 0.37 [0.3]	1.79 [6.8] 0.5 [0.4]		1.04 [3.9] 0.5 [0.4]	1.19 [4.5] 0.22 [0.2]	1.19 [4.5] 0.33 [0.2]		0.74 [2.8] 0.11 [0.1]	0.89 [3.4] 0.15 [0.1]	0.89 [3.4] 0.23 [0.2]		0.56 [2.1] 0.09 [0.1]	0.71 [2.7] 0.12 [0.1]	0.71 [2.7] 0.17 [0.1]
1.46 [5.5] 0.45 [0.3]	1.78 [6.7] 0.52 [0.4]	1.79 [6.8] 0.65 [0.5]		0.86 [3.3] 0.27 [0.2]	1.18 [4.5] 0.33 [0.2]	1.19 [4.5] 0.44 [0.3]		0.56 [2.1] 0.19 [0.1]	0.88 [3.3] 0.23 [0.2]	0.89 [3.4] 0.31 [0.2]		0.38 [1.4] 0.15 [0.1]	0.7 [2.6] 0.18 [0.1]	0.71 [2.7] 0.24 [0.2]
3.57 [13.5] 0.22 [0.2]	3.75 [14.2] 0.32 [0.2]	3.77 [14.3] 0.45 [0.3]	1.97 [7.5] 0.13 [0.1]	2.31 [8.7] 0.13 [0.1]	2.49 [9.4] 0.19 [0.1]	2.51 [9.5] 0.3 [0.2]	1.34 [5.1] 0.09 [0.1]	1.68 [6.4] 0.09 [0.1]	1.86 [7.0] 0.13 [0.1]	1.88 [7.1] 0.21 [0.2]	0.96 [3.6] 0.07 [0.1]	1.3 [4.9] 0.07 [0.1]	1.48 [5.6] 0.1 [0.1]	1.5 [5.7] 0.15 [0.1]
3.31 [12.5] 0.46 [0.3]	3.7 [14.0] 0.54 [0.4]	3.76 [14.2] 0.67 [0.5]		2.05 [7.8] 0.28 [0.2]	2.44 [9.2] 0.34 [0.3]	2.51 [9.5] 0.45 [0.3]		1.42 [5.4] 0.2 [0.1]	1.81 [6.9] 0.24 [0.2]	1.88 [7.1] 0.32 [0.2]		1.04 [3.9] 0.16 [0.1]	1.44 [5.5] 0.19 [0.1]	1.5 [5.7] 0.24 [0.2]
2.96 [11.2] 0.8 [0.6]	3.64 [13.8] 0.87 [0.6]	3.74 [14.2] 1 [0.7]		1.7 [6.4] 0.5 [0.4]	2.38 [9.0] 0.56 [0.4]	2.5 [9.5] 0.67 [0.5]		1.07 [4.1] 0.37 [0.3]	1.75 [6.6] 0.4 [0.3]	1.87 [7.1] 0.48 [0.4]		1.37 [5.2] 0.32 [0.2]	1.49 [5.6] 0.37 [0.3]	1.49 [5.6] 0.37 [0.3]
5.29 [20.0] 0.33 [0.2]	5.65 [21.4] 0.45 [0.3]	5.73 [21.7] 0.62 [0.5]	2.74 [10.4] 0.2 [0.1]	3.37 [12.8] 0.2 [0.1]	3.73 [14.1] 0.29 [0.2]	3.82 [14.5] 0.46 [0.3]	1.78 [6.7] 0.15 [0.1]	2.41 [9.1] 0.15 [0.1]	2.77 [10.5] 0.21 [0.2]	2.86 [10.8] 0.34 [0.3]	1.2 [4.5] 0.12 [0.1]	1.83 [6.9] 0.12 [0.1]	2.19 [8.3] 0.17 [0.1]	2.28 [8.6] 0.27 [0.2]
4.83 [18.3] 0.68 [0.5]	5.56 [21.0] 0.77 [0.6]	5.69 [21.5] 0.94 [0.7]		2.91 [11.0] 0.41 [0.3]	3.64 [13.8] 0.5 [0.4]	3.8 [14.4] 0.67 [0.5]		1.95 [7.4] 0.31 [0.2]	2.68 [10.1] 0.37 [0.3]	2.84 [10.8] 0.5 [0.4]		1.37 [5.2] 0.25 [0.2]	2.1 [7.9] 0.3 [0.2]	2.26 [8.6] 0.4 [0.3]
3.8 [14.4] 1.3 [1.0]	5.45 [20.6] 1.25 [0.9]	5.65 [21.4] 1.42 [1.1]		2.44 [9.2] 0.74 [0.6]	3.53 [13.4] 0.83 [0.6]	3.78 [14.3] 1 [0.7]		1.48 [5.6] 0.55 [0.4]	2.57 [9.7] 0.6 [0.4]	2.82 [10.7] 0.7 [0.5]		1.99 [7.7] 0.5 [0.4]	2.24 [8.5] 0.6 [0.4]	2.24 [8.5] 0.6 [0.4]

NOTE: Consult your Roper Area Sales Manager for operation in the ranges indicated by the yellow colored areas.

1200 RPM				900 RPM					720 RPM				
30	100	1000	5000	30	100	1000	5000	10000	30	100	1000	5000	10000
6.8 [25.7] 0.48 [0.4]	7.1 [26.9] 0.48 [0.4]	7.4 [28.0] 0.7 [0.5]	7.5 [28.4] 1.04 [0.8]	4.9 [18.5] 0.34 [0.3]	5.2 [19.7] 0.34 [0.3]	5.5 [20.8] 0.49 [0.4]	5.6 [21.2] 0.71 [0.5]	5.6 [21.2] 0.85 [0.6]	3.8 [14.4] 0.25 [0.2]	4.1 [15.5] 0.25 [0.2]	4.4 [16.7] 0.35 [0.3]	4.4 [16.7] 0.48 [0.4]	4.5 [17.0] 0.57 [0.4]
6 [22.7] 0.7 [0.5]	6.7 [25.4] 0.7 [0.5]	7.2 [27.3] 0.92 [0.7]	7.4 [28.0] 1.26 [0.9]	4.1 [15.5] 0.5 [0.4]	4.8 [18.2] 0.5 [0.4]	5.3 [20.1] 0.65 [0.5]	5.5 [20.8] 0.87 [0.6]	5.5 [20.8] 1.01 [0.8]		3.6 [13.6] 0.38 [0.3]	4.2 [15.9] 0.48 [0.4]	4.4 [16.7] 0.61 [0.5]	4.4 [16.7] 0.7 [0.5]
	6 [22.7] 0.92 [0.7]	7 [26.5] 1.14 [0.9]	7.3 [27.6] 1.48 [1.1]		4.1 [15.5] 0.67 [0.5]	5.1 [19.3] 0.82 [0.6]	5.4 [20.4] 1.04 [0.8]	5.4 [20.4] 1.18 [0.9]			4 [15.1] 0.62 [0.5]	4.3 [16.3] 0.75 [0.6]	4.3 [16.3] 0.84 [0.6]
10.1 [38.2] 0.6 [0.4]	10.4 [39.4] 0.6 [0.4]	10.7 [40.5] 0.8 [0.6]	10.7 [40.5] 1.2 [0.9]	7.4 [28.0] 0.4 [0.3]	7.7 [29.1] 0.4 [0.3]	8 [30.3] 0.6 [0.4]	8 [30.3] 0.8 [0.6]	8.1 [30.7] 0.9 [0.7]	5.8 [22.0] 0.3 [0.2]	6.1 [23.1] 0.3 [0.2]	6.3 [23.8] 0.4 [0.3]	6.4 [24.2] 0.6 [0.4]	6.4 [24.2] 0.6 [0.4]
9.2 [34.8] 1 [0.7]	9.9 [37.5] 1 [0.7]	10.5 [39.7] 1.1 [0.8]	10.6 [40.1] 1.5 [1.1]	6.5 [24.6] 0.6 [0.4]	7.2 [27.3] 0.6 [0.4]	7.8 [29.5] 0.8 [0.6]	7.9 [29.9] 1 [0.7]	8 [30.3] 1.1 [0.8]	4.9 [18.5] 0.4 [0.3]	5.6 [21.2] 0.5 [0.4]	6.2 [23.5] 0.6 [0.4]	6.3 [23.8] 0.7 [0.5]	6.4 [24.2] 0.8 [0.6]
8.2 [31.0] 1.3 [1.0]	9.3 [35.2] 1.3 [1.0]	10.3 [39.0] 1.5 [1.1]	10.6 [40.1] 1.8 [1.3]		6.6 [25.0] 0.9 [0.7]	7.6 [28.8] 1 [0.7]	7.9 [29.9] 1.2 [0.9]	7.9 [29.9] 1.8 [1.3]		5 [18.9] 0.7 [0.5]	6 [22.7] 0.8 [0.6]	6.2 [23.5] 0.9 [0.7]	6.3 [23.8] 1 [0.7]
13.6 [51.5] 0.9 [0.7]	14.4 [54.5] 1 [0.7]	15.2 [57.5] 1.2 [0.9]	15.4 [58.3] 1.5 [1.1]	9.7 [36.7] 0.6 [0.4]	10.5 [39.7] 0.6 [0.4]	11.3 [42.8] 0.8 [0.6]	11.5 [43.5] 1 [0.7]	11.6 [43.9] 1.2 [0.9]	7.4 [28.0] 0.4 [0.3]	8.2 [31.0] 0.5 [0.4]	8.9 [33.7] 0.6 [0.4]	9.2 [34.8] 0.8 [0.6]	9.2 [34.8] 0.9 [0.7]
12.1 [45.8] 1.3 [1.0]	13.6 [51.5] 1.4 [1.0]	14.9 [56.4] 1.6 [1.2]	15.2 [57.5] 2 [1.5]		9.7 [36.7] 1 [0.7]	11 [41.6] 1.1 [0.8]	11.3 [42.8] 1.4 [1.0]	11.4 [43.2] 1.5 [1.1]		7.3 [27.6] 0.7 [0.5]	8.6 [32.6] 0.8 [0.6]	9 [34.1] 1 [0.7]	9.1 [34.4] 1.2 [0.9]
	12.7 [48.1] 1.9 [1.4]	14.6 [55.3] 2.1 [1.6]	15.1 [57.2] 2.4 [1.8]		8.8 [33.3] 1.3 [1.0]	10.7 [40.5] 1.4 [1.0]	11.2 [42.4] 1.7 [1.3]	11.3 [42.8] 1.9 [1.4]		6.4 [24.2] 1 [0.7]	8.3 [31.4] 1.1 [0.8]	8.9 [33.7] 1.3 [1.0]	9 [34.1] 1.4 [1.0]
17.4 [65.9] 1.2 [0.9]	18.8 [71.2] 1.3 [1.0]	20.1 [76.1] 1.4 [1.0]	20.4 [77.2] 1.8 [1.3]	12.2 [46.2] 0.8 [0.6]	13.6 [51.5] 0.8 [0.6]	14.9 [56.4] 1 [0.7]	15.2 [57.5] 1.3 [1.0]	15.3 [57.9] 1.5 [1.1]	9.1 [34.4] 0.6 [0.4]	10.5 [39.7] 0.6 [0.4]	11.8 [44.7] 0.7 [0.5]	12.1 [45.8] 1 [0.7]	12.2 [46.2] 1.1 [0.8]
	17.6 [66.6] 1.9 [1.4]	19.6 [74.2] 2 [1.5]	20.2 [76.5] 2.4 [1.8]		12.4 [46.9] 1.3 [1.0]	14.4 [54.5] 1.4 [1.0]	15 [56.8] 1.8 [1.3]	15.2 [57.5] 2 [1.5]		9.3 [35.2] 1 [0.7]	11.3 [42.8] 1.1 [0.8]	11.9 [45.0] 1.3 [1.0]	12.1 [45.8] 1.5 [1.1]
	16.5 [62.5] 2.5 [1.9]	19.2 [72.7] 2.6 [1.9]	20 [75.7] 3 [2.2]		11.3 [42.8] 1.7 [1.3]	14 [53.0] 1.9 [1.4]	14.8 [56.0] 2.2 [1.6]	15 [56.8] 2.4 [1.8]			10.9 [41.3] 1.5 [1.1]	11.7 [44.3] 1.7 [1.3]	11.9 [45.0] 1.9 [1.4]
21.3 [80.6] 1.5 [1.1]	23.4 [88.6] 1.6 [1.2]	25.3 [95.8] 1.7 [1.3]	25.9 [98.0] 2.4 [1.8]	14.7 [55.6] 1.1 [0.8]	16.8 [63.6] 1.1 [0.8]	18.7 [70.8] 1.2 [0.9]	19.3 [73.1] 1.7 [1.3]	19.4 [73.4] 2 [1.5]		12.8 [48.5] 0.8 [0.6]	14.8 [56.0] 0.9 [0.7]	15.3 [57.9] 1.3 [1.0]	15.6 [59.1] 1.5 [1.1]
	21.8 [82.5] 2.4 [1.8]	24.7 [93.5] 2.5 [1.9]	25.6 [96.9] 3.2 [2.4]		15.2 [57.5] 1.7 [1.3]	18.1 [68.5] 1.8 [1.3]	19 [71.9] 2.3 [1.7]	19.2 [72.7] 2.5 [1.9]		11.2 [42.4] 1.3 [1.0]	14.2 [53.8] 1.4 [1.0]	15 [56.8] 1.7 [1.3]	15.2 [57.5] 1.9 [1.4]
	20.2 [76.5] 3.1 [2.3]	24.2 [91.6] 3.3 [2.5]	25.3 [95.8] 4 [3.0]			17.6 [66.6] 2.4 [1.8]	18.7 [70.8] 2.9 [2.2]	19 [71.9] 3.1 [2.3]			13.6 [51.5] 1.9 [1.4]	14.7 [55.6] 2.2 [1.6]	15 [56.8] 2.4 [1.8]
26.1 [98.8] 1.9 [1.4]	29 [109.8] 2 [1.5]	31.6 [119.6] 2.1 [1.6]	32.3 [122.3] 2.9 [2.2]	17.9 [67.8] 1.4 [1.0]	20.8 [78.7] 1.4 [1.0]	23.3 [88.2] 1.6 [1.2]	24 [90.8] 2.1 [1.6]	24.2 [91.6] 2.5 [1.9]		15.8 [59.8] 1 [0.7]	18.4 [69.7] 1.2 [0.9]	19.1 [72.3] 1.6 [1.2]	19.3 [73.1] 1.8 [1.3]
	26.9 [101.8] 2.9 [2.2]	30.8 [116.6] 3.1 [2.3]	31.9 [120.8] 3.9 [2.9]		18.7 [70.8] 2.1 [1.6]	22.6 [85.6] 2.3 [1.7]	23.7 [89.7] 2.8 [2.1]	24 [90.8] 3.2 [2.4]			17.6 [66.6] 1.8 [1.3]	18.7 [70.8] 2.2 [1.6]	19 [71.9] 2.4 [1.8]
		30.1 [113.9] 4 [3.0]	31.6 [119.6] 4.8 [3.6]			21.9 [82.9] 3 [2.2]	23.3 [88.2] 3.5 [2.6]	23.7 [89.7] 3.9 [2.9]			16.9 [64.0] 2.3 [1.7]	18.4 [69.7] 2.7 [2.0]	18.8 [71.2] 3.1 [2.3]
31 [117.3] 2.3 [1.7]	34.5 [130.6] 2.3 [1.7]	37.8 [143.1] 2.5 [1.9]	38.7 [146.5] 3.4 [2.5]		24.6 [93.1] 1.7 [1.3]	27.9 [105.6] 1.8 [1.3]	28.8 [109.0] 2.5 [1.9]	29.1 [110.2] 2.9 [2.2]		18.7 [70.8] 1.3 [1.0]	22 [83.3] 1.4 [1.0]	22.9 [86.7] 1.9 [1.4]	23.1 [87.4] 2.2 [1.6]
	32 [121.1] 3.5 [2.6]	36.9 [139.7] 3.7 [2.8]	38.3 [145.0] 4.6 [3.4]		22.1 [83.7] 2.5 [1.9]	27 [102.2] 3.3 [2.5]	28.4 [107.5] 3.3 [2.5]	28.7 [108.6] 3.7 [2.8]			21.1 [79.9] 2.1 [1.6]	22.4 [84.8] 2.6 [1.9]	22.8 [86.3] 2.9 [2.2]
		36 [136.3] 4.85 [3.6]	37.9 [143.5] 5.8 [4.3]			26.1 [98.8] 3.5 [2.6]	28 [106.0] 4.2 [3.1]	28.4 [107.5] 4.6 [3.4]			20.2 [76.5] 2.8 [2.1]	22 [83.3] 3.3 [2.5]	22.5 [85.2] 3.6 [2.7]
41.3 [156.3] 2.8 [2.1]	45.1 [170.7] 3 [2.2]	48.5 [183.6] 3.3 [2.5]	49.5 [187.4] 4.9 [3.7]		32.5 [123.0] 2.1 [1.6]	35.9 [135.9] 2.3 [1.7]	36.9 [139.7] 3.2 [2.4]	37.2 [140.8] 4 [3.0]		24.94 [94.4] 1.5 [1.1]	28.3 [107.1] 1.6 [1.2]	29.3 [110.9] 2.3 [1.7]	29.6 [112.0] 2.8 [2.1]
	42.1 [159.4] 4.4 [3.3]	47.5 [179.8] 4.7 [3.5]	48.9 [185.1] 6.3 [4.7]		29.5 [111.7] 3.2 [2.4]	34.9 [132.1] 3.4 [2.5]	36.3 [137.4] 4.3 [3.2]	36.8 [139.3] 5.1 [3.8]			27.3 [103.3] 2.6 [1.9]	28.7 [108.6] 3.3 [2.5]	29.2 [110.5] 3.8 [2.8]
		46.7 [176.8] 6.3 [4.7]	48.6 [184.0] 7.9 [5.9]			34.1 [129.1] 4.4 [3.3]	36 [136.3] 5.3 [4.0]	36.5 [138.2] 6.1 [4.5]			26.5 [100.3] 3.5 [2.6]	28.4 [107.5] 4.2 [3.1]	28.9 [109.4] 4.7 [3.5]

NOTE: An outboard ball bearing is recommended for viscosities below 40 ssu.

A Series Dimensions

SIZE 005 THROUGH 02 (flange mounted)

PUMP	C	R	PUMP	C	R
17A-005	5-9/16 [141]		18A-01		6-15/16 [176]
18A-005		6-3/4 [171]	17A-02	6-3/16 [157]	
17A-01	5-13/16 [148]		18A-02		7-3/8 [187]

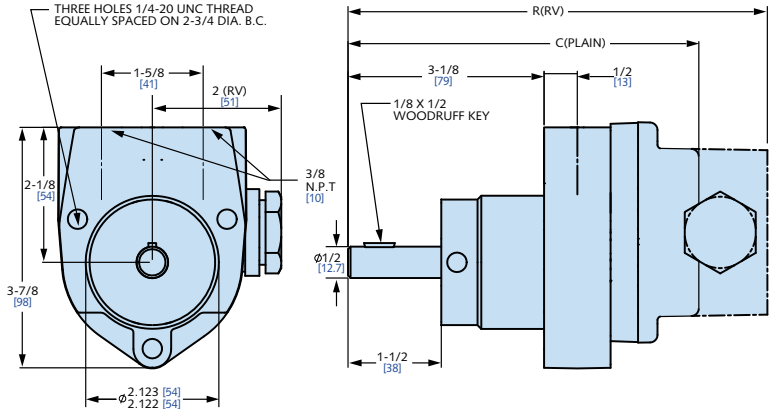

SIZE 06 THROUGH 16 (foot mounted)

PUMP	C	R	PUMP	C	R
1A-06	10-15/32 [266]		1A-12	11-5/16 [287]	
2A-06		12-5/32 [309]	2A-12		13 [330]
1A-08	10-3/4 [273]		1A-16	11-7/8 [301]	
2A-08		12-7/16 [316]	2A-16		13-9/16 [344]

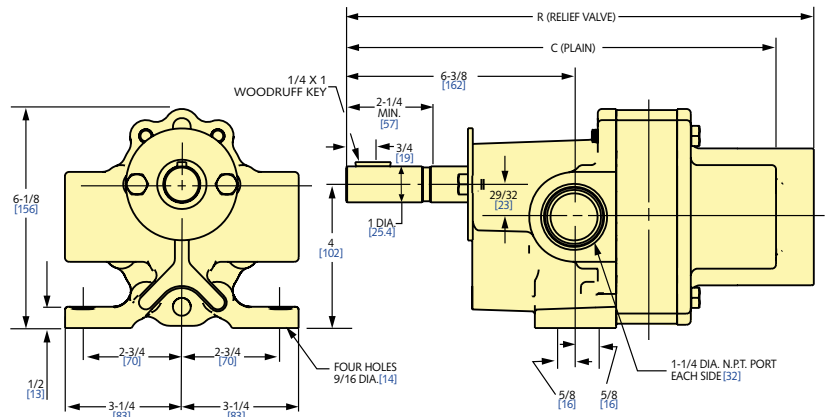

SIZE 21 THROUGH 40 (foot mounted)

PUMP	B	C	F	N-M	R	S
1A-21	3 [76]	12-5/8 [321]	1 [25]	9 [229]		1-1/2 [38]
2A-21	3 [76]		1 [25]	9 [229]	14-5/16 [364]	1-1/2 [38]
1A-27	3-3/4 [95]	13-3/8 [340]	1-3/8 [35]	9-3/8 [238]		2 [51]
2A-27	3-3/4 [95]		1-3/8 [35]	9-3/8 [238]	15-1/16 [382]	2 [51]
1A-32	4-1/2 [114]	14-1/8 [359]	1-3/4 [44]	9-3/4 [248]		2 [51]
2A-32	4-1/2 [114]		1-3/4 [44]	9-3/4 [248]	15-13/16 [402]	2 [51]
1A-40	4-1/2 [114]	14-1/8 [359]	1-3/4 [44]	9-3/4 [248]		2 [51]
2A-40	4-1/2 [114]		1-3/4 [44]	9-3/4 [248]	15-13/16 [402]	2 [51]

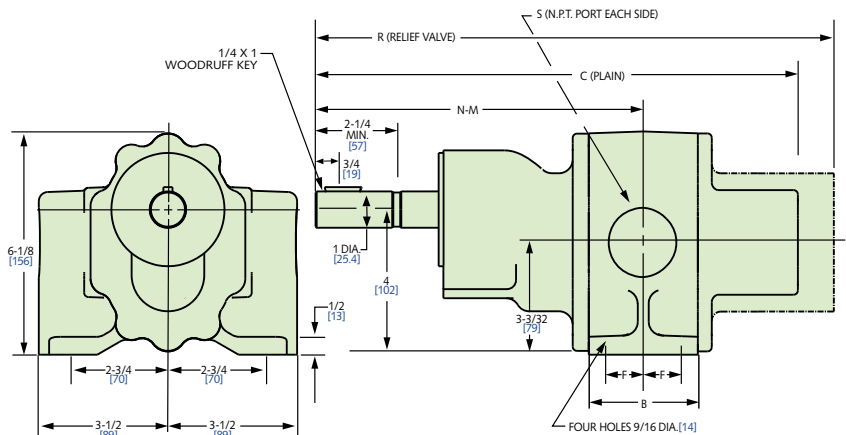

SIZE 003 (flange mounted)

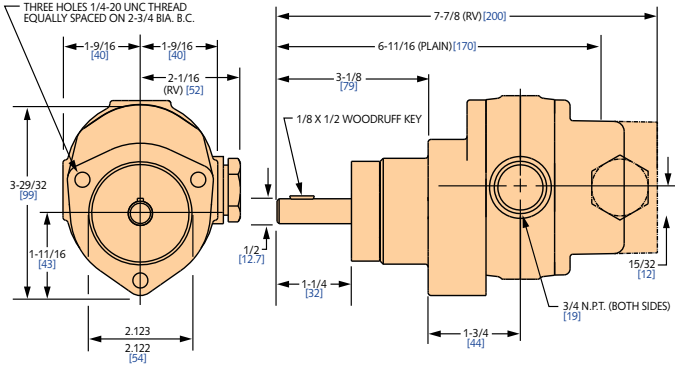

SIZE 003 (foot mounted)

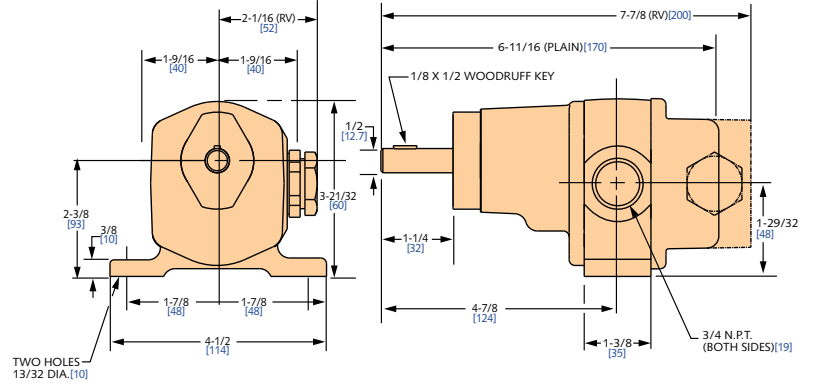

SIZE 06 THROUGH 16 (flange mounted)

PUMP	C	R	PUMP	C	R
17A-06	6-25/32 [172]		17A-12	7-5/8 [194]	
18A-06		8-15/32 [215]	18A-12		9-5/16 [237]
17A-08	7-1/16 [179]		17A-16	8-3/16 [208]	
18A-08		8-3/4 [222]	18A-18		9-3/4 [248]

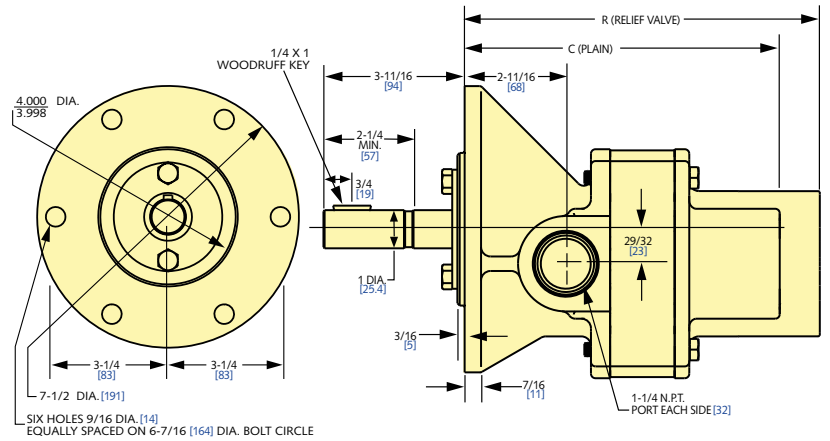

SIZE 21 THROUGH 40 (flange mounted)

PUMP	C	B-G	R	S
17A-21	8-15/16 [227]	5-5/16 [135]		1-1/2 [38]
18A-21		5-5/16 [135]	10-5/8 [270]	1-1/2 [38]
17A-27	9-11/16 [246]	5-11/16 [144]		2 [51]
18A-27		5-11/16 [144]	11-3/8 [289]	2 [51]
17A-32	10-7/16 [265]	6-1/16 [154]		2 [51]
18A-32		6-1/16 [154]	12-1/8 [308]	2 [51]
17A-40	10-7/16 [265]	6-1/16 [154]		2 [51]
18A-40		6-1/16 [154]	12-1/8 [308]	2 [51]

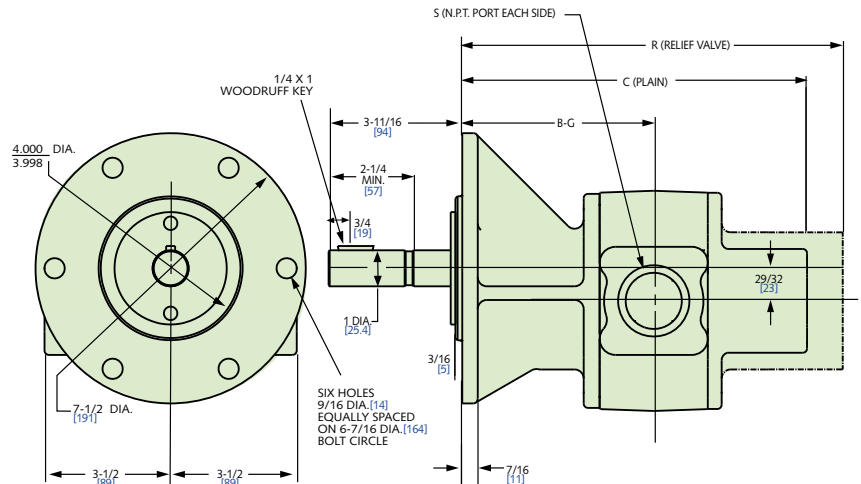

AE Series Pumps

Low Pressure • Capacities to 130 GPM
Pressures to 300 PSI

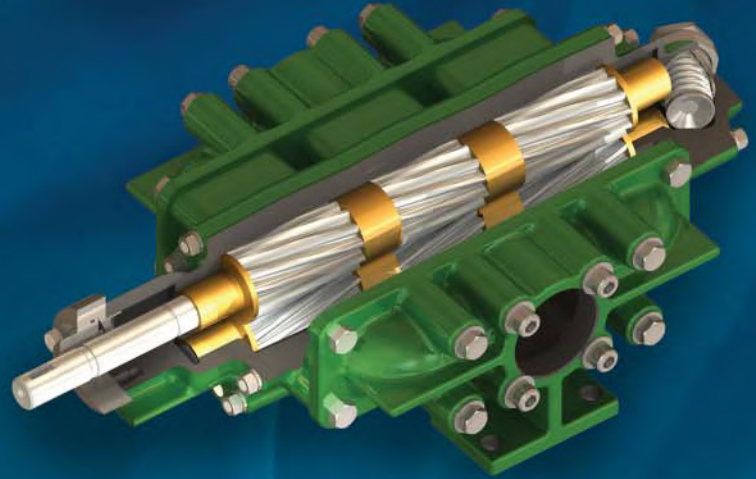

Roper AE Series pumps are well suited to applications where a compact and quiet unit is required, such as hydraulic lift applications. Bearings and wear-plates are special wear-resistant, high lead bronze. The pumping gears are accurately machined to run quietly and smoothly.

They can be operated at various speeds, depending on the conditions of installation.

SIZES AVAILABLE

- 19 019 Gallons Per Revolution
- 29 029 Gallons Per Revolution
- 54 054 Gallons Per Revolution
- 75 075 Gallons Per Revolution

MATERIALS OF CONSTRUCTION

Standard Fitted

- Housing..... Cast Iron
- Gears..... Hardened Steel
- Bearings..... Bronze
- Shafts Hardened Steel

SIZE	RPM	3600 RPM				1800 RPM			1200 RPM				900 RPM				720 RPM			
		PSI [bar]	SSU	30	100	1000	30	100	1000	30	100	1000	10,000	30	100	100	10,000	30	100	1000
19	50	GPM [l/min]	60 [227]	63 [238]	64 [242]	28 [106]	31 [117]	32 [121]	17 [64]	20 [76]	21 [79]	22 [83]	11 [42]	14 [53]	15 [57]	16 [61]	7 [26]	10 [38]	11 [42]	12 [45]
		HP [KW]	3.9 [2.9]	3.9 [2.9]	3.9 [5.1]	1.5 [1.1]	1.5 [1.1]	2.2 [1.6]	1.1 [0.8]	1.1 [0.8]	1.3 [1.0]	2.2 [1.6]	0.8 [0.6]	0.8 [0.6]	1.0 [0.7]	1.5 [1.1]	0.6 [0.4]	0.6 [0.4]	0.8 [0.6]	1.2 [0.9]
	100	GPM [l/min]	58 [220]	62 [235]	63 [238]	26 [98]	30 [114]	31 [117]	15 [57]	19 [72]	20 [76]	21 [79]	9 [34]	13 [49]	14 [53]	15 [57]	5 [19]	9 [34]	10 [38]	11 [42]
		HP [KW]	5.8 [4.3]	5.8 [4.3]	8.8 [6.6]	2.4 [1.8]	2.4 [1.8]	3.1 [2.3]	1.8 [1.3]	1.8 [1.3]	2.0 [1.5]	2.9 [2.2]	1.3 [1.0]	1.3 [1.0]	1.5 [1.1]	2.0 [1.5]	1.0 [0.7]	1.0 [0.7]	1.2 [0.9]	1.6 [1.2]
29	200	GPM [l/min]		59 [223]	62 [235]		27 [102]	30 [114]		16 [61]	19 [72]	20 [76]		10 [38]	13 [49]	14 [53]		6 [23]	9 [34]	10 [38]
		HP [KW]		9.6 [7.2]	12.6 [9.4]		4.3 [3.2]	5.0 [3.7]		3.1 [2.3]	3.3 [2.5]	4.2 [3.1]		2.3 [1.7]	2.5 [1.9]	3.0 [2.2]		1.7 [1.3]	1.9 [1.4]	2.3 [1.7]
	300	GPM [l/min]			61 [231]			29 [110]			18 [68]	19 [72]			12 [45]	13 [49]			8 [30]	9 [34]
		HP [KW]			16.5 [12.3]			7.0 [5.2]			4.6 [3.4]	5.5 [4.1]			3.5 [2.6]	4.0 [3.0]			2.7 [2.0]	3.1 [2.3]
54	50	GPM [l/min]	98 [371]	102 [386]	105 [397]	45 [170]	49 [185]	52 [197]	28 [106]	31 [117]	34 [129]	34.5 [131]	19 [72]	22 [83]	25 [95]	25.5 [97]	14 [53]	17 [64]	20 [76]	20.5 [78]
		HP [KW]	7.8 [5.8]	7.8 [5.8]	12.0 [8.9]	2.7 [2.0]	2.7 [2.0]	3.7 [2.8]	1.6 [1.2]	1.6 [1.2]	2.1 [1.6]	3.3 [2.5]	1.0 [0.7]	1.0 [0.7]	1.3 [1.0]	2.1 [1.6]	0.75 [0.6]	0.75 [0.6]	0.95 [0.7]	1.4 [1.0]
	100	GPM [l/min]	95 [360]	100 [379]	104 [394]	42 [159]	47 [178]	51 [193]	24 [91]	29 [110]	33 [125]	34.3 [130]	15 [57]	20 [76]	24 [91]	25.3 [96]		15 [57]	19 [72]	20.3 [77]
		HP [KW]	17.0 [12.7]	12.0 [8.9]	15.0 [11.4]	6.5 [4.8]	5.0 [3.7]	5.5 [4.1]	2.8 [2.1]	2.6 [1.9]	3.1 [2.3]	4.3 [3.2]	2.2 [1.6]	2.0 [1.5]	2.3 [1.7]	3.1 [2.3]		1.5 [1.1]	1.7 [1.3]	2.2 [1.6]
75	200	GPM [l/min]		96 [363]	103 [390]		43 [163]	50 [189]		25 [95]	32 [121]	34.1 [129]		16 [61]	23 [87]	25.1 [95]			18 [68]	20.1 [76]
		HP [KW]		18.0 [13.4]	22.0 [16.4]		9.0 [6.7]	9.5 [7.1]		5.0 [3.7]	5.5 [4.1]	6.6 [4.9]		3.9 [2.9]	4.2 [3.1]	4.9 [3.7]			3.1 [2.3]	3.7 [2.8]
	300	GPM [l/min]			102 [386]			49 [185]			31 [117]	34 [129]			22 [83]	25 [95]				20 [76]
		HP [KW]			29.0 [21.6]			13.5 [10.1]			8.5 [6.3]	9.6 [7.2]			5.9 [4.4]	6.6 [4.9]				5.1 [3.8]

NOTE: Consult your local Roper Pump Company representative for operation in the range indicated by the yellow colored areas.

AE Series Dimensions

SIZE 19 THROUGH 29 (foot mounted)

PUMP	B	C	F	N-M	R	S
1AE-19	3 [76]	12-5/8 [321]	1 [25]	9 [229]		1-1/2 [38]
2AE-19	3 [76]		1 [25]	9 [229]	14-13/16 [376]	1-1/2 [38]
1AE-29	4-1/2 [114]	14-1/8 [359]	1-3/4 [44]	9-3/4 [248]		2 [51]
2AE-29	4-1/2 [114]		1-3/4 [44]	9-3/4 [248]	15-13/16 [402]	2 [51]

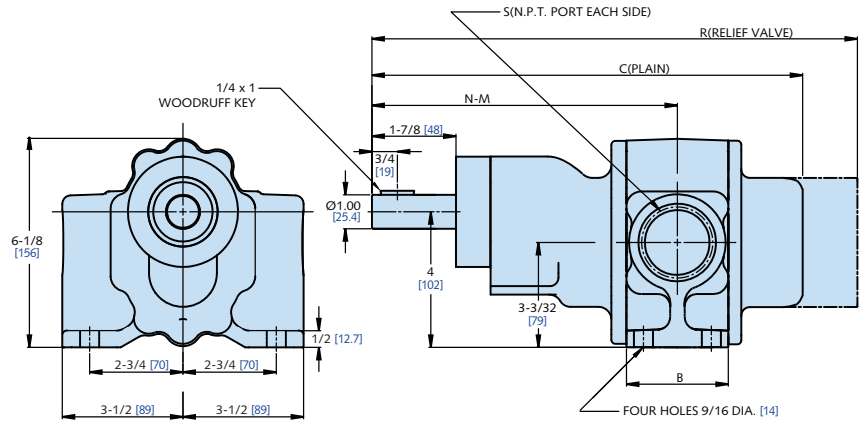

SIZE 54 (foot mounted)

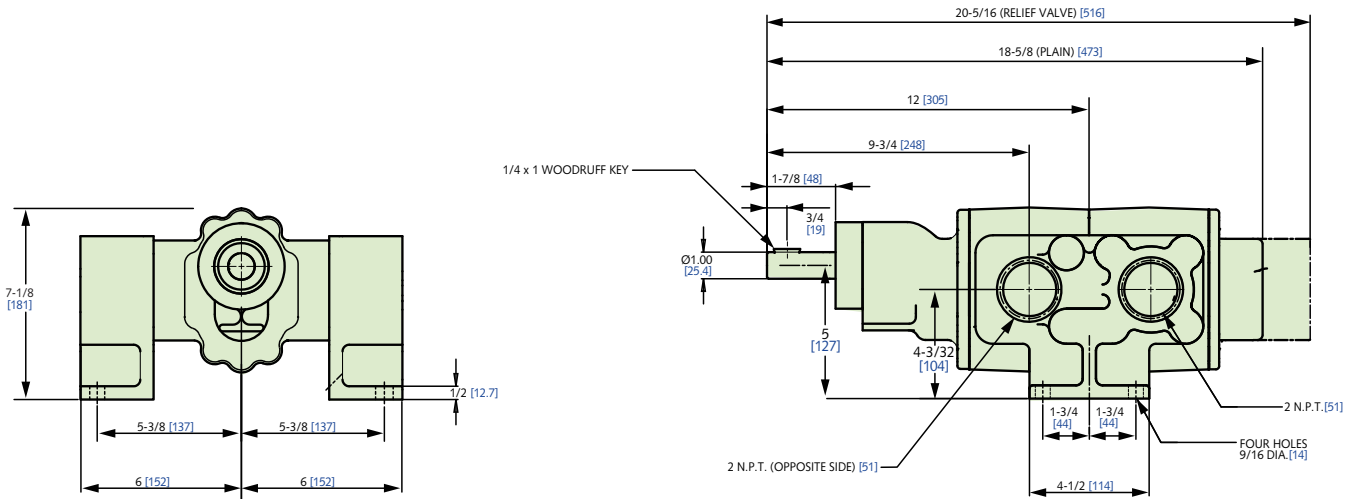

SIZE 75 (foot mounted)

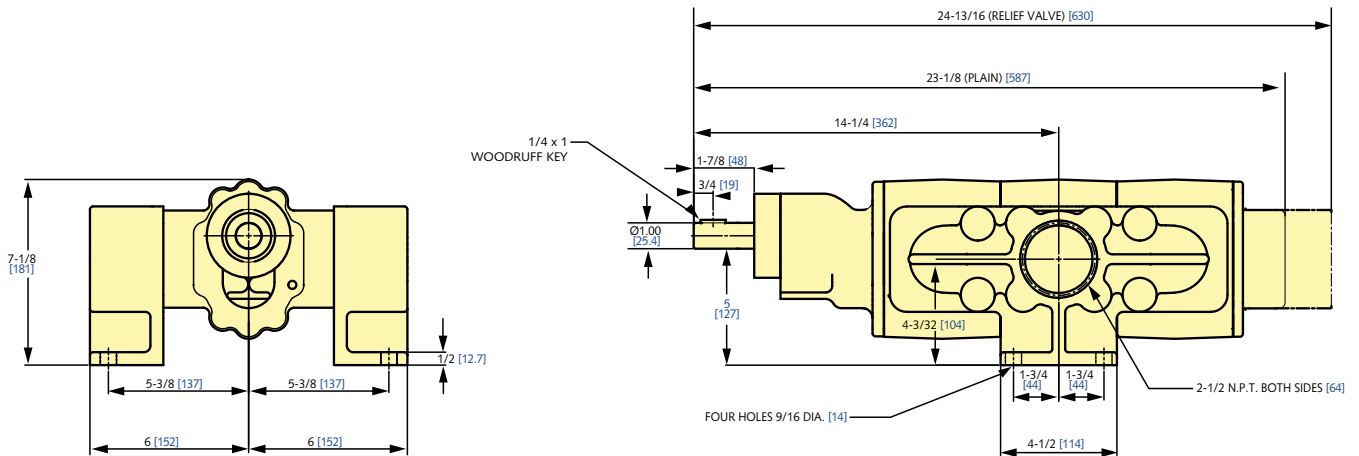

CELEBRATING

50

YEARS OF EXPERIENCE

**EXPERIENCE INNOVATIVE
THINKERS AND PRODUCTS**



ALL ABOUT EXPERIENCE

allpumps.com.au

1300 255 786 | sales@allpumps.com.au