

ULTIMA SERIES

Gebruiksaanwijzing
Mode d'emploi
Instruction manual
Betriebsanleitung



CONTENTS

1	INTRODUCTION	
1.1	General Information	3
1.2	Manufacturer	3
1.3	Copyright	3
1.4	Declaration of conformity	4
1.5	Principle of operation	5
1.6	Intended Use	5
1.7	Type designation	5
1.8	Sound pressure level	6
2	SAFETY	7
3	INSTALLATION	
3.1	Unpacking and lifting of the pump	8
3.2	Operating limitations	8
3.3	Location & orientation	8
3.4	Drives	10
3.5	Baseplate	11
3.6	Guards and safety	11
3.7	Electrical connection of the motor	11
3.8	Ports and pipework	13
3.9	Enlarged rectangular inlet	13
3.10	Temperature control jackets	13
3.11	Seals and flushing	14
3.12	Seal materials	16
3.13	Lubrication	17
4	START UP & ROUTINE CHECKS	
4.1	Start up	17
4.2	Daily checks	18
4.3	Weekly checks	18
4.4	Monthly checks	18
4.5	Six monthly checks	18
4.6	Annual checks	18
5	CLEANING AND STERILISATION	
5.1	Cleaning in place (CIP) & manual cleaning	19
5.2	Sterilizing in place (SIP)	20
6	INSPECTION AND REPAIR	
6.1	End cover	21
6.2	Rotors	22
6.3	Primary seals	22
6.4	Mechanical shaft seals – single flushed	24
6.5	Secondary mechanical seals – double	25
6.6	Seal housings	25
6.7	Rotor case	26
6.8	Rotor clearance – checking and adjustment	27
6.9	Thermal jacket – end cover	28
6.10	Thermal jacket – pump head	28
6.11	Bearing housing – inspection & repair	28
6.12	Gearbox shafts, gears and bearings	29
6.13	Bearing set-up and preload	29
7	ATEX APPLICATIONS	31
8	EXPLODED DIAGRAMS	
8.1	Ultima exploded diagram	32
8.2	Options & Extras – sectional views	33

1 INTRODUCTION

1.1 GENERAL INFORMATION

Thank you for purchasing PACKO products!

This manual for the Ultima series Rotary Lobe Pumps describes the safe and appropriate installation, use, disassembly and assembly, maintenance and troubleshooting of the pump.

Read and completely understand this manual to learn how to service these pumps prior to operating or servicing the product and observe to pay special attention to the warnings.

This manual must always be available at the installation location since no liability will be assumed for any damage or operational malfunctions arising from non-compliance with these operating instructions.

1.2 MANUFACTURER

JEC LTD
15-26, Beodeul-ro 1362, Paltan-myeon,
Hwaseong-si,
Gyeonggi-do, 18578, Rep. of Korea
Telephone: +82 31 355 0316
Telefax: + 82 31 355 0319
E-mail: export.kr@jec.verder.com

1.3 COPYRIGHT

These operating instructions are written to support the installation, the use and the maintenance of the pump in accordance with the European machinery directive. They are originally written in Dutch, English, French and German by the manufacturer. All other languages are translations of the original operating instructions.

PACKO INOX LTD has the copyright on this document. These operating instructions may be reproduced in full in the operating instructions of the machine or installation in which the pump is installed and may be used for training personnel who must work on or with the pump. Any other publication, reproduction in full or parts thereof is prohibited.

Although these operating instructions have been carefully drawn up, they do not however cover all possible eventualities that can occur during the installation, operation or the maintenance of the pump. In any event, the pump must not be used for purposes other than those stated when ordering and for which the pump has been constructed, as this could result in physical damage and injuries.

1.4 DECLARATION OF CONFORMITY

Declaration of conformity according to annex IIA of the "Machinery" Directive 2006/42 EC

We,

JEC LTD
15-26, Beodeul-ro 1362, Paltan-myeon, Hwaseong-si,
Gyeonggi-do, 18578, Rep. of Korea

confirm that the Packo pump type, with serial number
fully complies with the Directive Machinery and with the (harmonised) standard EN 809, ENISO12100.

It must be brought to your attention that our product is intended to be built into a machine, and that, on the basis of the "Machinery" Directive, the complete (compound) machine can only be applied after matching the stipulations of the European demands.

JEC LTD 15-26, Beodeul-ro 1362, Paltan-myeon, Hwaseong-si, Gyeonggi-do, 18578, Rep. of Korea is authorized to make up the technical construction file.

Date

.....

Signature:

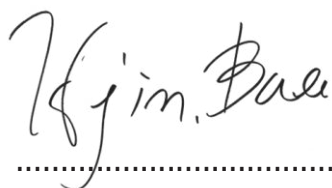

.....

JEC Ltd

1.5 PRINCIPLE OF OPERATION

LU pumps have 2 rotors which turn in opposite directions. Fluid enters the pump from the inlet port and fills the space between the rotors. This fluid is carried around the outside of the rotors and is forced out of the discharge port as the rotor lobes mesh together see Figure 1. Each rotor is supported on a shaft and when the pump is running within its operating limits, the rotors never touch the inside of the rotor case, or each other.

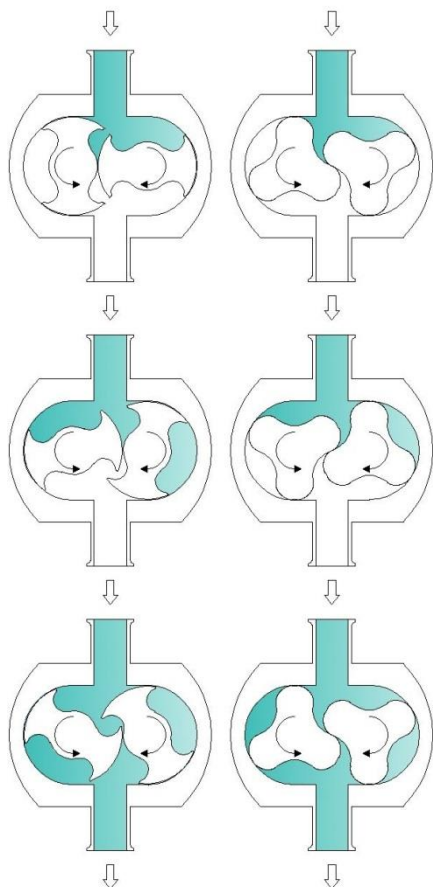

Figure 1 - Principle of operation (Showing vertical mounting)

1.6 INTENDED USE

The pump should only be used for pumping the media it was selected for and within the limits specified in the technical datasheets. Any other application beyond the intended use or conversion of the pump without written agreement with the manufacturer shall be deemed to be not in accordance with the intended use.

The pump may only be started up for the first time if it has been ensured that all safety devices are completely fitted and functional.

If any areas are subject to have the risk of explosion, the relevant explosion-proof designed pumps should be used.

Intended use also covers compliance with the conditions of operation, servicing and maintenance specified by the manufacturer.

The pump is only to be put into operation filled with medium to be pumped.

Before starting up pay attention to:

- Open the valves on the suction side completely to avoid cavitation and,
- Open the valves on the discharge side completely to avoid exceeding the permitted differential pressure of the pump
- Discharge-side safety measures should be done (e.g. safety valve) to protect the pump from non-permitted excess pressure
- Protection against contact for hot, cold and moving parts must not be removed during operation

1.7 TYPE DESIGNATION

The type designation can be found on the pump name plate and also on both the order confirmation and customer invoice.

JEC LTD HWASEONG KOREA		Packo
TYPE:		
⊕ Mat.code:		⊕
Year:	S/N:	kg
Max:	bar	°C
DO NOT RUN PUMP DRY OR AGAINST CLOSED VALVE		CE

Example (an X in the code denotes a special version):

Type: LU/44-213/114

- LU: pump series
- 44: pump type
- 213: Speed of the pump when the motor operates at 50Hz
- 11: motor power in kW multiplied by ten (11 = 1.1 kW)
- 4: number of poles of the motor

Mat. Code: (SCHP-95) D37SSVQ

- SCHE = scimitar high efficiency, SCHP = scimitar high pressure)
- 95: temperature class of the pump (Deg. C)
- D: type of couplings T = Tri-Clamp ISO2852, V = DIN 11864-1, A = DIN 11864-2)
- 37: housing size of the NORD reductor
- S: seal configuration (S = standard single seal, Q = quench, D= double mechanical seal)
- S: mechanical shaft seal materials (S = silicon carbide / silicon carbide, K = carbon / silicon carbide)
- V: elastomer materials (E = EPDM, V = viton, M = teflon)
- Q: options (T = pump and motor reductor on trolley, U = pump and motor reductor on trolley with cover, P = bare shaft pump, Q = pump and motor reductor aligned on base plate, R = pump and motor reductor aligned on base plate with cover)

Moreover, the year and week of construction, the pump serial number (to be stated when ordering spare parts), the weight, maximum operating temperature and maximum differential pressure are also marked on the name plate.

1.8 SOUND PRESSURE LEVEL

The sound-pressure level of the pump, operating at 50Hz without cavitation measured at 1m is less than 70dB(A). In order to minimize noise and vibration, no other parts of the machine may vibrate at the same time as the pump. The best solution is therefore to allow the pump to rest directly on the concrete floor, or to fit shock absorbers between the pump and the frame of the machine.

2 SAFETY

Throughout this manual your attention is drawn to certain procedures which must be followed to ensure safe operation and servicing of this product.



ATTENTION

Do not ignore safety instructions.



ATTENTION

Do not remove by-pass or tamper with safety devices.



ATTENTION

Do not use this equipment if the end cover (122) is removed, guards are missing or inlet & outlet pipework is not connected.



ATTENTION

Do not forget the hazards of moving parts, high fluid pressure, extremes of temperature, hazardous liquids, electricity.

Always isolate and lock-out the pump drive motor before inspecting or servicing the pump.



ATTENTION

Heavy lifting and work only to be done by suitably trained personnel.

3 INSTALLATION

Careful attention to correct installation of LU pumps, and recognition of certain limitations to the operating conditions of the pump, will ensure long life and trouble-free running.



ATTENTION

Failure to follow these instructions could result in personal injury or loss of life.

Take particular care over the following:

3.1 UNPACKING AND LIFTING OF THE PUMP

Unpack the pump/unit upon delivery and inspect it for visible transport damage.

Any damage occurred during the transporting has to be immediately reported to the transport agent after receipt of the consignment. Do not put the damaged products into operation.

The pumps need to be transported and secured with care to ensure no damage is caused. Smaller pumps without motor weigh less than 20kg and can be lifted by hand. Larger pumps with lifting eye bolt and complete units should be lifted as shown on the below pictures. Straps with sufficient load capacity must be used.

Make sure you set the pump down on a stable horizontal surface.

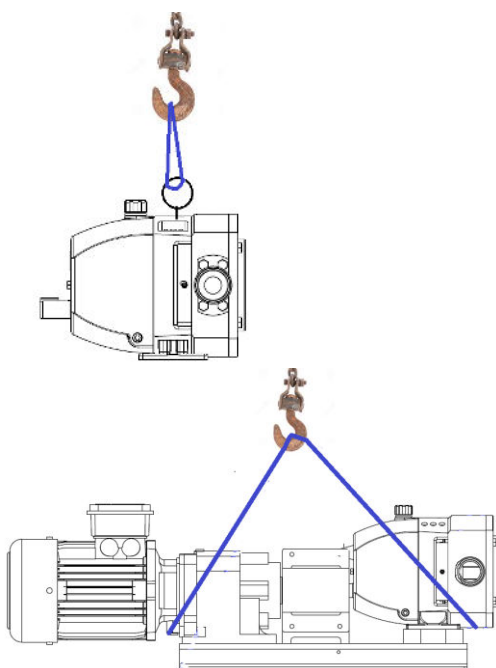

3.2 OPERATING LIMITATIONS

PRIMING: LU pumps are not truly self-priming and should be installed in a "flooded inlet" pipe arrangement i.e. with the pump lower than the level of liquid to be pumped and with the supply pipe falling continuously to the pump with no loops.

PRESSURE: Do not operate the pump above the maximum differential pressure shown on the nameplate, not even for a few seconds, as damage to the pump components will result, leading to metal particles in the pumped fluid, ineffective cleaning and possibly complete pump seizure.



ATTENTION

Never run the pump against a closed valve. Note that the pressure limit varies with the temperature.

SOLIDS: LU pumps can handle soft solids in suspension but will be damaged by hard particles. Take care when pumping solids, crystals, etc.

Never allow metal parts to enter the pump, i.e. weld metal, screws, tools, etc. as these will stop the pump, leading to damaged rotors, rotor case and shafts.

CAVITATION: The pumps cannot operate without sufficient pressure of liquid at the inlet port of the pump. Normally atmospheric pressure is sufficient but the actual pressure needed, is higher for:

- High Viscosities
- High Temperature
- High Pump Speeds
- Volatile Liquids

Insufficient inlet pressure will cause the pump to cavitate leading to low performance, noise and short pump life. Ensure inlet pipes are short, large bore and do not collapse under vacuum.

3.3 LOCATION & ORIENTATION

The pump should be located:

- As close as possible to the fluid source and as low as possible to maximize the net inlet pressure available to the pump.
- In a clear area allowing access all around the pump and drive for easy servicing.
- With space above for lifting equipment required.

- With the port axis vertical if pump is required to be self-draining.

All LU pumps are equally suitable for both directions of rotation.

LU pumps can be rotated to give horizontal port orientation with top or bottom input shaft positions or vertical port orientation with left or right input shaft positions.

See Figure 2, Figure 3, Figure 4 & Figure 5.

This is achieved with the bolt-on feet and re-positional gear cover. (Ensure gearbox is drained of oil prior to gear cover removal)

To change any pump from vertical to horizontal pipework or vice versa, the correct foot kit needs to be applied. Foot kits contain all components required to change orientation.

See below for the orientation setup after the packing feet have been removed.

To orientate the pump for:

Horizontal Ports Top Shaft Drive

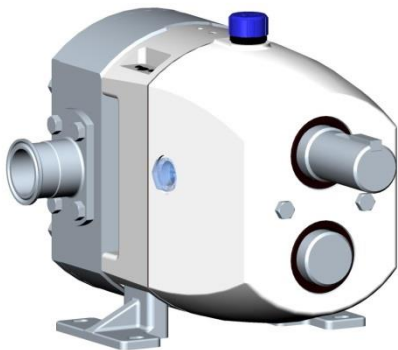

Figure 2 - Horizontal ports top shaft drive

- Remove black hole covers from foot location recess and place in a safe location (33 & 34)
- Push foot home until foot face mates with foot location recess face.
- Fit foot bolts (21) (Supplied in foot kit) through the feet into the bearing housing (1) and tighten to torque specified in Table 1.
- Repeat process for 2nd foot.
- Refit black hole covers into top foot location recesses.

Horizontal Ports Bottom Shaft Drive

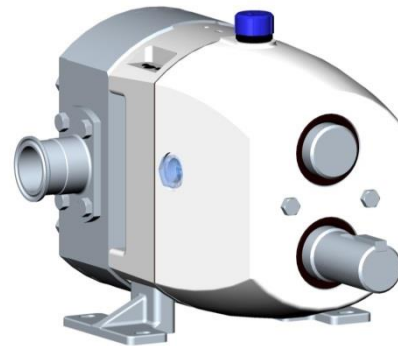

Figure 3 - Horizontal ports bottom shaft drive

- Remove the black hole covers from the foot location recess and place in a safe location (33 & 34)
- Push the foot home until the foot face mates with the foot location recess face.
- Fit the foot bolts (21) (Supplied in the foot kit) through the feet into the bearing housing (1) and tighten to the torque specified in Table 1.
- Repeat the process for the 2nd foot.
- Refit the black hole covers into the top foot location recesses.
- Remove the key (29) from the drive shaft end.
- Remove the 2 bolts (18) from the gear cover (11) and slide the cover off of the shaft end, being careful not to damage the inside of the lip seal on the edges of the keyway in the shaft. Rotate the gear cover 180° and re-fit by tightening the 2 bolts. Tighten to the torque specified in Table 1.

Vertical Ports Left Shaft Drive (When viewed from front)

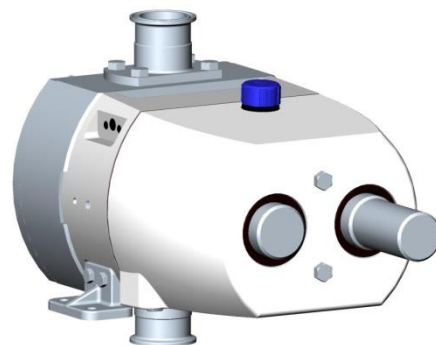

Figure 4 - Vertical ports left shaft drive

- Remove the black hole covers from the foot location recess and place in a safe location (33 & 34)
- Push the foot home until the foot face mates with the foot location recess face.
- Fit the foot bolts (21) (Supplied in the foot kit)

kit) through the feet into the bearing housing (1) and tighten to the torque specified in Table 1.

- Repeat the process for the 2nd foot using the top right foot location recess.
- Refit the black hole covers into the left foot location recesses.
- Remove the breather plug (12) and sight glass (13) and swap their positions. Tighten the breather plug and sight glass to the torque specified in Table 1.

Vertical Ports Right Shaft Drive
(When viewed from front)

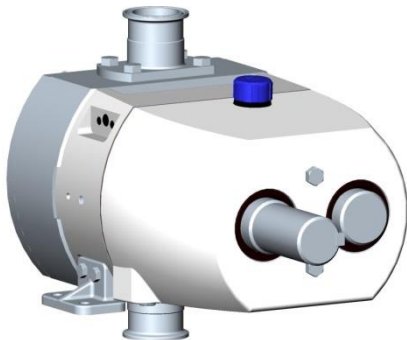

Figure 5 - Vertical ports right shaft drive

- Remove the black hole covers from the foot location recess and place in a safe location (33 & 34)
- Push the foot home until the foot face mates with the foot location recess face.
- Fit the foot bolts (21) (Supplied in the foot kit) through the feet into the bearing housing (1) and tighten to the torque specified in Table 1.
- Repeat the process for the 2nd foot using the top left foot location recess.
- Refit the black hole covers into the left foot location recesses.
- Remove the key (29) from the drive shaft end.
- Remove the 2 bolts (18) from the gear cover (11) and slide the cover off of the shaft end, being careful not to damage the inside of the lip seal on the edges of the keyway in the shaft. Rotate the gear cover 180° and re-fit, tightening the 2 bolts. Tighten to the torque specified in the torque table below.
- Remove the breather plug (12) and the sight glass (13) and swap their positions. Tighten the breather plug and the sight glass to the torque specified in Table 1

Pump Size	Fixing	Torque Nm
LU4	Foot Bolt	25
	Gear Cover Bolt	8
LU5	Foot Bolt	72
	Gear Cover Bolt	10
LU6	Foot Bolt	72
	Gear Cover Bolt	10
Feet bolts should have thread lock applied before fitting such as 'Loctite 243 Thread Lock'		

Table 1 - Torque Table

3.4 DRIVES

If the LU pump was supplied in bare shaft form i.e. without a drive motor, the drive must be selected and supplied to suit each individual application.

Pay attention to special motor requirements.

- Explosion/flame proof
- Hose proof/splash proof
- High ambient temperature
- Frequent stop/starts
- Materials of construction
- Available electrical voltage and frequency

Provision of a variable motor speed (i.e. by frequency inverter), is always recommended to enable flow to be accurately set, accommodate changes in fluid viscosity, changes in temperature, or to run the pump faster for cleaning. Variable speed motors must be selected to accommodate the full power and torque requirements throughout the operating speed range.

Transmission to the pump shaft will normally be by one of the following:

Direct Coupling:

If synchronous motor speeds can be matched to the required pump speed, the drive can be via a proprietary flexible shaft coupling.

A torque limiting coupling can protect the pump against overload.

In all cases the coupling manufacturer's limits should be adhered to.

See performance curve to calculate torque.

Pump and motor shafts should be accurately aligned in accordance with the coupling manufacturer's instructions.

Motor reductor:

For pump speeds lower than synchronous motor speeds, a proprietary motor reductor may be fitted. Variable ratio units are available to allow the pump speed to be adjusted. Coupling to the pump will be as in above bullet point.

- Guards in hazardous areas must be made from non-sparking material.
- Guards must be securely fixed.
- Pump must not be operated with guards removed.

3.5 BASEPLATE

The pump and drive will normally be mounted on a common baseplate or frame which must be strong and rigid enough to withstand the drive reaction forces as well as to support the equipment without vibration. Ensure the base is level as distortion could affect coupling alignment. Always check the pump to drive alignment after installation and before starting the pump.

For hygienic applications, the following conditions should also be met:

- Baseplates should be constructed from stainless steel or coated/painted mild steel.
- Legs, when used, must have either rounded ends or have flat load bearing feet suitable for floor mounting with no exposed threads.
- Legs made from hollow stock must be sealed.
- Baseplates should be sealed to the floor.

3.6 GUARDS AND SAFETY



ATTENTION

The machinery is incomplete and must not be put into service until the machinery into which it is to be incorporated has been declared in conformity with the provisions of the Directive.



ATTENTION

All moving parts must be guarded, and in accordance with the applicable Directive.

Local safety regulations and codes of practice will specify the minimum acceptable standard but as a guide:

- Couplings, belts and pulleys must be enclosed to prevent fingers, clothing or tools from touching moving parts.
- Guards must be made from corrosion resistant materials.

3.7 ELECTRICAL CONNECTION OF THE MOTOR

The electrical connections may only be made when no electrical power is connected and by qualified personnel in accordance with EN 60204 and the local regulations. Special attention must be paid to optimal earthing of the motor; this must be performed in accordance with the applicable regulations in the relevant country. Check on the name plate of the motor whether the motor can operate from the available voltage and frequency.

The connecting cables and the protection system against excessive currents must be chosen according to the data on the name plate of the motor. The voltage drop during the starting of the motor may not exceed 3 %.

Tighten the nuts of the connector terminals in accordance with the torque values (Nm) stated below:

Terminal	M4	M5	M6	M8	M10	M12	M16
Steel	2	3.2	5	10	20	35	65
Copper	1	2	3	6	12	20	50

Do not install any washers or nuts between the cable lugs of the motor windings and the cable lugs of the connecting cables.

Inspect the seal of the gland. The gland must match the diameter of the connecting cable used. Bending of the cable beside the gland must not allow water to penetrate. (Allow the cable to be routed downwards when it leaves the motor.)

Connect the motor in star or delta according to the designation on the name plate of the motor and in accordance with the diagram that is installed in the terminal box. Do not connect the motor if you have any doubts regarding the interpretation of the connection diagram. If in doubt please contact JEC. Never check the direction of rotation of the pump when the terminal box is open. The technician is responsible for complying with the regulations relating to electrical compatibility in the country where the pump is installed.

The voltage and the frequency stated on the name plate of the motor must be observed. (Tolerance of 5 % for the voltage, and 1 % for the frequency.)

For pumps whose power exceeds 7.5 kW, special starting provisions must be provided (star-delta starter, soft starter, or starting with frequency converter).

The installation of an overcurrent protection device is always mandatory.

3.8 PORTS AND PIPEWORK

Pipe runs and sizes should be established at the time the pump is selected.

When installing the pump do not deviate from this design without rechecking the pump selection:

- Keep pipe runs short and pipe diameters large; pipes may need to be larger diameter than pump ports especially when pumping viscous liquids to prevent cavitation.
- Use large radius bends and full bore valves. Avoid globe or needle valves on viscous fluids.
- Fit isolation valves on each side of the pump to simplify maintenance.
- Fit vacuum/pressure gauges on each side of the pump to monitor the pressure conditions. Once the process is established (and will not change), these can be removed.
- Avoid filters on the inlet side of the pump if possible. A clogged filter will cause cavitation. A strainer - maximum hole size 50 microns - will help to protect the pump from damage by particles, but must be kept clear.
- Support the pipework - the weight of the pipe and the fluid within may not rest on the pump.
- Fit expansion joints if necessary to prevent thermal expansion forces being transmitted to the pump.
- Ensure all pipe joints are:
 - Air-tight under vacuum;
 - Liquid tight under pressure, and;
 - Steam tight where applicable.
- Take special precautions when pumping hazardous, hot, toxic or bacteriological fluids - special joints and high specification seals may be required.
- Use hot water/steam jackets or electrical resistance tape to heat pipes carrying liquids which thicken when cool. Provide an interlock to prevent the pump from running unless the liquid in the pipes is at correct temperature to avoid over pressure, cavitation, or excessive drive shaft loads.

3.9 ENLARGED RECTANGULAR INLET

The weight of the hopper (Including the product it

contains) must be supported separately and is not allowed to rest entirely on the pump as this would affect the rotor clearances leading to pump seizure. The mating flange of a hopper or screw feeder should be machined to the identical dimensions of the rectangular inlet and sealed. This will avoid ledges where product could 'hang up'. Ensure effective flow of viscous material into the pump.

3.10 TEMPERATURE CONTROL JACKETS

Pumps are available with optional temperature control jackets. These allow hot or chilled water, oil or steam to be piped to the pump to maintain the product temperature in the pump or to heat the pump prior to starting.

Pump Head – Thermal Jacket



Figure 6 - Pump head - thermal jacket

Can be used in conjunction with end cover relief valve.

End Cover – Thermal Jacket



Figure 7 - End cover - thermal jacket

Application limits are:

- Jacket Pressure: 2 bar (30 psi).

- Temperature: 130°C (265°F).

3.11 SEALS AND FLUSHING

Three basic types of mechanical face shaft seal are available on the LU pumps.

The correct type should have been selected when the pump was originally selected but you must establish that the seal fitted is suitable for the application before starting the pump.

Provide flushing system as required.

The **Single Mechanical Seal** is suitable for many clean fluids which do not require a more sophisticated seal type. (Figure 8)

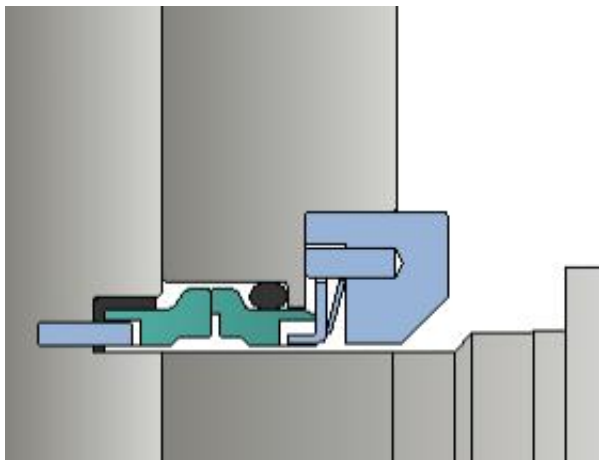

Figure 8 - Single mechanical seal (Size 4-6)

Note that silicon carbide-on-silicon carbide, seals are not recommended for steam-purged applications as the seal faces can bind together – see chapter 5 CLEANING AND STERILISATION.

Pumps fitted with single seals require no special installation.

However, pumps must never run dry, as this will cause excessive heating of the seal faces.

Use flushed seals in pumps that need to run dry.

The **Flushed Mechanical Seals** fitted to LU pumps are run with a low-pressure liquid flush between the primary mechanical seal and a lip seal to form a barrier between the pump and the atmosphere.

This allows the pump to be used for applications where the single seal is unsuitable. (Figure 9)

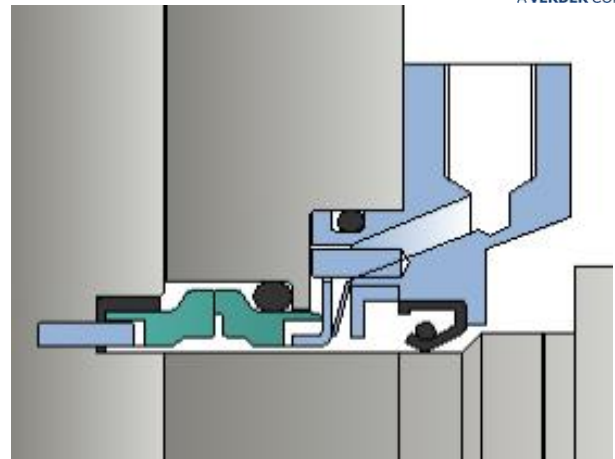

Figure 9 - Flushed single seal (Size 4-6)

Flushed seals are used when:

- Pumped fluid changes state in contact with air, i.e. crystallizes, forms a film, dries out or precipitates solids. The flush dissolves and rinses away the small amount of residue which could build up on the edges of the seal faces.
- Pumped fluid is close to its boiling point, e.g. water over 80°C (175°F). The flushing fluid is used to cool the seal faces.
- Pumped fluid is temperature sensitive and evaporates when heated by the shearing action of the seal faces. The flushing fluid is used to cool the seal faces.
- Pump may run "dry", i.e. no liquid in pump chamber for very short periods.
- Pump is under high vacuum.
- A low pressure sterile barrier is required.

A low-pressure flushing fluid system must be installed as follows:

- Liquid must be compatible with the pumped fluid; water is the most commonly used liquid.
- Pressure shall typically be 0.5 bar (7 psi) gauge. Maximum of 1.0 bar (14.5 psi) gauge.
- Temperature shall be maximum of 70°C (160°F) for water, less for volatile liquids (minimum 20°C (68°F) below boiling point of liquid).
- Flow rate shall preferably be 2 to 3 litres/min. (0.5 to 0.75 US gal/min) per seal.
- Flush fluid should be connected to enter at the lowest point on the seal housing and

flow out at the highest point to vent air pockets.

- Pipework should be as shown in the diagram (Figure 10).

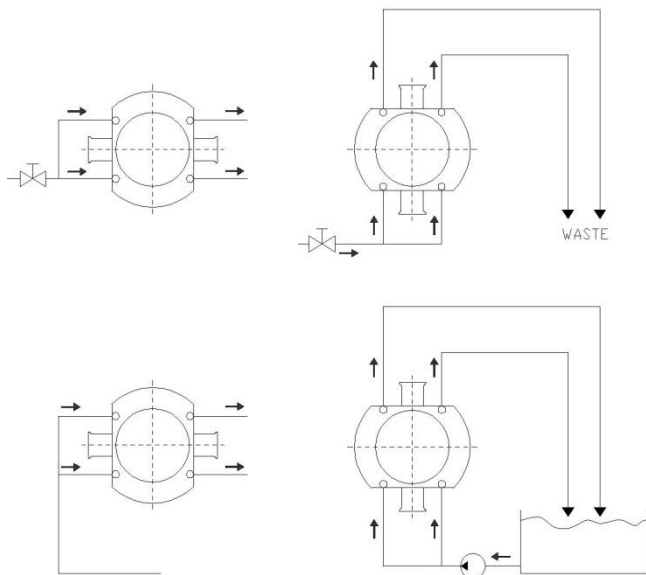

Figure 10 - Suggested low pressure flushing system

The **Double Mechanical Seals** fitted to LU pumps provide the facility to contain a high pressure fluid behind the primary seal. This allows the pump to be used for applications where the single seal is unsuitable.

Double seals code D are run with a fluid between the primary and secondary mechanical seals to form a barrier between the pump and the atmosphere. (Figure 11)

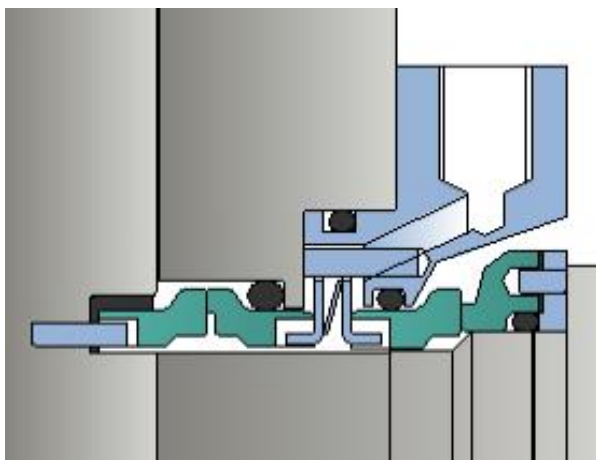

Figure 11 - Double mechanical seal (Size 4-6)

liquid flush when:



ATTENTION

- The pumped fluid is toxic or hazardous and must not escape from the pump even in minute quantities.
- The system can be installed as in figure 10, but must be capable of withstanding the full pressure within the pumped fluid pipe system.

Double Mechanical Seal with a high pressure liquid flush when:

- The pumped fluid has no lubricating properties and cannot be allowed onto seal faces
- The pumped fluid is highly viscous, i.e. over 150,000 cP.
- A high pressure sterile liquid barrier is required.

When the double seal is used with a high pressure liquid flush for the reasons described above, a flushing system must be installed as follows:

- The flushing liquid used must itself be compatible with the pumped fluid and must itself not require a complex seal, i.e. must be non-hazardous, non-abrasive and lubricating.
- Flush liquid must be at a pressure of 1 bar (15psi) above the discharge pressure of the pump and should flow at 35 to 55 litres/hour (10 to 15 US gal/hour) per seal.
- Flush fluid should be connected to flow in at the lowest point on the seal housing and out at the highest point to vent air pockets.

Refer to the drawing below for the suggested liquid flush system (Figure 12).

Double Mechanical Seal with a low pressure

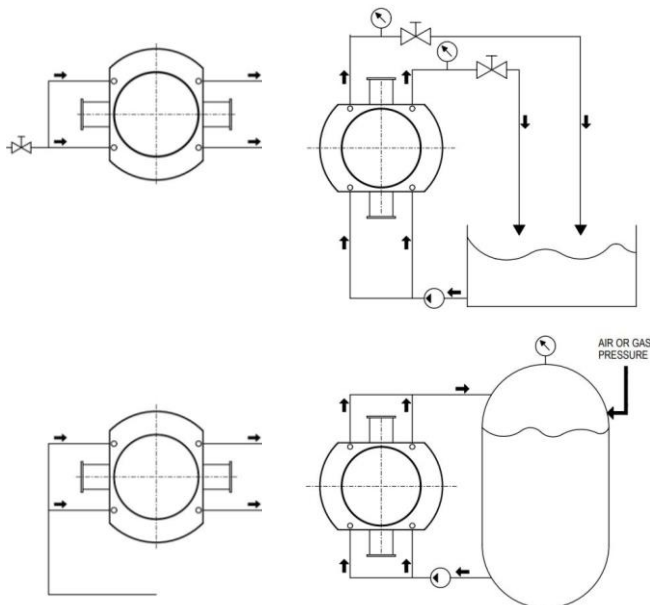

Figure 12 - High pressure liquid supply for double seals

Double Mechanical Seal with steam when:

No bacteria or contamination can be allowed to enter the pump, i.e. an aseptic system.

A steam barrier system must be installed as follows:



ATTENTION

- Wherever possible, sterile liquid i.e. steam condensate should be used as a flush. Condensate should be connected to flow in at the lowest point on the seal housing and out at the highest point to vent air pockets.
- Where steam is essential, great care must be taken with the design of pipework, steam traps and controls.
- Steam must be clean, filtered and wet, i.e. not superheated.
- The pressure of steam should be as low as possible consistent with the desired temperature.
- Steam should be connected in at the highest point on the seal housing and out at the lowest point to allow any condensate to drain from the lowest point.
- Refer to Figure 13 for suggested steam connection.

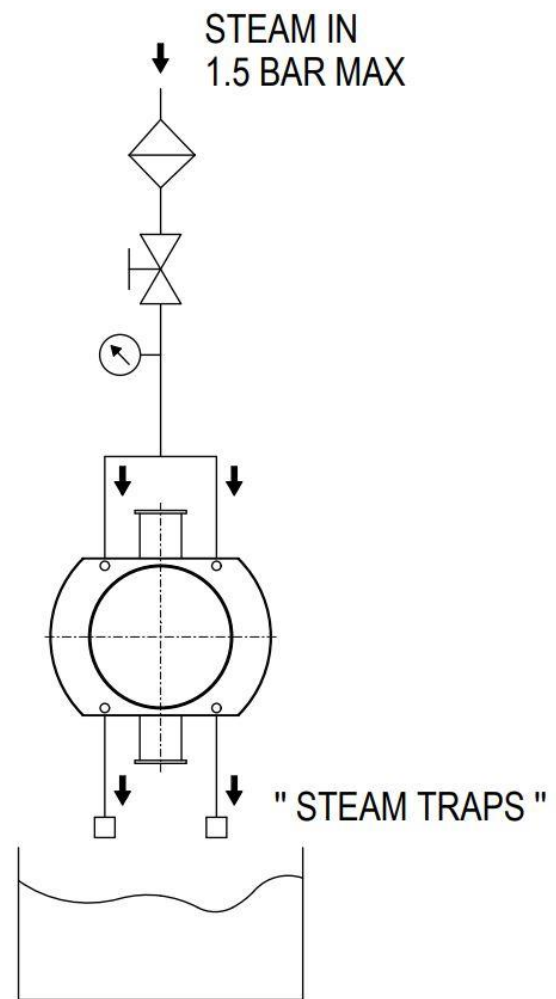

Figure 13 - Steam barrier flush system for double mechanical seal



ATTENTION

Silicon carbide on silicon carbide seals are not recommended for steam flushed applications.

3.12 SEAL MATERIALS

SEAL FACES

All primary seals are available with carbon on-silicon carbide faces for non-abrasive fluids and silicon carbide on-silicon carbide faces for abrasive fluids containing crystals, powders or particles or when no particles of wear can be allowed to enter the pumped fluid. Silicon carbide-on-silicon carbide seals are not recommended for steam flushed applications.

All secondary double mechanical seals are with carbon on silicon carbide faces.

ELASTOMERS

Product contacting primary elastomers must be selected to be compatible with the product and the process operation.

Consideration must be given to chemical compatibility, temperatures and material standards. LU pumps are available with a range of elastomers:

LU
EPDM EU, FDA, 3A
Viton EU, FDA, USP grade
PTFE USP quality

Table 2- Elastomer approvals

Consult the supplier for more information.

3.13 LUBRICATION

Packo LU pumps have oil lubricated shaft bearings and timing gears.



ATTENTION

Pumps are supplied with Nevastane XSH150 oil in the bearing housing.

- After the first 120 hours of service, drain the lubricating oil from the bearing housing and refill with fresh oil of the correct grade.
- Check oil level regularly and top up as necessary.
- Any substantial oil losses should be investigated immediately.

Oil capacity gearbox:

Pump model	Oil capacity
LU/42 & 44	0,66 liter
LU/52 & 54	1,17 liter
LU/62 & 64	2,20 liter

4 START UP & ROUTINE CHECKS

4.1 START UP

Before starting the pump for the first time or after servicing or maintenance work, check the following - failure to do so could damage equipment or cause injury to personnel.

- Pump and pipes are clear of welding flash or other debris.
- All pump head and mounting bolts are tight.
- All pipe connections are secure
- All guards, safety and protection devices, are in place and effective.
- Check the motor is wired for the correct direction of rotation (Figure 14 and Table 3 - Direction of flow)
- Flushing fluid, if required, is flowing. (See 3.11 SEALS AND FLUSHING)



ATTENTION

Do not use LU pumps to flush the system the first time. Flush the whole system with suitable cleaning agents before starting the pump, using another more suitable pump if necessary.

Be aware that heavy or metal debris tends to collect at the lowest point in the system.

- All valves are open - **NEVER** run the pump against a closed valve.
- Pipes and pump head, if heated, are to normal operating temperature.
- Pump is correctly lubricated. (See 3.13 LUBRICATION)

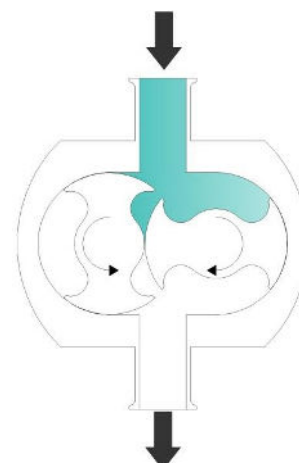

Figure 14 - Direction of rotation - viewed from pump head (Principle applies to all mounting orientations)

DIRECTION OF FLOW

	VIEWED FROM PUMP HEAD END	
DIRECTION OF DRIVE SHAFT	CLOCKWISE	ANTI-CLOCKWISE
HORIZONTAL PORTS TOP SHAFT DRIVE	LEFT TO RIGHT	RIGHT TO LEFT
HORIZONTAL PORTS BOTTOM SHAFT DRIVE	RIGHT TO LEFT	LEFT TO RIGHT
VERTICAL PORTS LEFT SHAFT DRIVE	BOTTOM TO TOP (UP)	TOP TO BOTTOM (DOWN)
VERTICAL PORTS RIGHT SHAFT DRIVE	TOP TO BOTTOM (DOWN)	BOTTOM TO TOP (UP)

Table 3 - Direction of flow

When possible, start the pump slowly and increase speed gradually.

- Listen for unexpected noises.
- Check for leaks.
- Check that the pump gives the desired flow rate, using the pumped media at normal operating speed.
- Do not continue to run the pump if the fluid is not flowing; dry running can damage seals.
(See 3.11 SEALS AND FLUSHING)



ATTENTION

- Observe the pump during the first few hours of operation - check for noises and excessive heating of pump, e.g. if above 80°C (176°F), unless pumping hot liquids when 110°C (230°F) may be reached.
- If operating at high speeds or with hot liquids, the surface of the pump can become hot.

4.2 DAILY CHECKS

- Visual checks of all seals for signs of leakage of product, flushing liquid (if used) and oil from the gearbox.
- Check the Packed gland seal for excessive leakage (if used)
- Listen for any unusual noises
- Check for any vibration or temperature changes.
- If minor problems are identified these

should be rectified at the end of the shift and if major they should be attended to at once.

4.3 WEEKLY CHECKS

- As Daily Checks.
- Remove the end cover of the pump and inspect for signs of damage or wear. Repair or replace if necessary.
- If the main product shaft seals are of the packed gland type, inspect them for signs of wear. Replace or plan for replacement as necessary.
- Check the lubrication level and top up if necessary. This must be done with the pump stopped.
- Check lubrication level on drive unit and top up as necessary. Follow the manufacturer's instructions.

4.4 MONTHLY CHECKS

- As Weekly Checks.
- Remove the end cover and inspect the surfaces.
- Visually check the rotor surfaces.
- If an end cover relief valve is fitted check its function. If the relief valve is not operating on a regular basis the diaphragm may have a tendency to stick.

4.5 SIX MONTHLY CHECKS

- As Monthly Checks.
- Change the end cover O-ring or end cover gasket.
- Remove the rotors for visual inspection and signs of wear.
- Inspect the seal faces for wear and the condition of the elastomers. Replace if necessary or note for planned maintenance.

4.6 ANNUAL CHECKS

- Change the mechanical seals if fitted, and if required.
- Replace the lip seal on the mechanical seal flush housings.
- Change the packing rings on the packed gland type shaft seals.
- Change all L-cups, O-rings and/or gaskets on pump head.
- Inspect gearbox oil seals and gear cover

gasket for signs of leakage and replace if necessary.

- Check bearing wear by seeing if there is any movement of the shaft side to side or forwards and backwards. If movement is perceived remove the gear cover and dismantle the bearings for inspection, replace if necessary.
- Drain and change the oil in the pump gearbox.

By ensuring a visual inspection daily and regular checks at planned intervals, pumps can be maintained to maximum performance for many years.

Failure to maintain the pump by carrying out the above checks may invalidate warranty.

5 CLEANING AND STERILISATION

LU pumps are designed for use with products that require the process equipment and pumps to be cleaned. The standard (level) of cleaning or sanitization required depends on the needs of the process and product. This information is provided for guidance only. It is the responsibility of the pump user to make sure that the cleaning protocol chosen is adequate to achieve the desired levels of cleanliness and JEC cannot accept any responsibility for contamination or loss.

In order to clean the pump it must either be dismantled (manual cleaning), or cleaned in place (CIP) as part of the procedure for cleaning the entire process. The higher the standard required, the more sophisticated the cleaning process. Pumps can be cleaned and sterilized in place, i.e. by flushing through with cleaning agents and/or steam, without the need to dismantle the pump.

Equally the pump can be quickly stripped to gain access to all fluid contact surfaces for manual cleaning or inspection if required.

5.1 CLEANING IN PLACE (CIP) & MANUAL CLEANING

Cleaning Systems

The type of cleaning system used depends partly on the level of cleaning required but also on what is to be removed.

Organic materials such as oils, fats, proteins need a different system to inorganic materials such as mineral salts.

Detergent manufacturers can give advice on the correct use of chemicals and temperature. CIP usually needs a velocity of 1.5 m/sec at 1 bar back pressure through the pipeline to achieve the turbulent flow required.

Procedure for Cleaning In Place (CIP)

Each pump is supplied in a generally clean condition but it is the responsibility of the user to establish suitable cleaning and sterilizing regimes appropriate to the fluid and process.

These should be implemented before the pump is first used and as often as required thereafter. The following guidelines will help with effective cleaning of HP & LH pumps to minimize risk of damage to the pump.

- Rinse through system with a suitable liquid, usually water at approximately 50°C (120°F), as soon as possible after completion of the process to remove bulk of residues before they dry onto surfaces.
- If CIP will not be carried out immediately after rinsing, leave the pump and system full of rinse liquid.
- Choose chemical cleaning agents to suit the nature of the contamination to be removed and use them in accordance with manufacturer's recommended dilution, temperature and circulation time but do not exceed 90°C (195°F). Confirm compatibility with pump materials of construction.
- CIP fluid flow should result in a mean pipeline velocity of at least 1.5 m/sec at 1 bar back pressure.

If using the lobe pump to circulate the CIP fluid, refer to the **Performance Data Sheet** for the pump speed to give the required flow, taking account of pressure losses through pipework. **NOTE**, that all pumps are more susceptible to cavitation when pumping hot liquids. Ensure adequate Net Inlet Pressure is available.

If using a separate pump to circulate CIP fluids, the lobe pump may need to be

rotated at a speed sufficiently high to allow the fluid to pass freely through. If sufficient pipe velocity cannot be achieved, fit a bypass loop to divert excess flow past the pump.

CIP fluid pressures must equal or exceed process pressure at all points in the system to ensure fluid reaches all contact surfaces. It may be necessary to restrict flow in the discharge pipework to achieve this but do not exceed differential pressure and temperatures shown on the pump **Performance Data Sheet**.

A minimum differential pressure of 1 bar is recommended for effective cleaning.

- After CIP, rinse through with neutralizers and clean water to remove all traces of cleaning agents.



ATTENTION

Do not pass cold liquid through the pump immediately after hot – allow temperature to change slowly. Failure to observe can result in pump seizure.

Procedure for Manual Cleaning

See elsewhere in this manual for procedures to dismantle and re-assemble the fluid contact parts.



ATTENTION

Take care not to scratch or damage pump parts. One part of the seal faces remains in the rotor when it is removed. Be extremely careful not to damage this seal face.

DO NOT use steel abrasive wool or brushes on fluid wetted surfaces as particles may become embedded in the surface and cause corrosion. Use suitable cleaning agents in accordance with their manufacturer’s instructions regarding temperatures, dilutions, skin contact precautions and other safety information.

Thoroughly clean all fluid contact surfaces and rinse as required.

As a minimum it will be necessary to remove the end cover and rotors. Re-assemble the pump in accordance with this manual.

5.2 STERILIZING IN PLACE (SIP)

It is possible to pass steam through the complete assembled system to sterilize the internal surfaces without dismantling the pump.

To achieve 100% sterility, it is important to steam through for a period long enough for the coldest part of the system to reach the correct temperature and hold for the time period required to kill off the organisms.

Procedure for Sterilizing In Place (SIP)

If using chemical sanitizers, follow the guidelines as for CIP above. If using steam, the pump specification must be chosen at the time of selection noting:

- EPDM elastomers offer best resistance to repeated steam contact but will need to be changed periodically.
- PTFE (Teflon) is least suitable for steam contact - PTFE end cover joints may need to be replaced every time the pump is sterilized.
- For more information contact JEC.

The pump should be mounted with the port axis vertical to avoid collecting liquid pools.

- Thoroughly clean the pump and process lines prior to sterilization.



ATTENTION

- Pass clean, wet steam through the system until all component temperatures have stabilized. Steam must be free of scale, rust and particles - a filter may be necessary. Typically steam will be at 121°C (250°F) and 1 bar (15 psi). Soak time, to bring the pump up to temperature is typically 20 minutes but this should be established, e.g. using thermocouples, as the required soak time will vary with individual installations.



ATTENTION

Do not rotate the lobe pump during this heating phase.



ATTENTION

Do not loosen or remove any pump components or pipe connections during steam sterilization as escaping steam may cause serious injury.

- Continue to pass wet steam through the lobe pump and process lines during the hold time. Hold time will be determined by the user to achieve desired level sterility. Typically this will be between 20 and 60 minutes.
- The lobe pump should not be rotated during this hold time unless absolutely essential to achieve sterility, due to increased risk of pump seizure. All pump components will normally reach the desired temperature by thermal conduction without rotating the pump.



ATTENTION

- If essential, the lobe pump can be rotated by hand during the hold time - beware of danger of hot surfaces – or at a maximum of 50 rpm but only if the pump is fitted with either:
- Single carbon/silicon carbide seals - or - Flushed or double seals provided a liquid flush, i.e. Condensate is connected and operating at a pressure above the steam pressure within the pump during SIP.



ATTENTION

If the lobe pump is fitted with single silicon carbide/silicon carbide seals it must not be rotated during hold time as the seal faces can bind together.

- At the end of the hold time, the pump must be allowed to cool naturally or can be purged with sterile air/inert gas.



ATTENTION

The pump must not be rotated during cooling.

- Do not allow cool liquid to enter the lobe pump before pump temperature has fallen to 60°C (140°F) or lower.

If the pump is fitted with silicon carbide/silicon carbide seals, flood it with liquid to lubricate the seals before rotating it.

6 INSPECTION AND

REPAIR

LU pumps need no adjustment during normal operation. It is advisable though to check oil levels and inspect pump head components (especially seals and joints) periodically so that they may be cleaned or replaced before they fail in service.

All primary fluid contact components of the pump can be inspected and serviced without removing the pump rotor case from the bearing carrier and without removing either the pump or drive unit from the baseplate, as follows:



ATTENTION - For your safety:

Before commencing any repair or inspection, isolate the power to the pump and drive motor, depressurize, drain and isolate the pipework, seal flush and temperature control jackets (if fitted).

6.1 END COVER

Removal

Before removing the end cover (122), ensure the pump & drive are isolated; the pump is cool enough to safely touch, drained of any fluids (take special care with hazardous fluids) and ensure that pump, seal flushing system and jackets are isolated and depressurized.

Proceed as follows:



ATTENTION

The end cover is heavy; take care to support it when removing the bolts (123).

- Remove the bolts (123) and remove the cover. If it is stuck tap carefully sideways with a soft hammer, do not lever off.
- **DO NOT damage** the face of the cover nor the seal ring: place face upwards on a clean surface.

Re-fitting

- To refit, reverse the procedure, ensuring the end cover is correctly located on the rotor case before tightening screws to the correct torque.

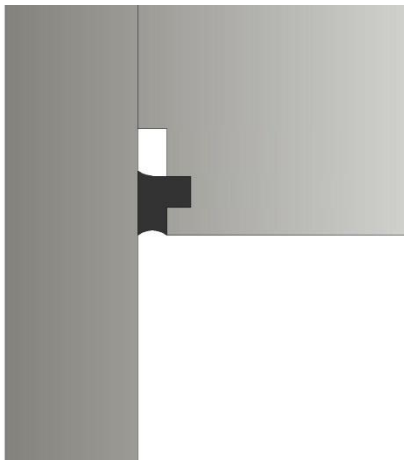

Figure 15 – Ultima end cover

- Press in, in 4 places first, see Figure 16, then press in the rest to avoid forming loops.

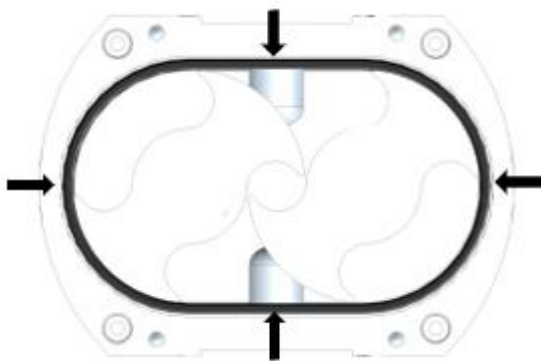

Figure 16 - Ultima end cover joint ring

6.2 ROTORS

Removal

The rotors in LU pumps are held in place with tie-rods (26 and 27) which have threaded ends and pass through the hollow shafts (24 and 25).

The tie rods are secured with nuts (87) and washers (88). To remove rotors proceed as follows:

Lock the pump rotors with a soft spacer - a plastic block (180) is provided for this purpose. See also figure 11. Loosen and remove tie-rod nuts (87) and washers (88).

Push the tie-rod (26 & 27) through the shaft to release the rotors (57) from the shafts (24 and 25). A soft mallet may be used on the end of the tie-rod, however care must be taken not to damage the thread.

Once the rotor and tie-rod are removed from the shaft the rotor (57) can be removed by unscrewing it from the tie rod (26 and 27) which should be held in a soft jaw vice. Ensure that the tie-rods are kept with the correct rotor and shaft.

Keep each rotor with its respective shaft to ensure correct mating of sealing faces on re-assembly - you may wish to mark or label the components at this stage.

Take care not to damage the rotors and especially the smooth face of the mechanical seal (80) which is pressed in the back. Do not attempt to remove the seal unless you intend to fit a new seal (80) or cup rubber (83).

Re-fitting

Ultima pumps - secure the tie-rod with the washer and nut. Lock the rotors using a soft spacer and tighten nut to the torque specified in table 4.

Pump Size	Fixings	Torque
LU 42/44	Tie-Rod	20Nm
LU 52/54	Tie-Rod	40Nm
LU 62/64	Tie-Rod	120Nm

Table 4 - Rotor torque

6.3 PRIMARY SEALS

When the rotors have been removed (see ROTORS) the primary seals can be inspected for wear, cracks, chips, scratches or signs of burning caused by running dry.

Inspect rubber joints for damage or deterioration. Clean the seal faces with soft lint-free tissue before re-assembly.

It is advisable to purchase and fit new elastomer trim kits from your local distributor, when removing and re-fitting seal faces. As a precaution it is also advisable to have a spare set of seal faces available as these parts are very brittle and are easily broken.

To dismantle mechanical seals:



ATTENTION



ATTENTION

Ensure that you DO NOT scratch any components of the pump, as this will compromise the cleanability of the pump.

- Carefully remove the static seal seats (80) from their bores in the rotor case (51), This is done by using the special seal removal tool (182) supplied with the pump. Carefully insert the seal removal tool between the outside diameter of the static seal seat and the bore in the rotor case. (Figure 17)

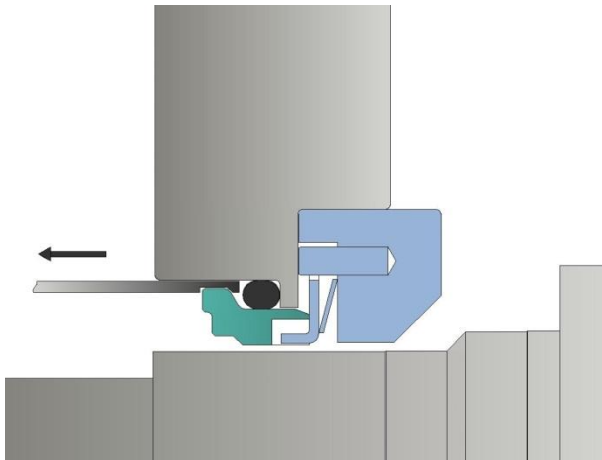

Figure 17- Seal seat removal

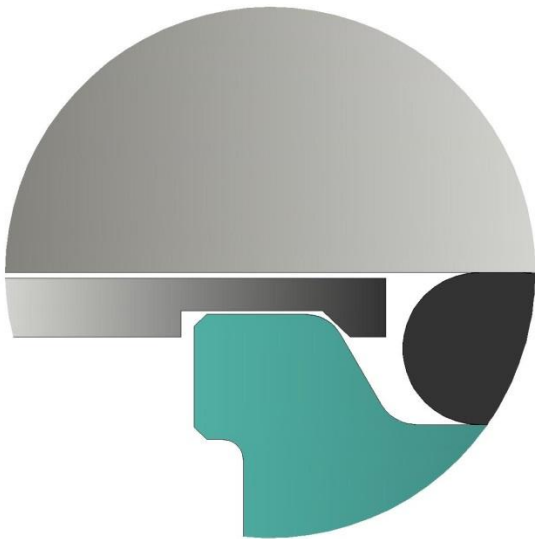

Figure 18 - Seal seat removal hooked end

- Push back the O-ring with the end of the tool and rotate the tool by 90 degrees, until the hooked end locks in position behind the seal seat. (Figure 17 & 18)
- Working the tool gently around the circumference of the seal, carefully pull the seal face out.
- Take great care not to scratch or damage the smooth face of the seal.
- Keep each seal with its respective shaft to ensure correct mating of the seal faces on re-assembly.
- The joint ring (83) may come out with the seal

face. If not, then remove it from the rotor case bore and keep it together with the seal face.

- You may wish to label the components.

Note: static seal seats can also be accessed from the back of the rotor case after removing the rotor case and seal housings (see 6.6 SEAL HOUSINGS).

- Only remove the rotary seal seat (80) from the back of the rotor (56) if you intend to fit a new seal or L cup rubber (83). Gently prize out the seat from the rotor using two soft levers to avoid scratching rotor and damaging seal face. (Figure 19).

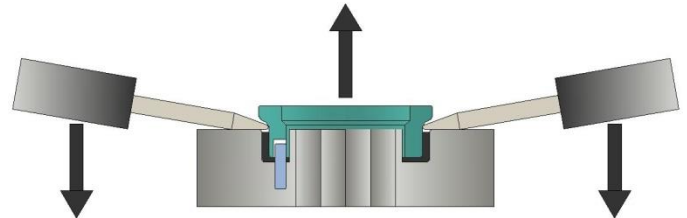

Figure 19 - Seal removal from rotor

Fitting Mechanical Seals:



ATTENTION

Fit the seal face with the narrow face track into the rotor case. The seal face with the wide face track should be fitted into the rotor.

- Fit the O-ring (83) to the static primary seal face and lubricate the bore in the rotor case with a suitable lubricant compatible with the pumped fluid and the elastomer.
- DO NOT** use mineral-oil based lubricants on EPDM joints.
- Align slots in the seal face with tabs of drive plate in the seal housing; a small cut-out is provided so one drive tab can be seen (Figure 20).

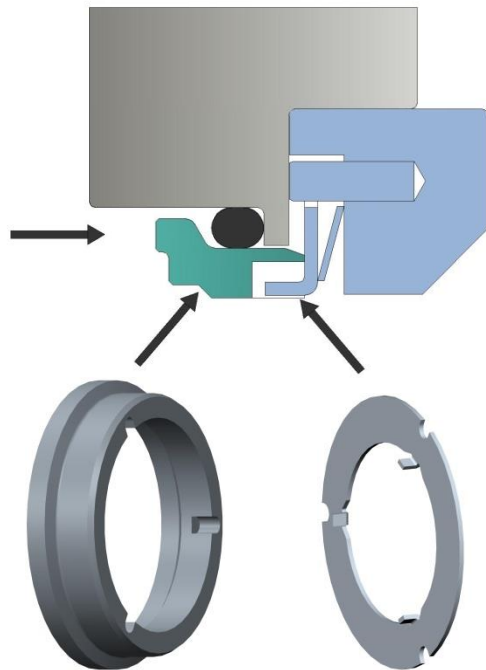

Figure 20 - Fitting stationary seat

- Push each seal seat in straight; when correctly fitted, seal seats should slide freely against the resistance of their springs.

Undue pressure is not required or recommended as seals are precision components. Be sure not to damage the O-ring (83), if difficulty is experienced put the O-ring into the rotor case bore then push the seal seat into the bore.

Note: if the rotor case has been removed (see 6.7 ROTOR CASE), static seal seats should be inserted into the rotor case, before mounting on to bearing housing.

- To fit the seal seat to the rotor (56), first insert L cup rubber (83) into the rotor (DO NOT lubricate), ensure alignment with the drive pin. (Figure 21).

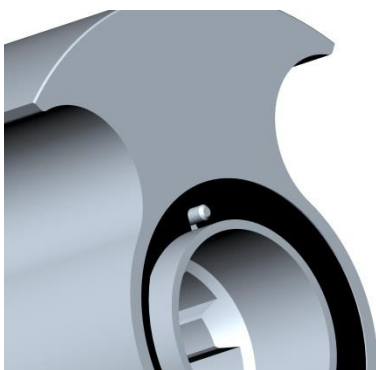

Figure 21 – Align the L cup to the rotor drive pin

- If the PTFE trim is fitted, insert the rubber washer first followed by the PTFE sleeve. Note that the sleeve is slightly tapered and will be

easier to fit if the narrow side is inserted first. Then lubricate the outside diameter of the seal seat.

- Align the rotor drive pin with one of the three slots in seal seat.
- Engage the leading edge of the seal seat into the cup rubber or PTFE sleeve. Push down evenly until the seal seat rests squarely on the bottom of the seal bore in the rotor.
- **DO NOT** damage the seal face.
- When correctly fitted, the seat is parallel with the back face of the rotor and must not be tilted. Any “run-out” of the seat will cause leakage of the seal.
- Assembly of the seal is now complete.
- Carefully clean all the seal faces with a soft lint free cloth and to remove all dust and grease.
- It may be necessary to use a compatible solvent to remove oil or grease.
- It is not normally necessary to remove the seal housings (86) from the back of the rotor case except to check the condition of the springs (82) and drive plates (81).
- If re-fitting the seal housings, align the 3 slots in outer edge of drive plate with the 3 pins. When fitted, ensure the drive plate can slide freely against the spring pressure. (see 6.6 SEAL HOUSINGS)

6.4 MECHANICAL SHAFT SEALS - SINGLE FLUSHED

Pumps fitted with flushed seals have lip seals fitted in order to retain a flushing or barrier fluid.

To service lip seals it is necessary to remove the rotor case (51) (6.7 ROTOR CASE)

Removal:

- Remove the seal housings (89) from the back of the rotor case. (see 6.6 SEAL HOUSINGS).
- Press the lip seals out of the housings.
- Check that the surface of the shaft where the lip seal runs is smooth and is not grooved.

Re-Fitting:

- Push the new lip seals into the housings. Assemble the spacer collar, wave spring and drive plate as shown in Figure 22. (Also see 6.6 SEAL HOUSINGS)

- When re-fitting the seal housings, align the 3 slots in the outer edge of the drive plate with the 3 pins. When fitted, ensure the drive plate can slide freely against the spring pressure.
- You may wish to insert the O-ring (83a) and static primary seal seats at this point (see 6.3 PRIMARY SEALS).
- When re-fitting the rotor case to the bearing housing, take care that the lip seals and mechanical seals (80) are not damaged by the shaft splines or shaft ends.

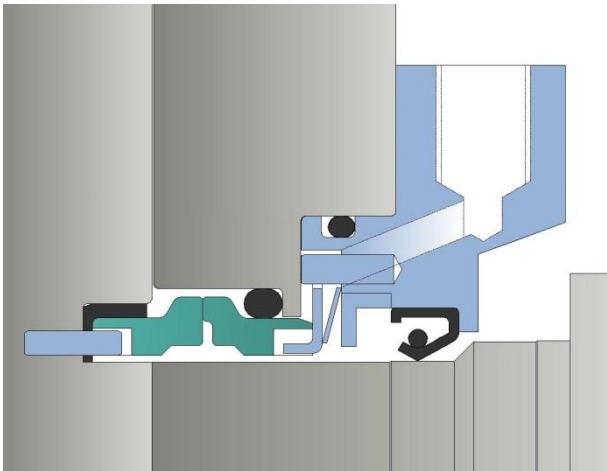

Figure 22 - Single flushed mechanical seal

6.5 MECHANICAL SEALS – DOUBLE

(Refer to 6.3 PRIMARY SEALS - for servicing of primary Seals.)

Pumps fitted with double seals have secondary seals in order to retain a flushing or barrier fluid. To service primary seals refer to 6.03 Primary Seals. To service secondary seals it is necessary to remove the rotor case (6.7 ROTOR CASE).

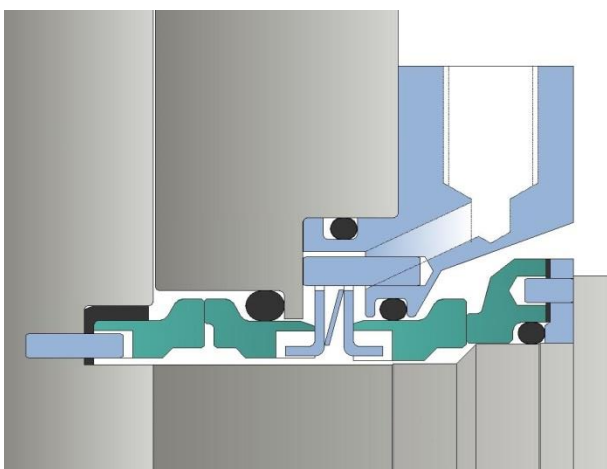

Figure 23 - Double mechanical seal

Removal:

- Remove the static faces from the housings. (95)
- If fitting new O-rings (93) prize them out of the housing (95).
- Pull the rotary seats (92) off of their shafts. Take care not to scratch or damage the smooth faces of the seals. Keep each seal with its respective shaft to ensure correct mating of the seal faces on re-assembly – you may wish to label the components at this stage.
- If fitting new O-rings (93) prize those out of their seal face (92). It is not normally necessary to remove the seal housings (95) from the back of the rotor case except to check condition of springs (82) and drive plates (81) (See 6.6 SEAL HOUSINGS).

Re-Fitting:

- To re-assemble, place the O-ring (93) in the double seal housing (95), lubricate the outside of the static seat with a suitable lubricant compatible with the barrier fluid. Align the slots in the seal face with tabs of drive plate (94) in the seal housing, (Figure) and push the seat fully in. The seat should slide freely against the plate (94) and wave spring (82).
- If fitting double seals to a pump for the first time, e.g. retrofitting a single seal pump, gently tap or press the support ring (92b) square up against the shoulder on each shaft.
- Fit the soft washer (92a) in place on the support ring.
- Fit the O-ring (93) to the rotary seal seat (92). Gently push the seal seat squarely on to the shaft, aligning the hole in the rear of the seal face with the pin on the support ring.
- Clean the seal faces with a soft lint-free tissue to remove any grease or dust - do not lubricate. Refit the rotor case taking care that the shafts do not damage secondary seal faces. (6.7 ROTOR CASE)

6.6 SEAL HOUSINGS

It is not normally necessary to remove the seal housings (86, 89 or 95) from the back of the rotor case except to check the condition of the springs (82) and drive plates (81).

If required to do so, proceed as follows:

Note: Seal housings vary for single (86) flushed (89) & double seals (95) (see 3.11 SEALS AND FLUSHING).

Removal:

- Remove the end cover (see 6.1 END COVER), rotors (see ROTORS), rotor case (6.7 ROTOR CASE).
- Position the rotor case (51) face down on the clean smooth surface, seal housings (86, 89 or 95) uppermost. Taking care not to damage the front of the rotor case.
- If double seals are fitted remove the static seal seats (92) from the housings (95), keeping mating seal faces together. You may wish to label the components. (6.5 MECHANICAL SEALS – DOUBLE).
- Loosen the screws (85) by half a turn and rotate eccentric clamp plate (84) by half turn.
- Carefully withdraw the seal housings. Note the position of the drive plates, wave springs and backing rings.
- Inspect the components for wear, replace as required.

Re-Fitting:

For single flushed seal housings refer to (6.4 MECHANICAL SHAFT SEALS - SINGLE FLUSHED) for lip seal replacement.

- **Primary or Single Flushed Seal** - Assemble the wave spring (82) followed by the drive plate (81). Ensure that the 3 slots on the outer edge of the drive plate locate on the 3 pins in the housing. Drive plate should be assembled with drive tabs side last.
- **Secondary Mechanical Seal** - Assemble one drive plate (94) with drive tabs side entering first and the 3 slots on the outer edge locating on the 3 pins in the housing. Assemble the wave spring (82) followed by the second drive plate (81).
- Ensure that the 3 slots on the outer edge of the drive plate locate on the 3 pins in the housing. The drive plate should be assembled with drive tabs side last i.e. opposing direction to first drive plate.
- For flushed or double seals, position O-ring (91) on to the step on the outside diameter of the seal housing.
- Holding the seal housing (86), drive plate(s) (81 & 94) and wave spring (82), together; position the housing assembly into the bore on the backside of the rotor case. Fit it flat with the rear face of the rotor case.
- Hold in position and rotate the clamp plates (84)

half a turn in order to retain the housing. Tighten the screws (85) finger tight only.

- Ensure the drive plate(s) is free to move.
- Tighten the housing screws to a torque of 15Nm.

6.7 ROTOR CASE

- Disconnect the process pipes and any flush/barrier connections; first ensuring fluid is not under pressure.
- The rotor case can be removed after withdrawing the end cover (see 6.1 END COVER), the rotors (see, ROTORS)
- Remove four hexagon socket screws (52) holding the rotor case (51) to the bearing carrier (1).

Note that the rotor case is dowelled and can only be re-fitted one way round.



ATTENTION

Secure the pump onto a workbench or baseplate before removing the rotor case, as the gearbox will tip backwards without the rotor case being in position.



ATTENTION

The rotor case is heavy; ensure that it is supported before the four hexagon socket screws are removed.

If primary or secondary static seal seats (80) are still fitted to the rotor case take care not to damage them on the shaft ends (24 & 25). If single flushed seals are fitted take care not to damage them on the shaft splines or shims (30).

Re-fitting:

- Refit any seal housings removed (6.6 SEAL HOUSINGS) to the rotor case.
- Refit the rotor case (noting dowel for rotation) and torque the four hexagon head socket screws (52) to the torque specified in Table 5 – Rotor case torque table.

Pump Size	Fixing	Torque Nm
LU 42/44	Rotor case Bolt	10
LU 52/54	Rotor case Bolt	20
LU 62/64	Rotor case Bolt	20

Table 5 – Rotor case torque table

6.8 ROTOR CLEARANCE - CHECKING & ADJUSTMENT

LU pumps have very small, carefully controlled clearances between rotors and rotor case. Scimitar meshing clearances and Radial clearances (shown a & b) are factory set and cannot be changed. Axial clearances (shown c) are adjustable if incorrect. (Figure 24, 25 & Table 6).

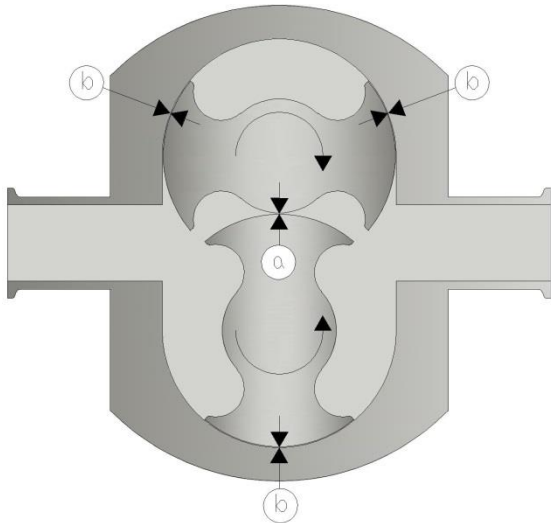

Figure 24 - clearance measuring

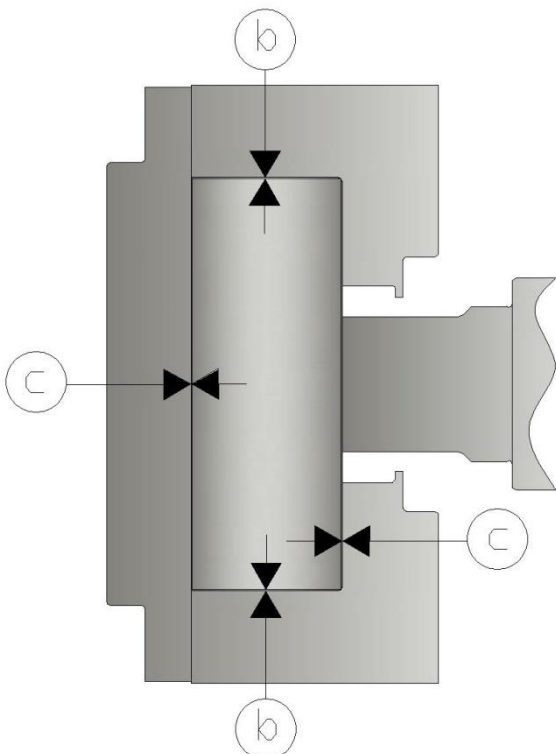

Figure 25 - Shim / clearance measuring

Pump model	Rotor code	Front: rotor to front cover	Radial: rotor to rotor case
LU42	SCHE	0,075	0,075
	SCHP	0,13	0,21
LU44			
	SCHP	0,13	0,21
LU52			
	SCHE	0,125	0,125
	SCHP	0,17	0,25
LU54			
	SCHP	0,15	0,25
LU62			
	SCHE	0,15	0,2
	SCHP	0,25	0,45
LU64			
	SCHP	0,25	0,45

Table 6 - Rotor clearances (all values in mm)

Axial Clearance: Scimitar and Tri Lobe

- With the pump assembled, the end cover (122) removed (see 6.1 END COVER), and the rotors (56) (see ROTORS) and rotor case (1) (6.7 ROTOR CASE) fully secured to the correct torques.
- Measure the rotor front end clearances (c) using a depth gauge or feeler gauge and straight edge.
- If the clearance is incorrect (to Table 6 – Rotor clearances) remove the rotors (56) (see ROTORS).
- Remove the O-rings (31) and shims (30), the shims are cut to allow them to slide over the shaft.
- If mechanical shaft seals are fitted take great care not to scratch, chip or damage the seal faces.
- Measure the thickness of the shim pack for each shaft and calculate the thickness of the shim to add or remove on each shaft to give the front clearance specified in Table 6 – Rotor Clearances.
- Shims are available in increments of 0.025 mm (0.001 inch).
- To fit the shims open them slightly and slide onto the shaft up to the shoulder (A) (Figure 26).

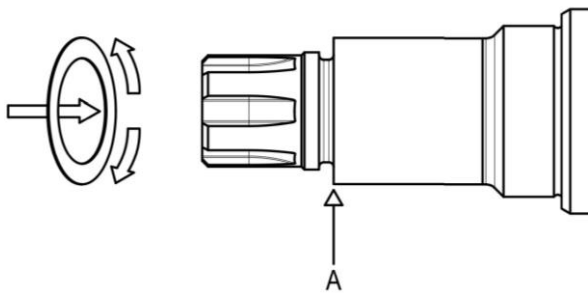

Figure 26 - Fitting shims

Note: New shims are not cut; this will need to be done with scissors prior to fitment if required.

- Fit the shims and retain them with the O-ring (31).
- Refit the rotors and tighten the retaining bolts (59) to the correct torque (see ROTORS). Re-check end clearance and re-adjust if necessary.

Check the condition of the bearings and the pre-load if any side-to-side movement of the rotors can be detected or if the radial clearance is incorrect.

There is no adjustment for radial clearance - replace the shafts and/or bearings if worn.

6.9 THERMAL JACKET – END COVER

Refer to chapter 8 EXPLODED DIAGRAMS

Ensure that the liquid feed to the jacket is switched off before attempting to service it.

- Dismantle the jacket (144) from the cover (143) by removing the screw (147) from the centre of the jacket
- Remove the inner O-ring (146) from the groove around the screw and the outer O-ring (145) from the groove around the outside edge of the jacket.
- Replace the O-rings and re-fit the jacket.
- Tighten the screws to a torque of 15Nm.

6.10 THERMAL JACKET – PUMP HEAD

Refer to chapter 8 EXPLODED DIAGRAMS

Ensure that the liquid feed to the jackets is

switched off before attempting to service them.

- Dismantle the two jackets (139) from the end cover (138) by removing the screws (141).
- Remove the O-rings (140) from their grooves.
- Replace the O-rings and re-fit the jackets.
- Tighten the screws to a torque of 15Nm.

6.11 Bearing housing - inspection & repair

Power input to the pump is via the drive shaft (24). The gearbox has two contra-rotating shafts (24 & 25), supported by taper roller bearings (4 & 5). The shafts are synchronized by a pair of precision cut gears (6) that distribute power between the drive shaft (24) and driven (lay) shafts (25).

LU pump gearboxes have been designed for easy inspection and maintenance.

Inspection:

Bearing housing (1) and gearbox internals can be inspected by removal of the gear cover (11).

- Disconnect the pump from the drive and remove the shaft coupling.
- Drain the lubricating oil from the pump gearbox via the drain plug (14).
- Remove two gear cover securing screws (18) and plastic sealing washers (19).
- Remove the drive shaft key (29) and gear cover (11), taking care not to damage the drive shaft oil seal on the drive shaft key-way.

Preliminary inspection can now be carried out without further dismantling; i.e. condition of timing gears or movement in the bearings.

- If all is found to be satisfactory, refit in reverse order.

Repair:

To repair the bearing housing assembly you will need the parts contained within the appropriate Repair Kit, in addition to any new gears (6) or bearings (4 & 5) required. Contact your distributor for details.

6.12 GEARBOX SHAFTS, GEARS AND BEARINGS

If the shafts are to be removed for any reason, label all components including bearing outer races, shims etc. and keep in their correct positions.

With the pump disconnected from its drive.

- Remove the rotor case (see 6.7 ROTOR CASE), drain oil via the plug (14) and remove the gear cover (11).
- Bend down the tab washers (7) which lock the gear nuts (8).
- Before loosening the gear nuts (8) lock the rotors on the shaft using the plastic block supplied for this purpose. Loosen the gear nuts (8) using a C-spanner.
- Remove the gear nuts (8), tab washers (7), timing gears (6) and drive shaft keys (28), from the shafts.

Note: The aluminium and stainless steel components of the Ultima bearing carrier are machined as an assembly and should never be dismantled.

- Using a light press or soft hammer, drive out the shafts (24 & 25) towards the front (rotor case end) of the bearing housing (1) (Figure 27). This will push out the front oil seals (23).

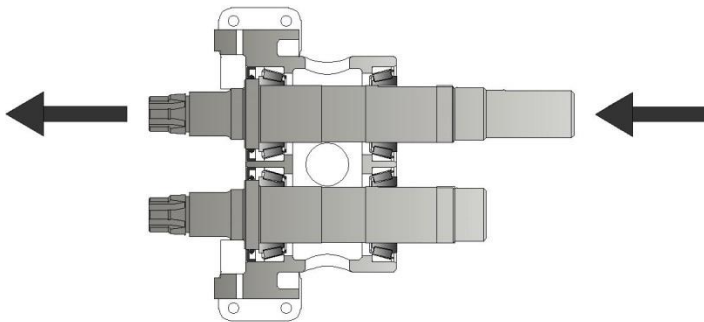

Figure 27 - Removing shafts

The inner race of the rear bearing (4) will slide off the shaft. Be careful that it does not fall off. Alternatively, prize out the front lip seals (23) first with a sharp tool. Take care not to damage the bearing housing or journals of the shaft during this operation.



Stainless steel bearing housing option only: The aluminum and stainless steel components of the bearing carriers are machined as an assembly and should never be dismantled.

- The outer races of the bearings (4 & 5) can be pulled out of the housing (1).
- To remove the inner race of the front bearing a press will be required.

Re-Fitting:

Assemble in the reverse order, checking and re-adjusting the bearing pre-loads.

(6.13 BEARING SET-UP AND PRE-LOAD)

6.13 BEARING SET-UP AND PRE-LOAD

Each shaft is supported on 2 taper-roller bearings front (5) and rear (4) which are preloaded to prevent any end-float (sideways movement) of the shafts (24 & 25).

If any movement is detected in either shaft (side to side or axially) new bearings must be fitted (6.12 GEARBOX SHAFTS, GEARS AND BEARINGS) and correctly pre-loaded.

Assembly of the shafts is as follows:



SAFETY: Bearings inner races require heating to 140°C (230°F). Protective gloves are essential.



ATTENTION

- **USE GLOVES:** Heat only inner races of front bearings (5) and assemble onto the shafts (24 & 25) making sure they are square and pressed tight against the shaft shoulder, ensure bearings are in the correct orientation. (Figure 0)

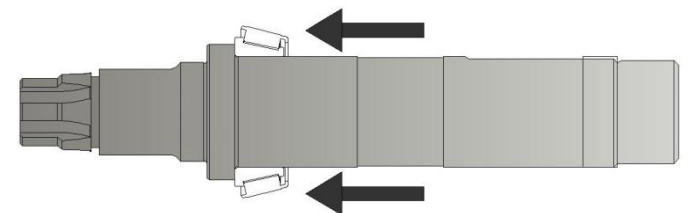

Figure 28 - Inner-ring fitment

- Press both front (5) and rear (4) outer races into the bearing housing, (Figure 31) making sure they are square and pressed tight against the bearing housing shoulder.

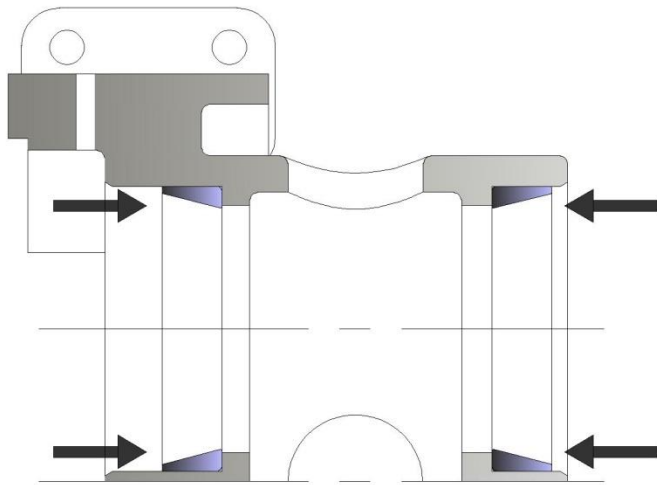

Figure 29 - Outer-ring fitment

NOTE: At this stage **DO NOT** put additional oil on bearings.

- Stand shafts (24 & 25) on their front face and lift the front of the bearing housing (1) over them sliding the inner races of front bearings (4) onto the shafts until the front inner bearing races are in light contact with their outer races.



ATTENTION

- USE GLOVES: Heat inner races of rear bearings (4) and assemble onto the shafts (24 & 25) making sure they are square and pressed tight against the outer races in the bearing housing. Ensure bearings are in the correct orientation.
- Put the bearing housing assembly (with shafts in position) onto its feet.
- Fit the gear drive key (28), gear (6), tab washer (7) and gear nut (8).
- Tighten the gear nut (8) by hand to hold the assembly in place, taking-up any end float.

Note: To stop the shafts spinning the rotors can be attached to the front of the shafts so a plastic block can be placed between them as if you were tightening the rotor screws. Alternatively a plastic block can be inserted between the gears to stop the rotors turning.

- Rotate the shaft a minimum of 4 times and tighten the gear nut (8) again by hand.
- Rotate the shaft a further 4 times, tighten the gear nut again by hand and then tighten the nut a further quarter turn, using the C-Spanner.
- Rotate the shaft 4 more times and torque the gear nut (8)
- Repeat two-three times until no further

tightening of the gear nut is perceived.

Pump Model	Gear nut Torque Nm
LU 42	50
LU 44	50
LU 52	100
LU 54	100
LU 62	150
LU 64	150

Table 7 - Gear nut torque settings

NOTE: when fitting the second gear, align gear timing marks. (Figure 30)

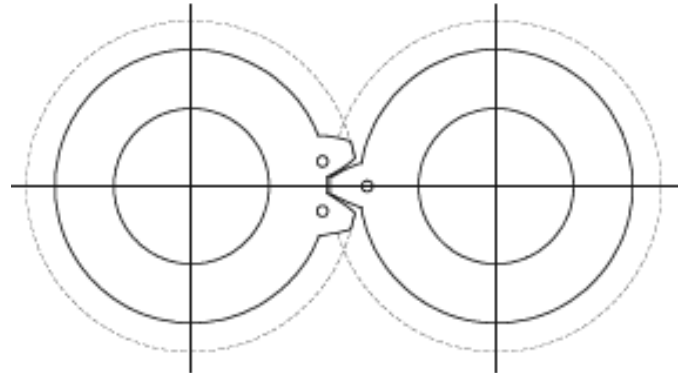

Figure 30 - Gear timing marks

Once the Shaft, Bearing and Gear Nut assembly is complete the bearing housing can be rebuilt as follows:

- Front oil seals (23) should be pressed in, until they are flush with the front face of the bearing housing (1). Take care not to curl/damage the lip or displace the gaiter spring on the shaft.
- Ensure they are square to the shaft (not tilted).
- Assemble the gear cover (11) to the bearing housing (1), using the new gasket (9), new rear oil seals (20) and gear cover screw seals (19). Be careful not to damage the lip seal on the drive shaft keyway. Tighten the gear cover screws to the torque shown in Table 1 (3.3 LOCATION & ORIENTATION)
- Ensure the vent plug (12) is at the highest point, the sight glass (13) on the side of the cover and the oil drain outlet at the lowest point and sealed with suitable thread sealant.
- Re-fit the seal housings if removed, rotor case, seals, rotors and end cover as described in section 6. Remember to check the rotor clearances (6.8 ROTOR CLEARANCE - CHECKING & ADJUSTMENT).
- Fill the gearbox with the correct grade and quantity of oil. (3.13 LUBRICATION)
- This should be to the centre of the sight glass

- (13).
- Some oil may be retained in the sight glass and will give a false impression of the oil level. Be sure that the sight glass is full of oil to its centre.

	Temperature	of Processed Fluid
T1	450°C	N/A
T2	300°C	N/A
T3	200°C	140°C
T4	135°C	85°C

Table 8 - Temperature class

LU Rotary Lobe Pumps are limited to a processed fluid temperature of maximum 140°C.

Seal Flushing

To prevent the potential risk of hot surfaces on the pump seals it is essential to apply additional cooling and lubrication of the seal faces through the use on an additional auxiliary support system as described 3.11 SEALS AND FLUSHING.

In addition to the system requirements described in 3.11 SEALS AND FLUSHING, controls must be implemented to ensure the continuous and uninterrupted operation of the flushing circuit during pump operation.

It is essential to ensure that all the air/gas is purged from the seal housings so that the seals are fully immersed in the quench/barrier fluid.

7 ATEX APPLICATIONS

General

This supplement applies to the LU Rotary Lobe Pumps used in applications covered by the ATEX Directive 2014/34/EC.

Protection Class



II 2 GD c Tx¹

¹ Temperature class depending upon the processes media refers to section 'Maximum Surface Temperature' in below text.

Safety Zones Applicable

Zone 1, 2, 21 & 22

The baseplate of the pump must be earthed in order to prevent a build-up of static electricity.

Maximum Surface Temperature



ATTENTION

The maximum surface temperature of the LU is dependent upon the temperature of the media processed by the pump.

The table shows the maximum permitted temperature of the processed fluid within the pump in order to ensure that the maximum surface temperature of components does not exceed the corresponding temperature class.

Temperature Class	Maximum Surface	Maximum Temperature
-------------------	-----------------	---------------------

8 EXPLODED DIAGRAMS

8.1 Ultima Exploded Diagram

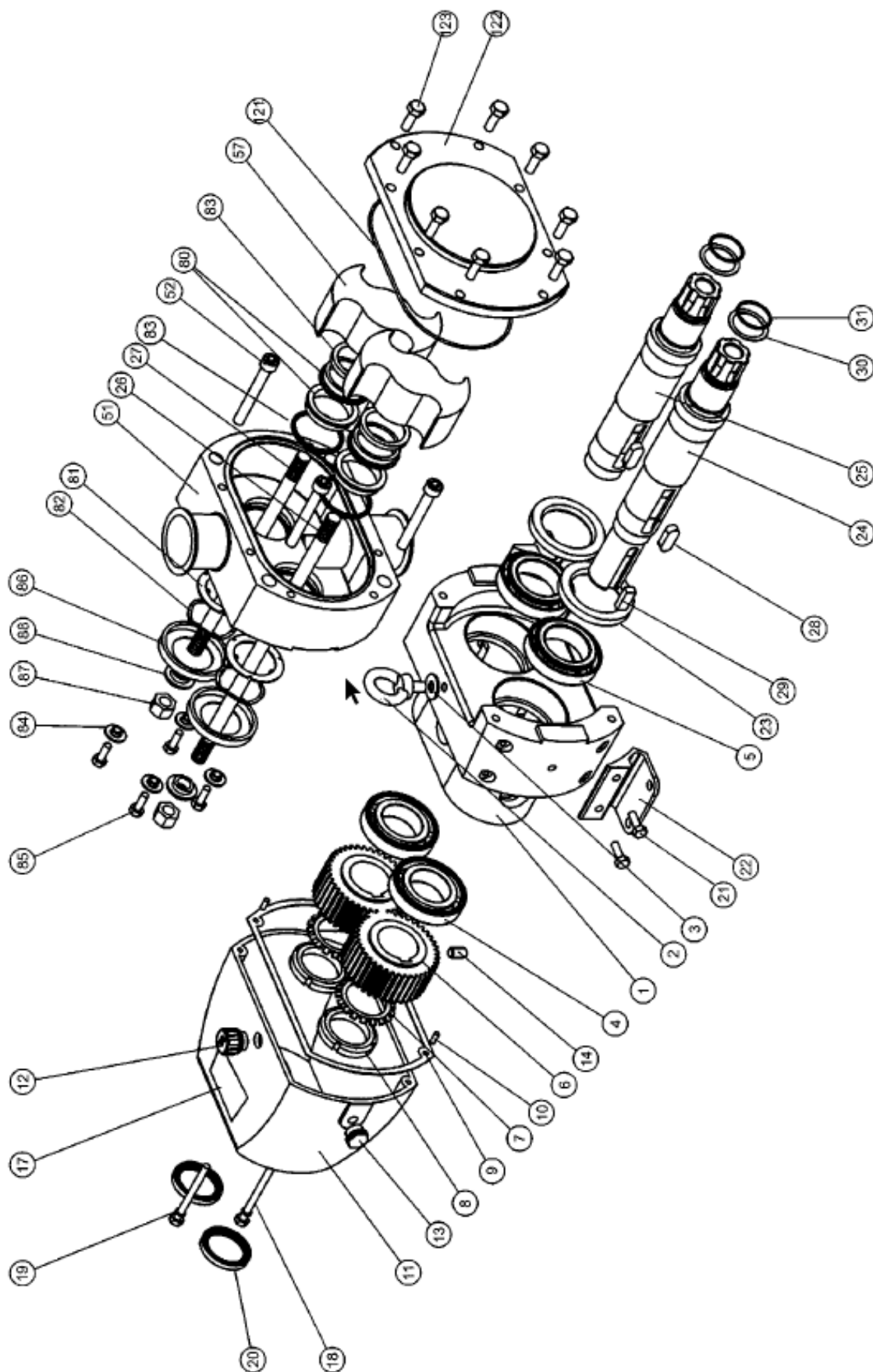

8.2 Options & Extras - Sectional Views

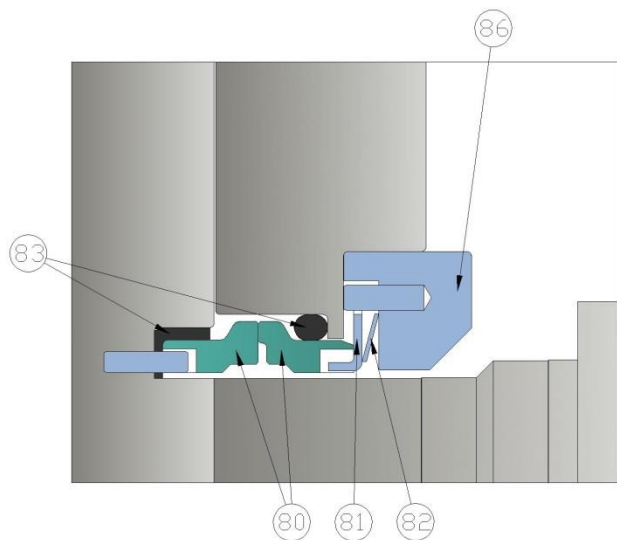

LU Single Mechanical Seal

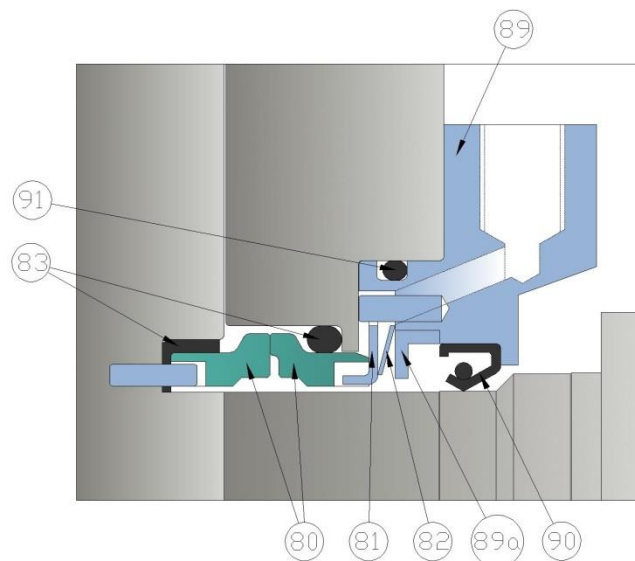

LU Flushed Mechanical Seal

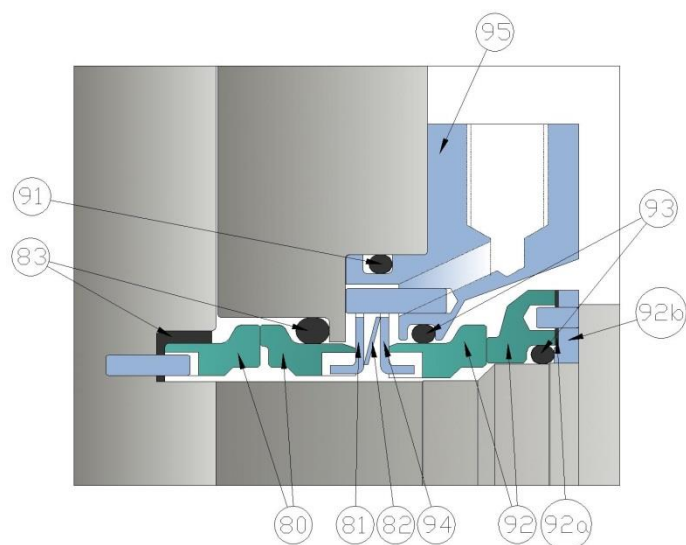

LU Double Mechanical Seal

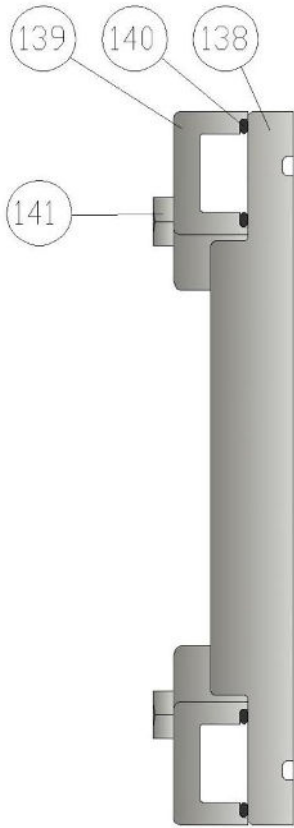

LU Thermal Jacket – Pump Head

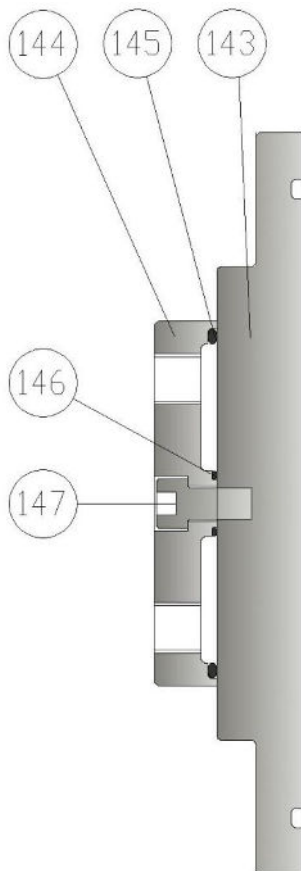

LU Thermal Jacket – End Cover

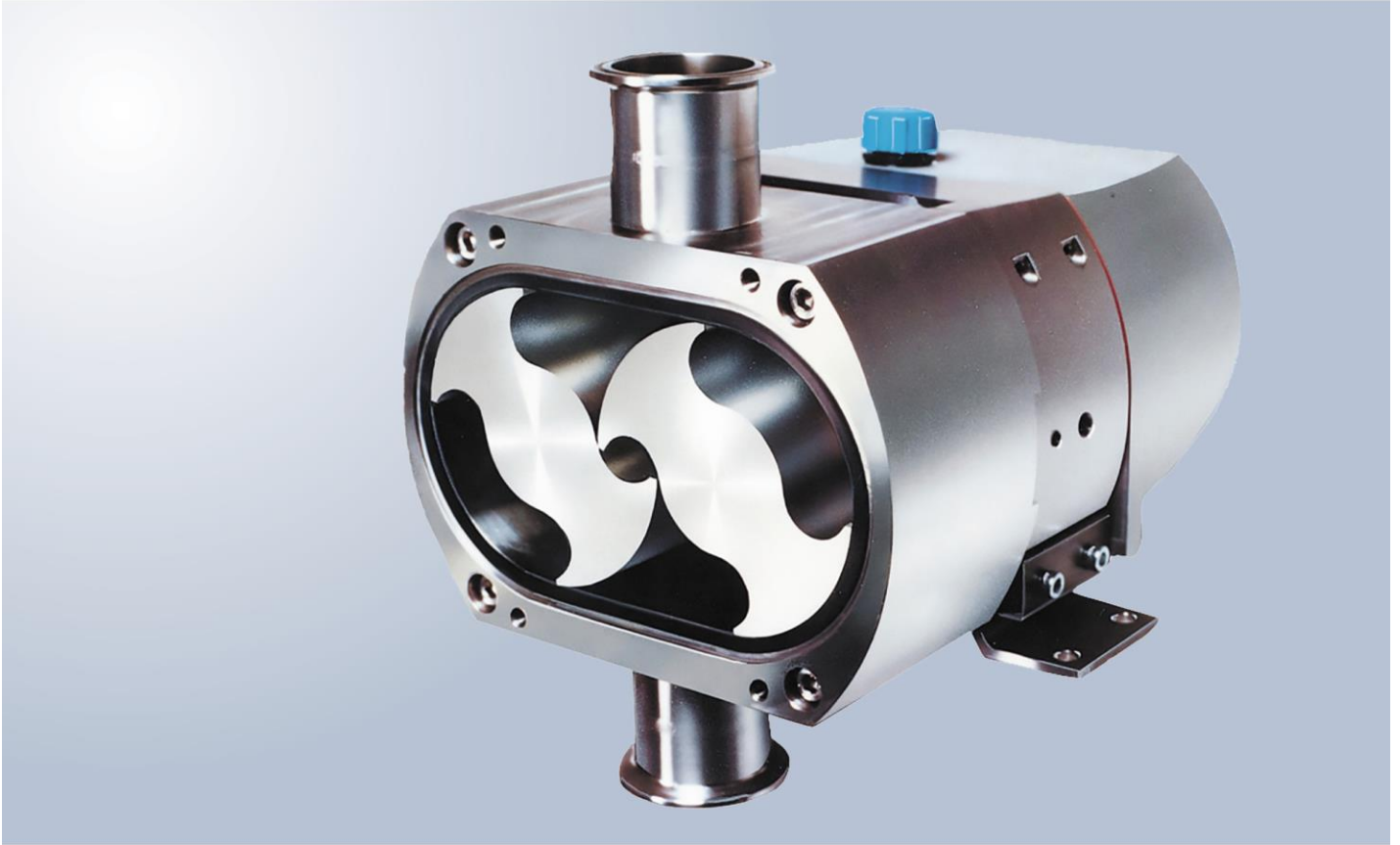

Packo-Manual-LU-series-2023-int(en)

VERDER
passion for pumps

JEC LTD.

15-26, Beodeul-ro 1362,
Paltan-myun, Hwaseong-si,
Gyeonggi-do,
18578, Rep. of Korea

MAIL export.kr@jec.verder.com
WEB www.jecpump.com

AUSTRIA / BELGIUM / BULGARIA / CHINA / CZECH REPUBLIC / FRANCE
GERMANY / HUNGARY / INDIA / ITALY / THE NETHERLANDS / POLAND
REPUBLIC OF KOREA / ROMANIA / SLOVAKIA / SOUTH AFRICA
SWITZERLAND / UNITED KINGDOM / UNITED STATES OF AMERICA