

Add-on module of the WANGEN Twin NG,
with hopper and screw conveyor

WANGEN VarioTwin NG

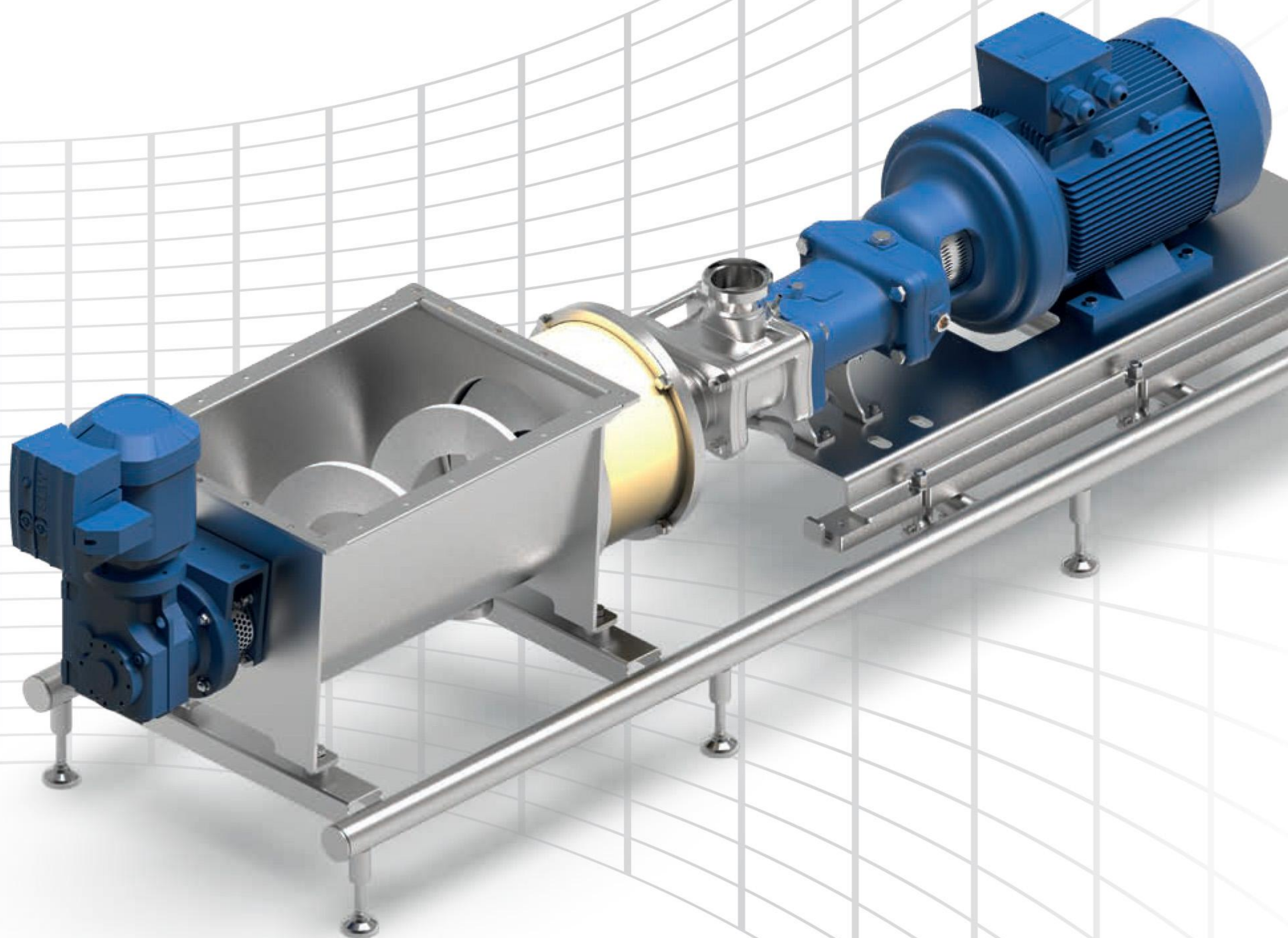

Gently feeding high-viscosity media:
The hygienic and patented add-on
to the WANGEN Twin screw pump.

WANGEN VarioTwin NG

The VarioTwin is the ideal feeder unit to pump highly viscous, not flowable media for the series 104 and 130 of the WANGEN Twin NG. This is due to the forced conveying of the pumped media via the feed screw. To cover the widest possible range of applications, the length of the hopper can optionally be designed at various levels. Therefore, the name VarioTwin was chosen.

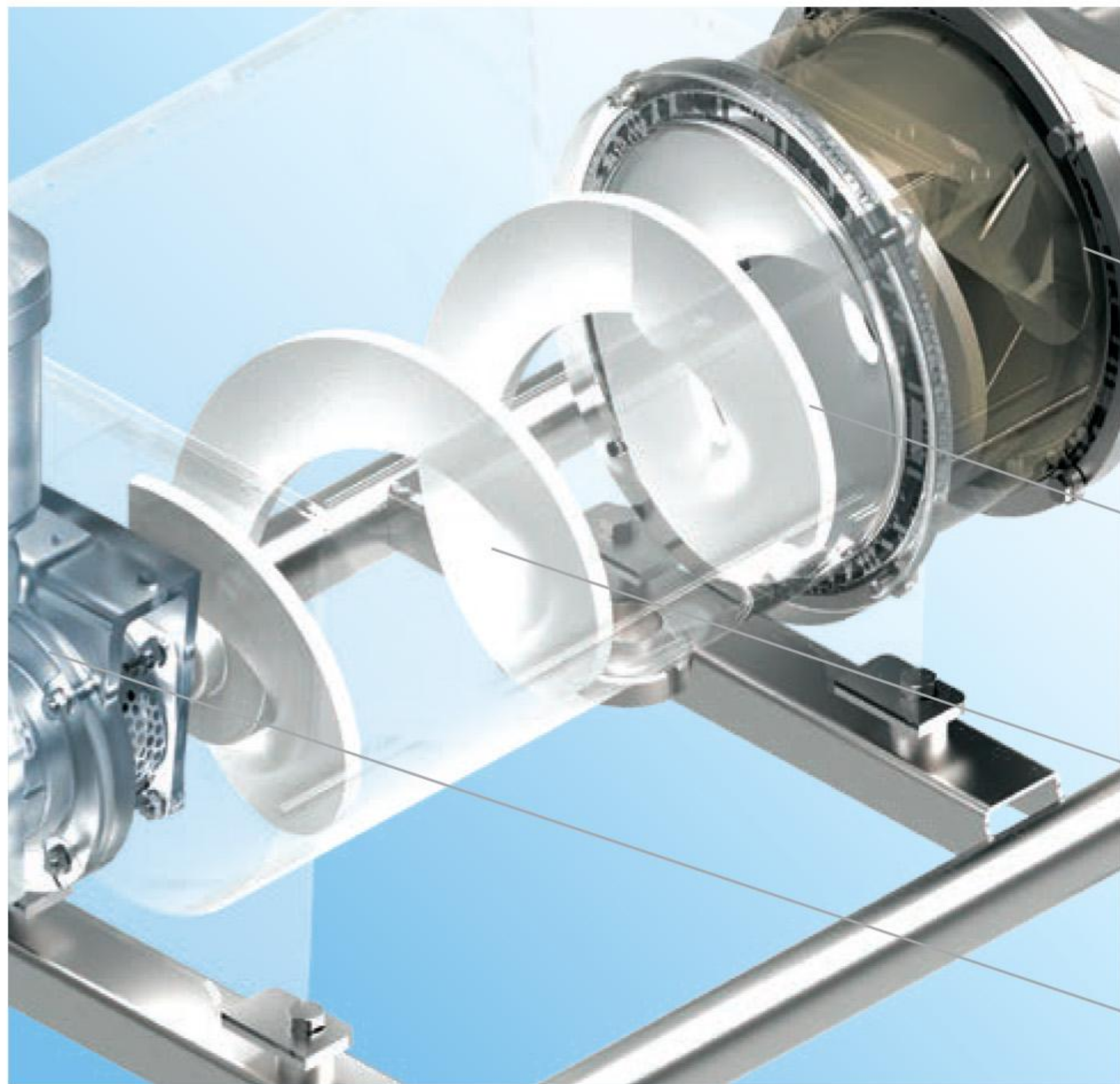

S-cone adapter element. Connects the feed unit with the WANGEN Twin. Suitable sizes for the Twin NG 104 and 130.

'Coreless' screw conveyor. Is able to return excess material. Particularly gentle feed. Simple, effective cleaning.

Hopper available in variable length, optimally balanced to meet the field of application and requirements.

Drive of feed screw in the hopper can be regulated separately.

Cross-section of the 'VarioTwin NG' hopper.

Product advantages:

- 'Coreless screw' for gentle product treatment of media.
- Hygiene-optimised design; therefore, minimal dead spaces. Enables easy and efficient cleaning.
- Cantilevered support system of the screw for maximum hygiene with minimal residues
- Low space requirement due to compact design.
- Drive independently controlled pump speed.
- Low energy consumption due to energy-efficient screw geometry.
- Materials are FDA-compliant, product-contacting parts in 1.4571/1.4404.

Technical highlights:

- Flowrate up to 10 m³/h
- Temperature up to +90 °C
- Viscosity up to 3.000.000 mPa·s



Applications

Conveying Materials

The WANGEN VarioTwin NG is suitable for pumping the following media:

- High-viscosity dough in the baking industry
- Fruit, such as strawberries, including frozen fruit
- Vegetables, such as potatoes
- High-viscosity chocolate mixture, waffle rework, marzipan and sugar mixtures (licorice, etc.)
- High-viscosity dairy products, such as curd
- Pulp-containing media, such as additives in food production
- High-viscosity soy products (okara)
- Meat-based products, such as raw mixture of reconstituted meat, minced meat, sausage meat or animal feed
- Fibre-containing extracts for the cosmetics industry (cream, ointment or soap)
- High-viscosity chemical products, such as anti-freezing agents, glues (including wood glue) or raw materials and pastes

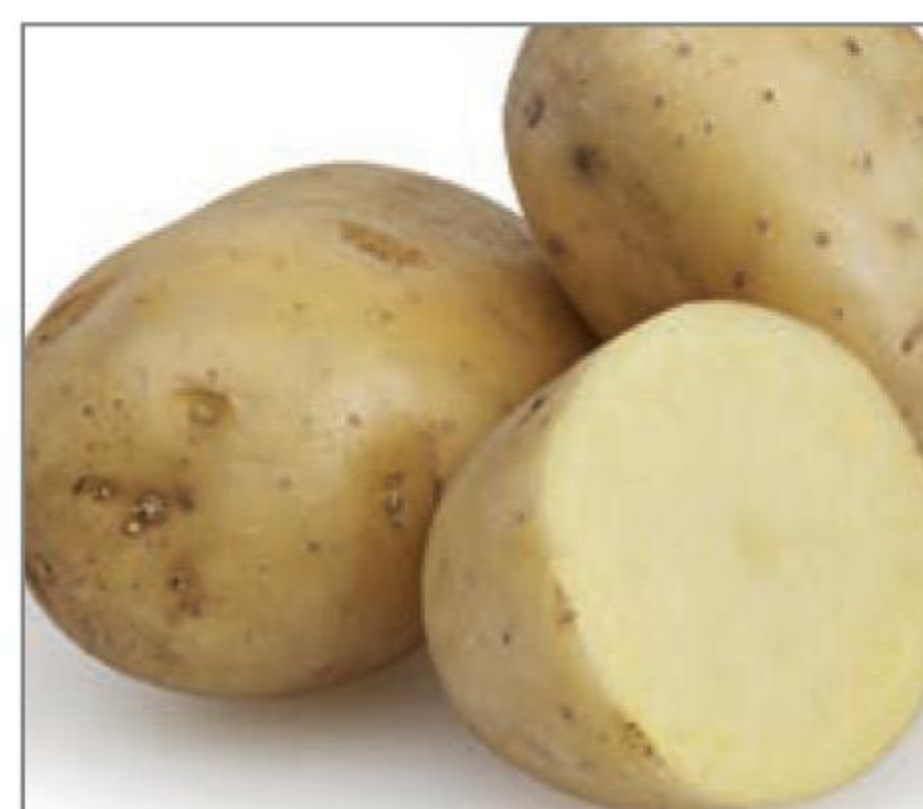

Benefits

Characteristics

Due to the special design of the WANGEN VarioTwin NG's hopper, the proven, low dead-space concept of the Twin series is consistently broadened by further advantages.

When using hopper feed pumps, the media feed may be subjected to severe fluctuations. To balance the fluctuations, the 'coreless' feeder used in WANGEN pumps ensures a large buffer volume during media supply. At the front section of the feeder, excess material is returned by the axial feeder cavity to the rear section and thus balances the feed volume in the case of temporarily low material supply. This ensures a constant even filling during the feed process.

Another advantage of this technology is being able to feed shear-sensitive materials.

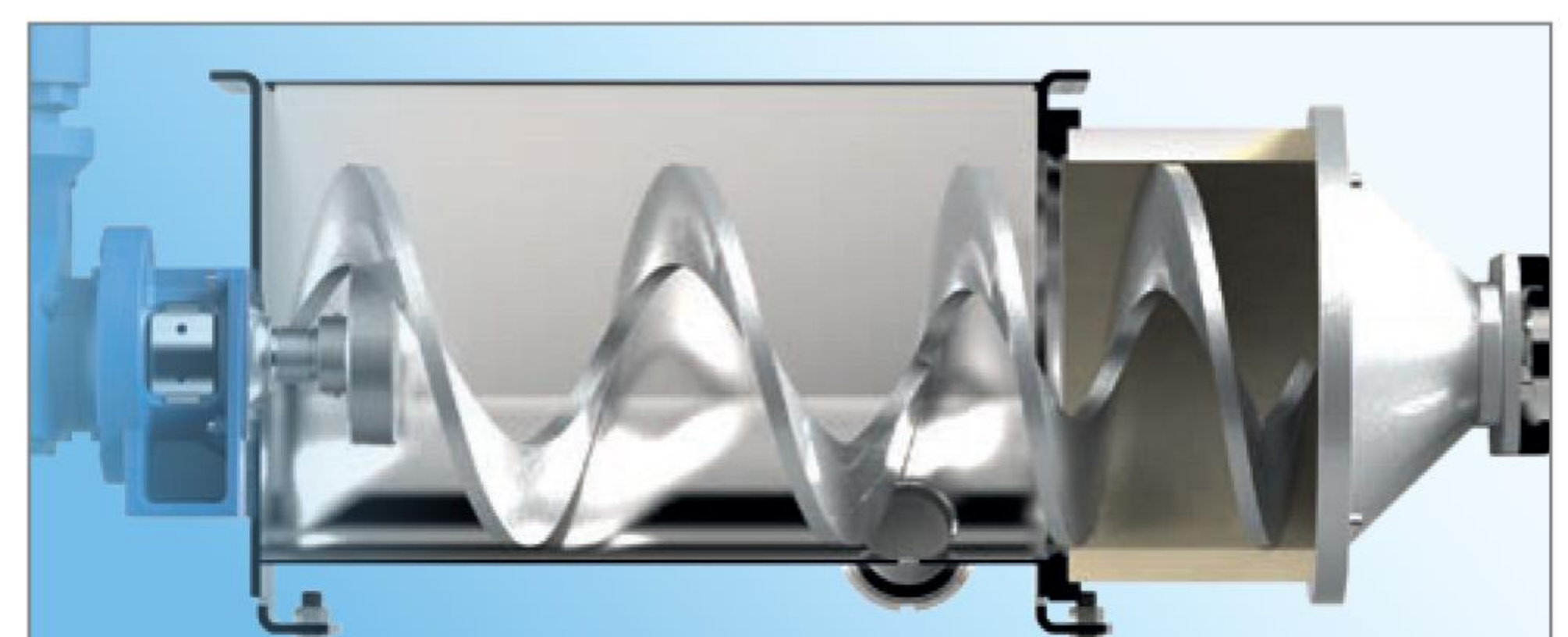
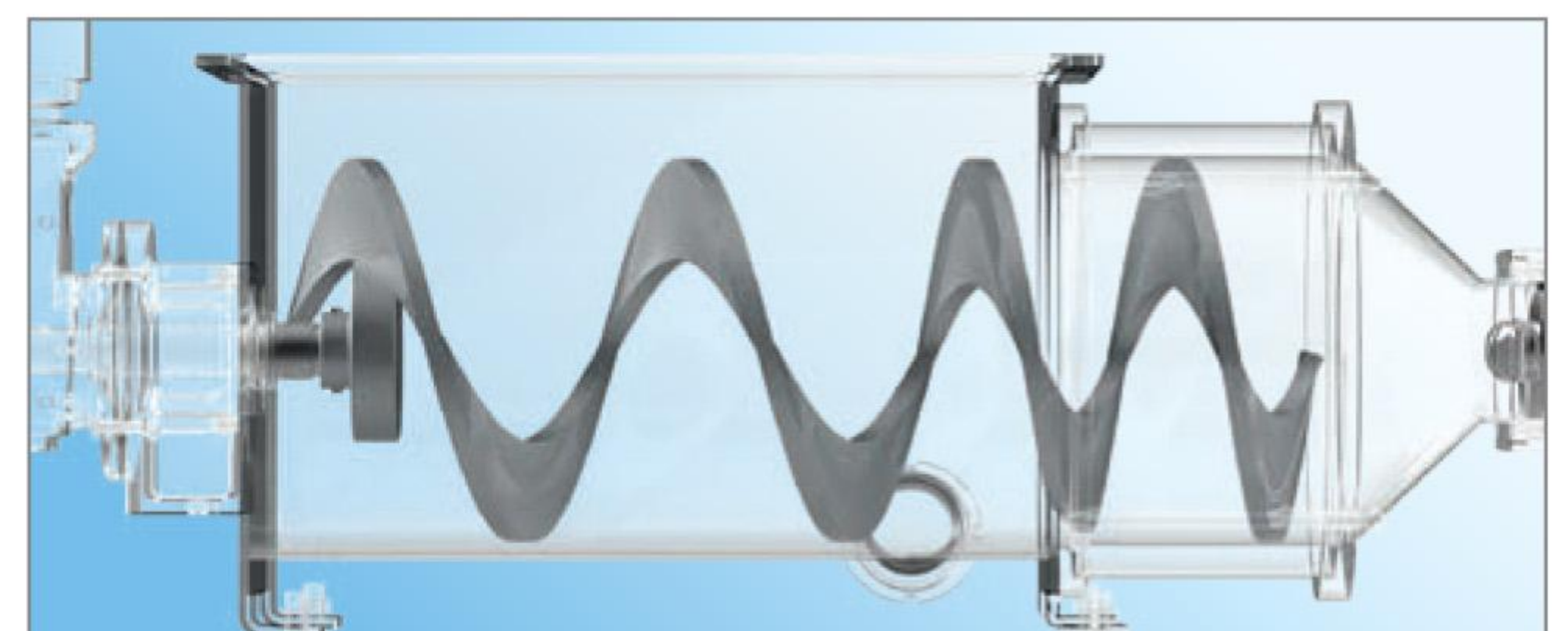

Section of the hopper, side view. Version with spherical feet



WANGEN PUMPEN is certified to:

ISO 9001 (Quality management)

ISO 14001 (Environmental management)

ISO 45001 (Occupational safety and health protection)

All-Pumps Pty.Ltd.

Australia Local: 1300 255 786

Outside Australia: +61 2 8838 1000

Fax: (02) 9630 0369

NSW HEAD OFFICE

100 Silverwater Road Silverwater NSW 2128

PO Box 7138, Silverwater NSW 1811

QLD OFFICE

130 Sandstone Place Parkinson QLD 4115

VIC OFFICE

60 City Road Southbank VIC 3006

CELEBRATING

50

YEARS OF EXPERIENCE

**EXPERIENCE INNOVATIVE
THINKERS AND PRODUCTS**



ALL ABOUT EXPERIENCE

allpumps.com.au

1300 255 786 | sales@allpumps.com.au