

Check and Rotary Valve Pumps

SV-QD Series

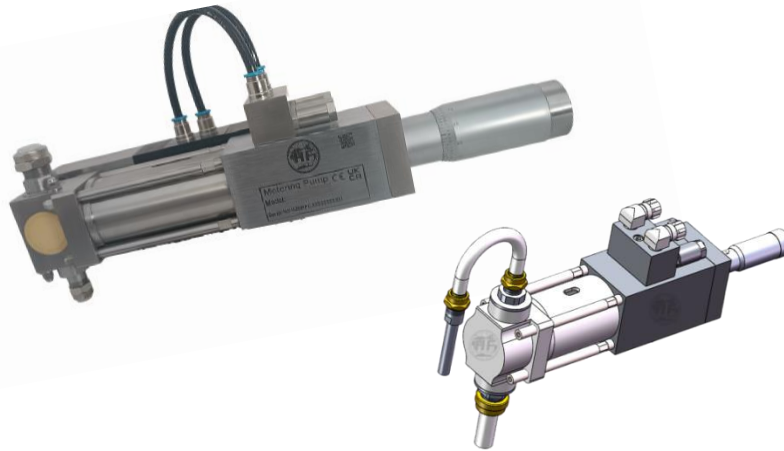

Dispense Volume 0-40ml
Viscosity (Check Valve) Low to Medium (<20,000 cps) Without Particles
Viscosity (Rotary Valve) Medium to High (>20,000 cps) With or Without Particles
Applications
Used in the Food, Pharmaceutical, and Cosmetic Industries, the SV-QD Series is easy to take apart and quickly to clean.



Details

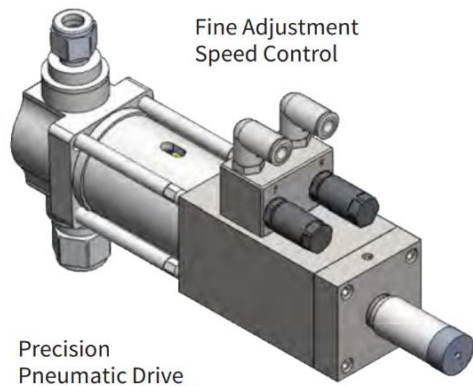

Fine Adjustment
Speed Control

Precision
Pneumatic Drive

Servo Drive Available

Heated Pump options available

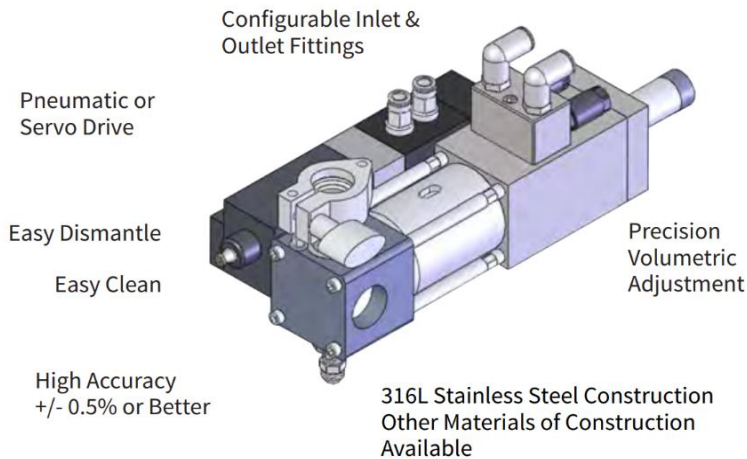

Configurable Inlet &
Outlet Fittings

Pneumatic or
Servo Drive

Easy Dismantle

Easy Clean

High Accuracy
+/- 0.5% or Better

Precision
Volumetric
Adjustment

316L Stainless Steel Construction
Other Materials of Construction
Available

CV & RV Pump Models			Maximum Dispensing	Piston Stroke		Piston Diameter		Cycle Speed	Air Consumption	Weight		
	Pneumatic	Electric	Volume (cc)	mm	inch	mm	inch	(cpm) ^A	scfm (l/min) ^B	lbs (kg) ^C		
SV-QD7C	P	E	7.2	25.4	1	19.05	0.75	0-150 ^A	1.5 (43) ^B	8 (3.6)		
SV-QD10C			9.8			22.20	0.875					
SV-QD14C			14.5			27.00	1.062					
SV-QD20C			20.1	25.4	1	31.80	1.25	0-125 ^A	2.3 (65) ^B			
SV-QD30C			30.0	38.1	1.5							
SV-QD40C			40.0	50.8	2							
SV-QD7R					7.2	25.4	1	19.05	0.75	0-120 ^A	1.9 (454) ^B	9.5 (4.3)
SV-QD10R					9.8			22.20	0.875			
SV-QD14R					14.5			27.00	1.062			
SV-QD20R					20.1	25.4	1	31.80	1.25	0-100 ^A	2.7 (75) ^B	
SV-QD30R					30.0	38.1	1.5					
SV-QD40R					40.0	50.8	2					

^A Depending on the application, the maximum cycle rate will vary ^B Calculated at full stroke at 100cpm, 75 PSI (5 Bar) ^C Pneumatic Drive Only

SMALL VOL. DISP. -- QUICK DISA.



SMALL VOL. DISP. – QUICK DISA.

Fittings		
Type	Size	
	Inlet	Outlet
Sanitary	1/2" - 3/4"	1/2" - 3/4"
Swage	1/8" - 1/2"	1/8" - 3/8"
Tube	1/8" - 1/2"	1/8" - 3/8"
Hose	1/2" - 3/4"	1/2" - 5/8"

O-rings & U-cups	
O-rings	U-cup Seals
Viton	Teflon
EP	UHMW
Silicon	
Buna	
Perfluor (Kalrez®)	

Special sizes and metric available upon request

Check Valve

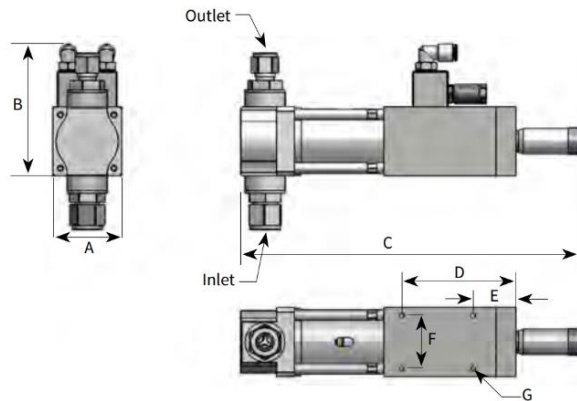

Rotary Valve

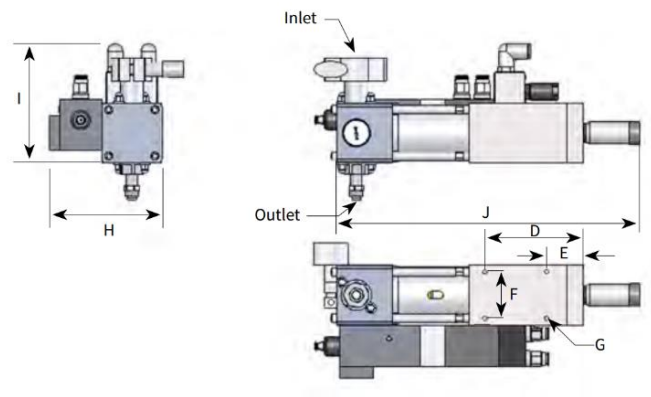

CV & RV Pump Models			Maximum Dispensing Volume (cc)	External Dimensions (Inches[Metric])						
	Pneumatic	Electric		A	B	C	D	E	F	G
SV-QD7C	P	E	7.2	1.94 [49]	3.70 [94]	10.5 [267]	3.2 [81]	1.2 [30]	1.5 [38]	8-32 UNC
SV-QD10C			9.8							
SV-QD14C			14.5							
SV-QD20C			20.1							
SV-QD30C			30.0							
SV-QD40C			40.0							
SV-QD7R			3.65 [93]	3.70 [94]	7.2	10.9 [275]	3.2 [81]	1.2 [30]	1.5 [38]	8-32 UNC
SV-QD10R					9.8					
SV-QD14R					14.5					
SV-QD20R					20.1					
SV-QD30R					30.0					
SV-QD40R					40.0					



HIFE SYSTEMS LTD.
 Aurora Heidenheim Sorocaba Ningbo
 Canada Germany Brazil China

Contact Us:

Asia: sales@hife-battery.com – North America: sales.1@hife-canada.com
 Europe: sales@hife-europe.com – South America: sales@hife-brasil.com